

Model Q46F/82

Auto-Chem Fluoride Monitor

Home Office

Analytical Technology, Inc.
6 Iron Bridge Drive
Collegeville, PA 19426

Ph: 800-959-0299
610-917-0991

Fax: 610-917-0992

Email: sales@analyticaltechnology.com

European Office

ATI (UK) Limited
Unit 1 & 2 Gatehead Business Park
Delph New Road, Delph
Saddleworth OL3 5DE
Ph: +44 (0)1457-873-318

Fax: + 44 (0)1457-874-468

Email: sales@atiuk.com

PRODUCT WARRANTY

Analytical Technology, Inc. (Manufacturer) warrants to the Customer that if any part(s) of the Manufacturer's products proves to be defective in materials or workmanship within the earlier of 18 months of the date of shipment or 12 months of the date of start-up, such defective parts will be repaired or replaced free of charge. Inspection and repairs to products thought to be defective within the warranty period will be completed at the Manufacturer's facilities in Collegeville, PA. Products on which warranty repairs are required shall be shipped freight prepaid to the Manufacturer. The product(s) will be returned freight prepaid and allowed if it is determined by the manufacturer that the part(s) failed due to defective materials or workmanship.

This warranty does not cover consumable items, batteries, or wear items subject to periodic replacement including lamps and fuses.

Gas sensors, except oxygen sensors, are covered by this warranty, but are subject to inspection for evidence of extended exposure to excessive gas concentrations. Should inspection indicate that sensors have been expended rather than failed prematurely, the warranty shall not apply.

The Manufacturer assumes no liability for consequential damages of any kind, and the buyer by acceptance of this equipment will assume all liability for the consequences of its use or misuse by the Customer, his employees, or others. A defect within the meaning of this warranty is any part of any piece of a Manufacturer's product which shall, when such part is capable of being renewed, repaired, or replaced, operate to condemn such piece of equipment.

This warranty is in lieu of all other warranties (including without limiting the generality of the foregoing warranties of merchantability and fitness for a particular purpose), guarantees, obligations or liabilities expressed or implied by the Manufacturer or its representatives and by statute or rule of law.

This warranty is void if the Manufacturer's product(s) has been subject to misuse or abuse, or has not been operated or stored in accordance with instructions, or if the serial number has been removed.

Analytical Technology, Inc. makes no other warranty expressed or implied except as stated above.

Table of Contents

PART 1 - INTRODUCTION	4	5.21 Software Navigation	31
1.1 General.....	4	5.22 Measure Menu [MEASURE].....	34
1.2 Q46F/82 System Specifications	6	5.23 Calibration Menu [CAL].....	35
1.3 Q46F/82 Performance Specifications	7	5.24 Configuration Menu [CONFIG]	36
PART 2 – MECHANICAL INSTALLATION	8	5.25 Control Menu [CONTROL]	39
2.1 General.....	8	5.26 Diagnostics Menu [DIAG].....	44
2.2 Wall Mount Bracket.....	9	PART 6 – CALIBRATION	49
2.3 Panel Mount, AC Powered Monitor	12	6.1 Calibration	49
2.4 Auto-Chem Mounting.....	13	6.11 Automatic Calibration.....	49
2.5 Reagent Bottle Bracket and Pickup Assembly	15	6.12 Manual Calibration	50
2.6 Inlet and Drain Connections	16	6.13 Single Point Manual Calibration.....	51
PART 3 – ELECTRICAL INSTALLATION.....	17	6.2 Temperature Calibration	52
3.1 General.....	17	PART 7 – PID CONTROLLER DETAILS.....	53
3.3 Q46F Sensor Wiring	19	7.1 PID Description	53
3.4 Relay Wiring	20	7.2 PID Algorithm	53
3.2 Auto-Chem Power Panel.....	21	7.3 Classical PID Tuning	56
3.3 Auto-Chem to Q46 Power Interconnect...23		7.4 Manual PID Override Control.....	56
PART 4 – AUTO-CHEM STARTUP.....	24	7.5 Common PID Pitfalls.....	57
4.1 General.....	24	PART 8 – SYSTEM MAINTENANCE.....	58
4.2 Fluoride Buffer Solution	24	8.1 General.....	58
4.3 Reagent Pump Priming	25	8.2 Analyzer Maintenance	58
4.4 Operation	26	8.3 Sensor Maintenance	58
4.5 Sensor Air Purging.....	26	8.4 Sample Pump Tube Replacement	59
4.6 Fluoride Calibration Standards	27	8.5 Reagent Pump Tube Replacement	60
4.61 Mixing Standards	27	PART 9 – TROUBLESHOOTING	61
PART 5 – CONFIGURATION.....	28	9.1 General.....	61
5.1 User Interface.....	28	9.2 External Sources of Problems.....	61
5.11 Keys	29	9.3 Analyzer Tests	62
5.12 Display.....	29	9.4 Display Messages	63
5.2 Software.....	31	SPARE PARTS	64

Table of Figures

FIGURE 1 – TYPICAL FLUORIDE MONITORING SYSTEM	5
FIGURE 2 - Q46F ENCLOSURE DIMENSIONS.....	9
FIGURE 3 - WALL OR PIPE MOUNT BRACKET.....	10
FIGURE 4 - WALL MOUNTING DIAGRAM.....	11
FIGURE 5 - PIPE MOUNTING DIAGRAM.....	11
FIGURE 6 - PANEL MOUNT CUT-OUT.....	12
FIGURE 7 – AUTO-CHEM ENCLOSURE MOUNTING FEET	13
FIGURE 8 – AUTO-CHEM DIMENSIONAL DRAWING.....	14
FIGURE 9 - BOTTLE BRACKET & REAGENT FEED ASSEMBLY.....	15
FIGURE 10 - LINE POWER CONNECTION.....	18
FIGURE 11 - SENSOR CONNECTION	19
FIGURE 12 - RELAY CONTACTS	20
FIGURE 13 – AUTO-CHEM CONNECTION PANEL.....	21
FIGURE 14 - AUTO-CHEM CUSTOMER WIRING.....	22
FIGURE 15 - ANALYZER CONNECTION FROM AUTO-CHEM.....	23
FIGURE 16 – AUTO-CHEM PANEL COMPONENTS	25
FIGURE 17 - USER INTERFACE.....	28
FIGURE 18 - SOFTWARE MAP.....	33
FIGURE 19 - CONTROL RELAY EXAMPLE	42
FIGURE 20 - ALARM RELAY EXAMPLE	43
FIGURE 21 - Q46 ISA PID EQUATION	54
FIGURE 22 – SAMPLE PUMP EXPLODED VIEW	59
FIGURE 23 - Q46 DISPLAY MESSAGES.....	63

Part 1 - Introduction

1.1 General

The Q46F/82 is an on-line monitoring system designed for the continuous measurement of fluoride ion in solution. The full scale operating range of the system may be selected by the user for 0-20.00 PPM, 0-200.0 PPM, or 0-2000 PPM. The analog output signal may be spanned for smaller ranges within the overall operating ranges, if desired. Q46F/82 chemistry modules are designed to operate on sample temperatures from 0-50°C. Because water is flowing through the chemistry module at a low rate, this unit cannot be exposed to temperatures below 0°C.

The basic sensing element used in the monitor is a fluoride ion selective electrode (ISE). This sensor contains a lanthanum fluoride crystal that generates a voltage proportional to the activity of fluoride ion in solution. A silver/silver chloride reference electrode contained in the same sensor body provides the second half of the measurement cell. Because ISE electrodes respond to activity rather than concentration, a small amount of buffer is metered into the sample to provide a constant background condition. With other parameters held constant, fluoride activity and fluoride concentration are closely related. A temperature element in the measuring chamber provides automatic temperature compensation for the system.

Q46F/82 monitors incorporate an automatic calibration feature that maintains high measurement accuracy over long operating periods. The automatic calibration system feeds known fluoride standards into the system at an operator programmable frequency such as every 24 hours, every 3 days, or some other convenient interval. Automatic calibration can be done at any interval between 24 and 999 hours. During calibration, analog output and relays are held at the values measured just before initiation of the calibration sequence. An alarm relay can be used to indicate a calibration failure.

Fluoride monitoring system includes 2 parts, an electronic display unit (panel or wall mount) and a chemistry module. A typical fluoride system installation is shown in Figure 1. The measured fluoride concentration is displayed on a backlit LCD on the front of the instrument. Two 4-20 mA outputs are provided for recording or data logging of fluoride concentration and temperature. Alarm contacts are also standard in the electronic package and may be used either for simple control schemes or for signaling operators of abnormal operating conditions.

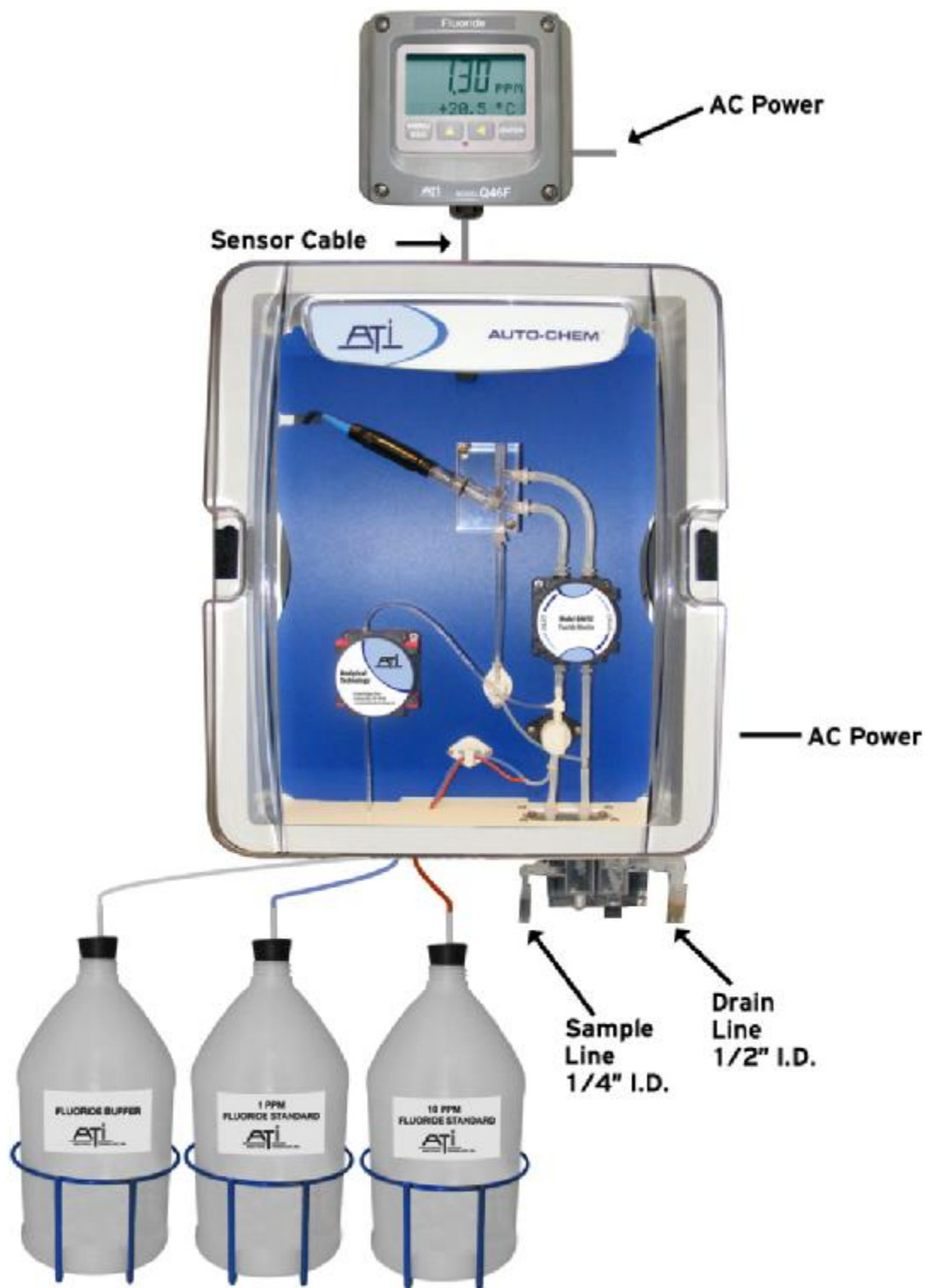

Figure 1 – Typical Fluoride Monitoring System

1.2 Q46F/82 System Specifications

Displayed Parameters	Main input, 0.01 ppm to 2000 ppm dissolved fluoride Sensor mV Sample Temperature Loop current, 4.00 to 20.00 mA Sensor slope & zero offset Model number and software version PID Controller Status
Main Parameter Ranges	Manual selection of one of the following ranges, 0.00 to 20.00 ppm 0.0 to 200.0 ppm 0 to 2000 ppm
Display	0.75" (19.1 mm) high 4-digit main display with sign 12-digit secondary display, 0.3" (7.6 mm) 5x7 dot matrix. Integral LED back-light for visibility in the dark.
Ambient Temperature	Analyzer Service, 5 to 40°C (41 to 104°F) Storage, -5 to 70°C (-22 to 158°F)
Ambient Humidity	0 to 95%, non-condensing.
EMI/RFI Influence	Designed to EN 61326-1
Output Isolation	600 V galvanic isolation
Filter	Adjustable 0-9.9 minutes additional damping to 90% step input
Sensor	Combination F ⁻ / Reference Ion Selective Electrode
Sensor Materials	Glass, Lanthanum Fluoride
Interconnect Cable	10 ft. (6.15 meter) standard
Q46F Power:	100-240 VAC ±10%, 50/60 Hz
Auto-Chem Power:	115 or 230 VAC, 50/60 Hz
Q46F Enclosure:	NEMA 4X, IP66, polycarbonate, stainless steel hardware HWD: 4.9" (124 mm) x 4.9" (124 mm) x 5.5" (139 mm) Flammability rating: UL 94 V-0
Auto-Chem Enclosure:	NEMA 1, IP11, Kydex with Polycarbonate Clear Lid HWD: 4.9" (124 mm) x 4.9" (124 mm) x 5.5" (139 mm) Flammability rating: UL 94 V-0

Mounting Options	Wall mount bracket standard. Panel mount adapter optional for Q46F Only
Relays, Electromechanical:	Three SPDT, 6 amp @ 250 VAC, 5 amp @ 24 VDC contacts. Software selection for setpoint, phase, delay, deadband, hi-lo alarm, and failsafe. A-B indicators on main LCD.
Analog Outputs	Two 4-20 mA outputs. Output one programmable for PPM F ⁻ or PID. Output 2 programmable for PPM or temperature. Maximum load 500 Ohms for each output. Outputs ground isolated and isolated from each other.
Digital Communications (Optional)	Profibus-DP, Modbus-RTU. More versions pending. See Q46 Digital Communications Manual for Specifications.
Sample Flowrate	5 GPH Minimum (315 cc/min) 25 GPH Maximum (1.5 LPM)
Weight	20 lbs. (9 Kg.)

1.3 Q46F/82 Performance Specifications

Accuracy	+/- 0.1 PPM or 0.2% of selected range
Repeatability	+/- 0.05 PPM or 0.1% of selected range
Sensitivity	0.01 PPM
Non-linearity	0.2% of selected range
Warm-up Time	3 seconds to rated performance (electronics only) Sensor requires 1 hour stabilization at start-up
Supply Voltage Effects	± 0.05% span
Instrument Response Time	60 seconds to 90% of step input at lowest damping



Equipment bearing this marking may not be discarded by traditional methods in the European community after August 12 2005 per EU Directive 2002/96/EC. End users must return old equipment to the manufacturer for proper disposal.

Part 2 – Mechanical Installation

2.1 General

Mechanical installation of a Q46F/82 fluoride system involves mounting of the Q46F electronic assembly, mounting of the Auto-Chem chemistry module, and mounting of the reagent bottle brackets.

Proper planning of the installation will benefit operation and maintenance of the system. Here are a few considerations

1. Locate the Q46F electronics where personnel can easily access the front panel control keys. Calibration of the system requires access to these controls.
2. Locate the chemistry module high enough above the floor so that servicing of the pumps is not difficult. Pump tubing must be replaced every 6 months so access to the chemistry system is required.
3. Do not mount the reagent bottle closer than about 18" from the bottom of the chemistry module. Mounting too close will make removal of the bottle difficult.
4. Water sample and drain lines connect to an inlet overflow assembly at the bottom of the chemistry module. Locate the chemistry module so that the drain line is short and can flow freely.

The Q46F monitor is wall mounted using a PVC plate supplied with the unit. The bracket kit contains 4 screws for attaching the plate to the back of the enclosure. A paper template is supplied to ease of locating anchors in the wall.

The Auto-Chem chemistry module is supplied with 4 stainless steel mounting feet and 8 attachment screws (10-32 x 1/4" long). Inserts in the back of the enclosure provide for attachment of the mounting feet.

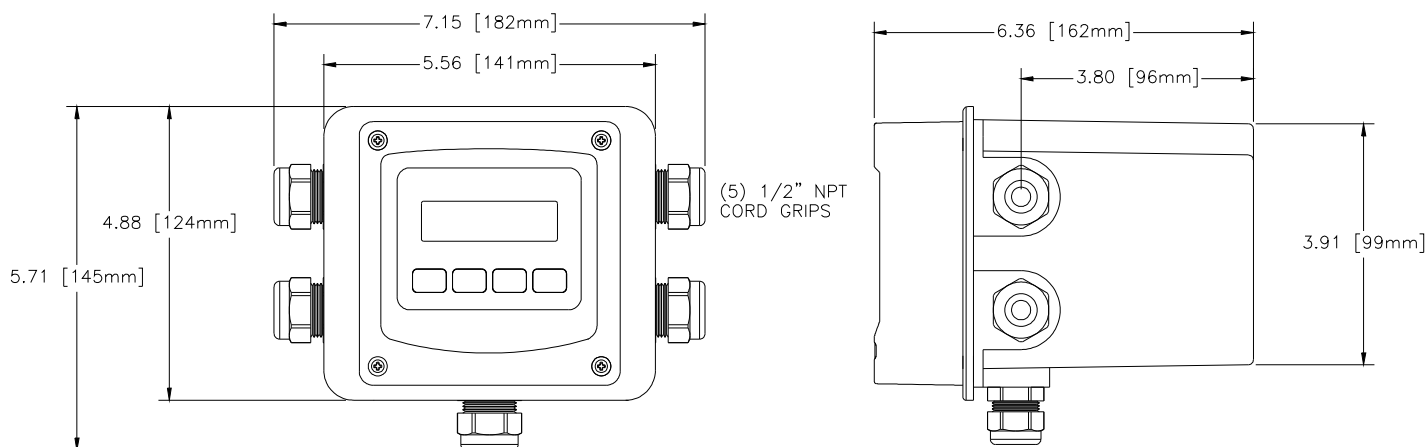

Figure 2 - Q46F Enclosure Dimensions

2.2 Wall Mount Bracket

A PVC mounting bracket with attachment screws is supplied with each transmitter (see Figure 3 for dimensions). The multi-purpose bracket is attached to the rear of the enclosure using the four flat head screws. The instrument is then attached to the wall using the four outer mounting holes in the bracket. These holes are slotted to accommodate two sizes of u-bolt that may be used to pipe mount the unit. Slots will accommodate u-bolts designed for 1½" or 2" pipe. The actual center to center dimensions for the u-bolts are shown in the drawing. Note that these slots are for u-bolts with ¼-20 threads. The 1½" pipe u-bolt (2" I.D. clearance) is available from ATI in type 304 stainless steel under part number 47-0005

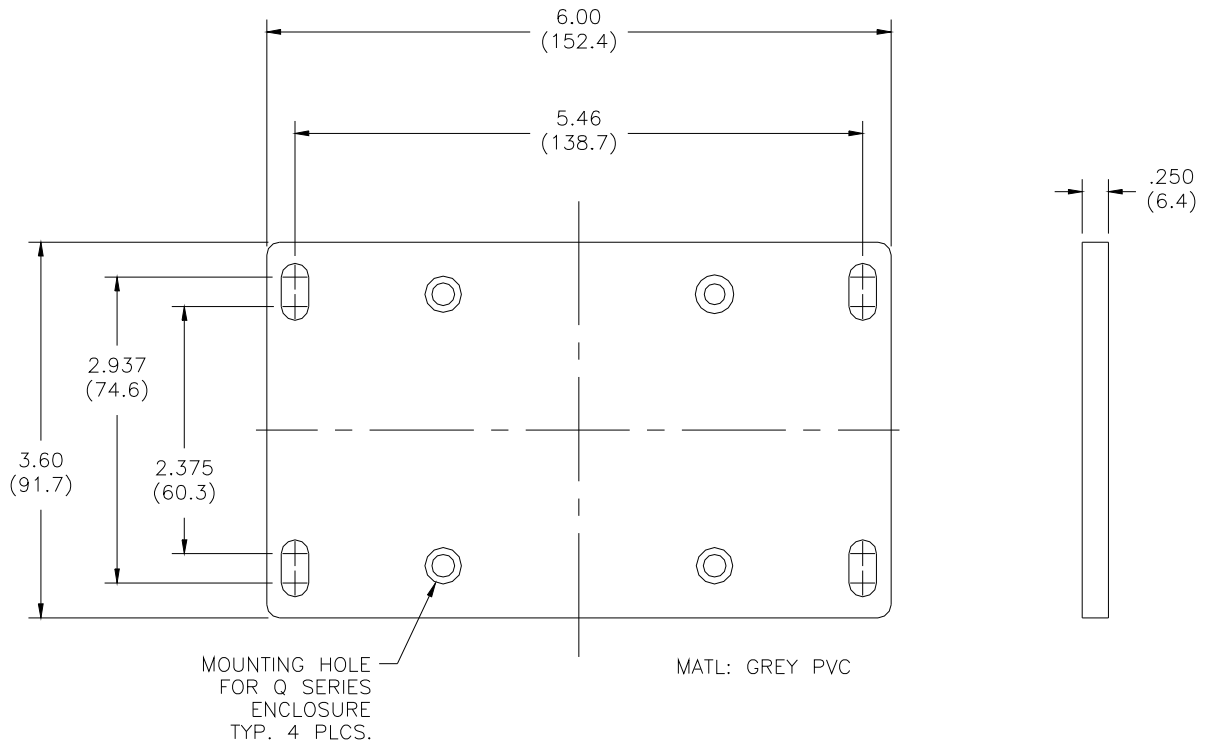

Figure 3 - Wall or Pipe mount Bracket

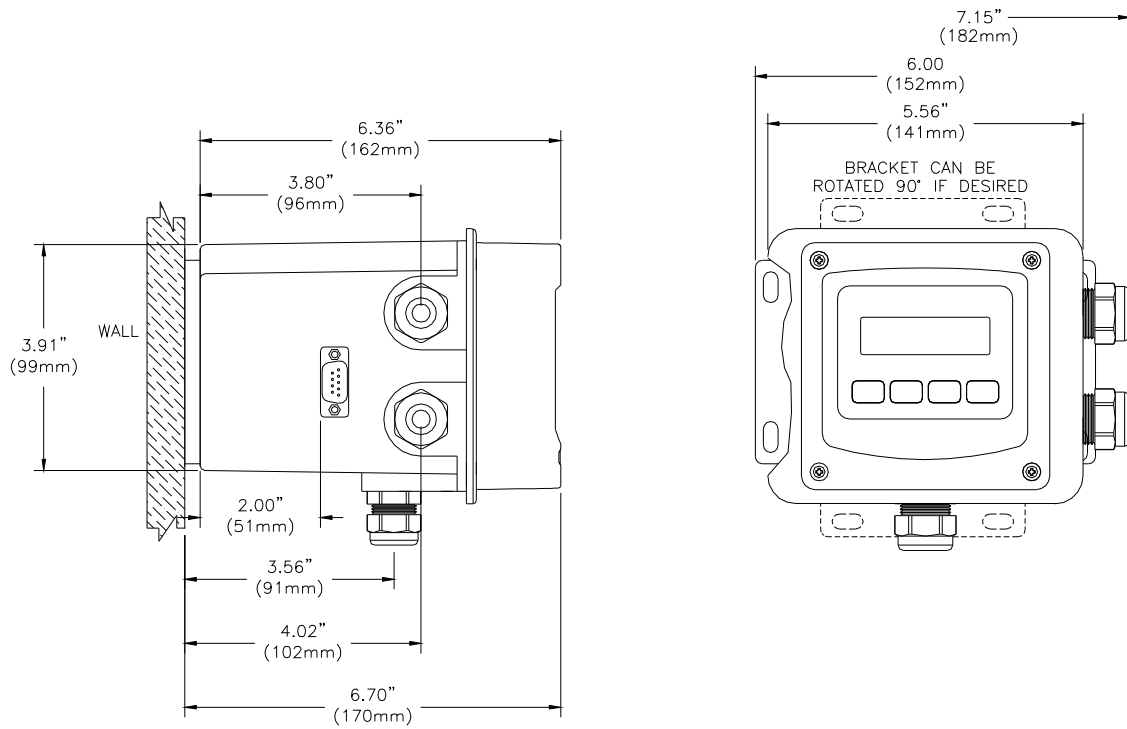

Figure 4 - Wall Mounting Diagram

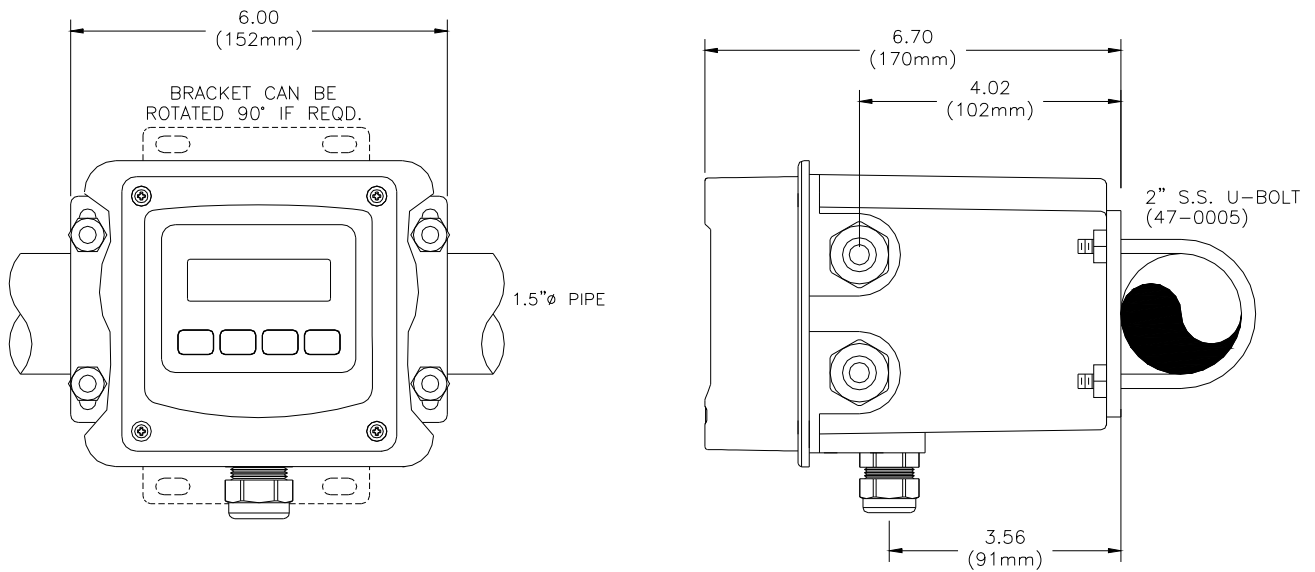

Figure 5 - Pipe Mounting Diagram

2.3 Panel Mount, AC Powered Monitor

Panel mounting of the Q46F monitor uses the panel mounting flange molded into the rear section of the enclosure. Figure 6 provides dimensions for the panel cutout required for mounting.

The panel bracket kit must be ordered separately (part number 05-0094). This kit contains a metal retainer bracket that attaches to the rear of the enclosure, 4 screws for attachment of this bracket, and a sealing gasket to insure that the panel mounted monitor provides a water tight seal when mounted to a panel.

The sealing gasket must first be attached to the enclosure. The gasket contains an adhesive on one side so that it remains in place on the enclosure. Remove the protective paper from the adhesive side of the gasket and slide the gasket over the back of the enclosure so that the adhesive side lines up with the back of the enclosure flange. Once in place, mount the monitor in the panel.

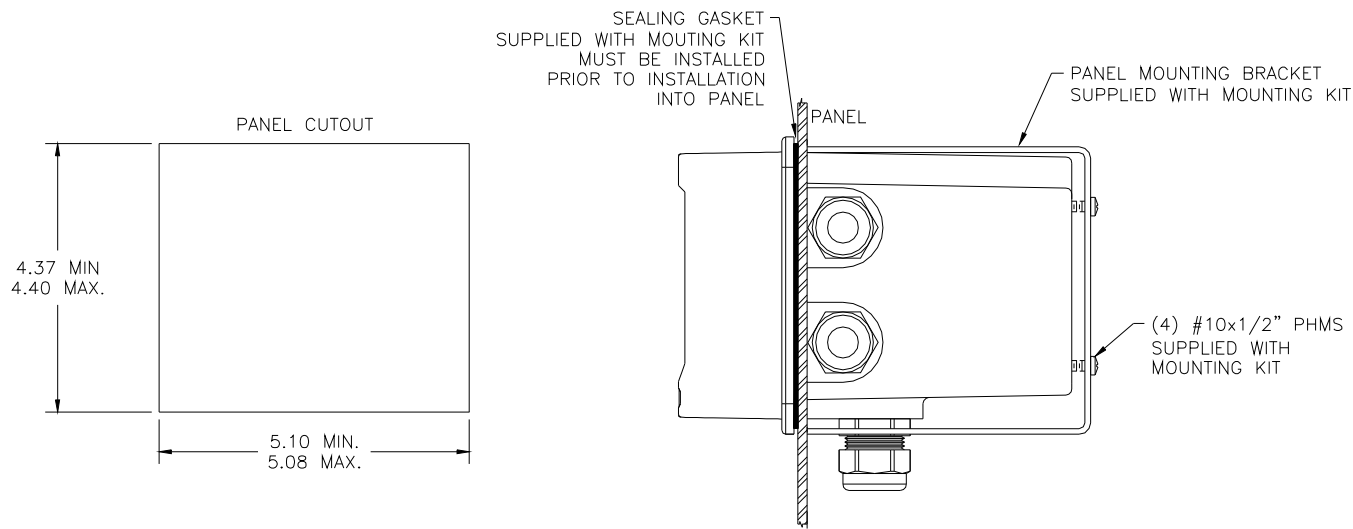

Figure 6 - Panel Mount Cut-Out

2.4 Auto-Chem Mounting

The chemistry module should be mounted on a wall or flat plate. A template is provided for marking the location of mounting screws. The stainless steel mounting feet must first be screwed to the back of the enclosure using the screws supplied.

Tape the mounting template to the wall and mark the 4 screw locations. Mount any wall anchors first and then screw in the two bottom mounting screws about half way. Place the two bottom mounting feet of the enclosure on to the screws and tilt the enclosure into place. Install the two top screws to secure the enclosure and then tighten the bottom screws.



Figure 7 – Auto-Chem Enclosure Mounting Feet

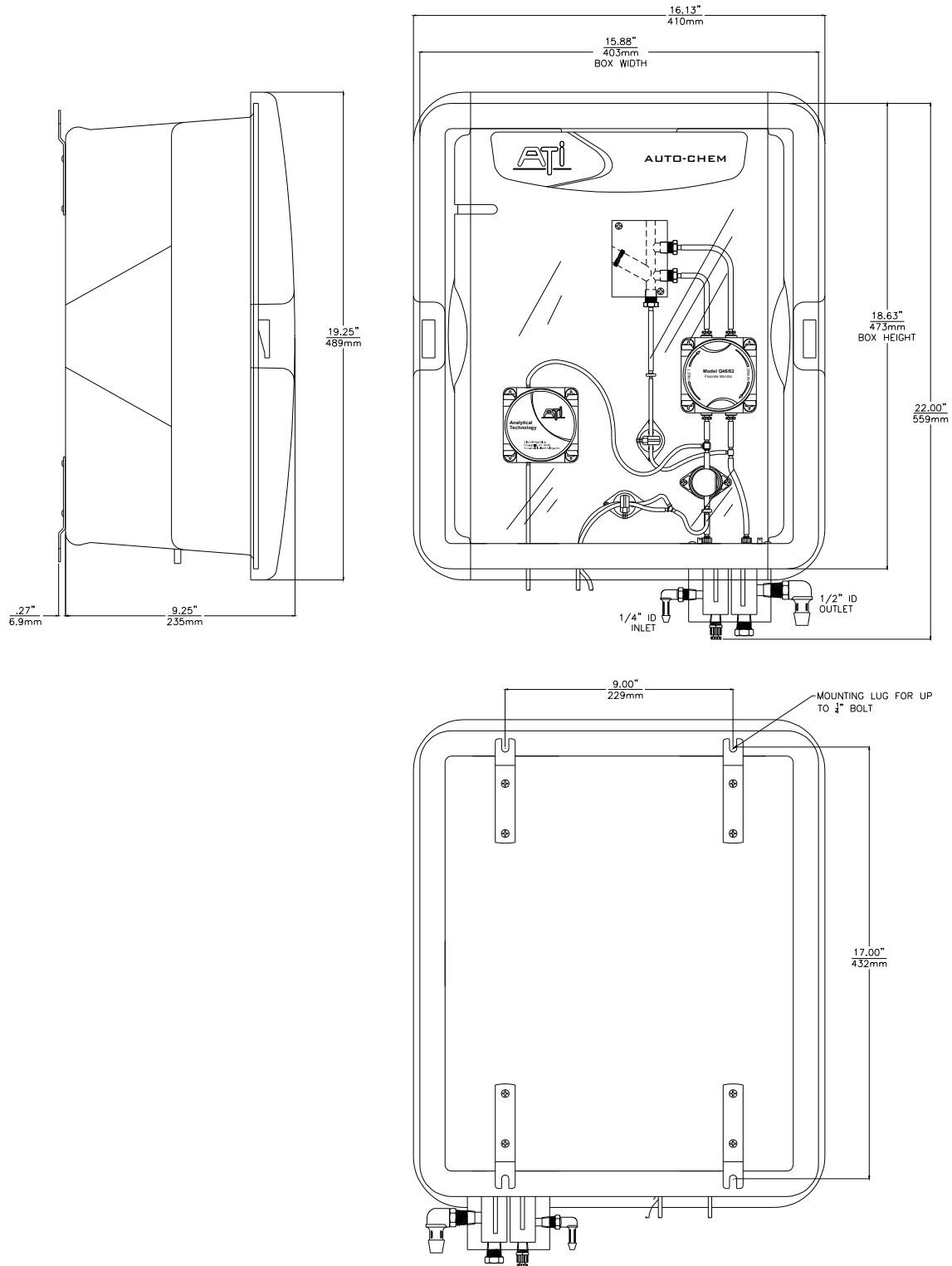

Figure 8 – Auto-Chem Dimensional Drawing

2.5 Reagent Bottle Bracket and Pickup Assembly

The Auto-Chem system requires approximately 1 gallon of reagent every 25 days. A one gallon bottle holder is supplied and mounts to the wall. It is sufficient to mount the bracket using only the upper two mounting holes. A standards pick-up assembly (03-0450) is supplied that fits into the mouth of the bottle. Attach the tubing connector to the tubing after you have slid tubing from chemistry system through the ceramic tube coming through bottle stopper. This will keep the tubing from floating to the top of the liquid.

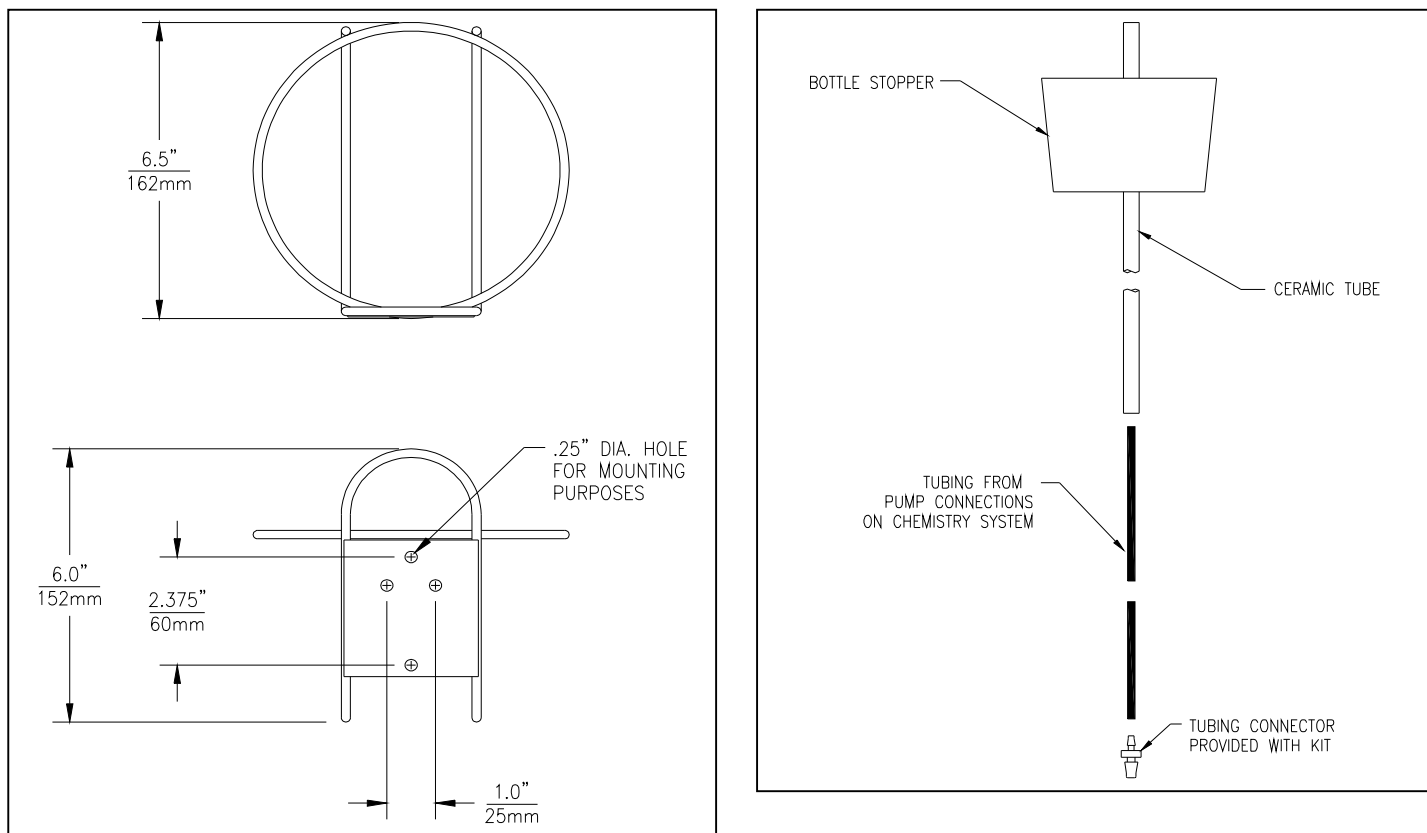

Figure 9 - Bottle Bracket & Reagent Feed Assembly

2.6 Inlet and Drain Connections

Note: To avoid shipping damage, the inlet assembly is shipped separately and must be installed on the bottom of the chemistry module after the enclosure has been mounted to the wall. The inlet assembly is supplied with 4 mounting screws for attachment to the enclosure. The photo below shows the inlet assembly attached to the enclosure.

The water sample containing dissolved fluoride must be connected to the inlet overflow assembly mounted on the bottom of the chemistry module. For convenience, a 10 ft. piece of ¼" I.D. PVC tubing is supplied. This tubing mates with the inlet hose barb located on the left side of the inlet assembly.

The drain connection is a ½" I.D. hose barb on the right side of the overflow assembly. A 5 ft. length of PVC drain tubing is also supplied. The drain should be a free flowing gravity drain. No backpressure is allowed on the drain line.

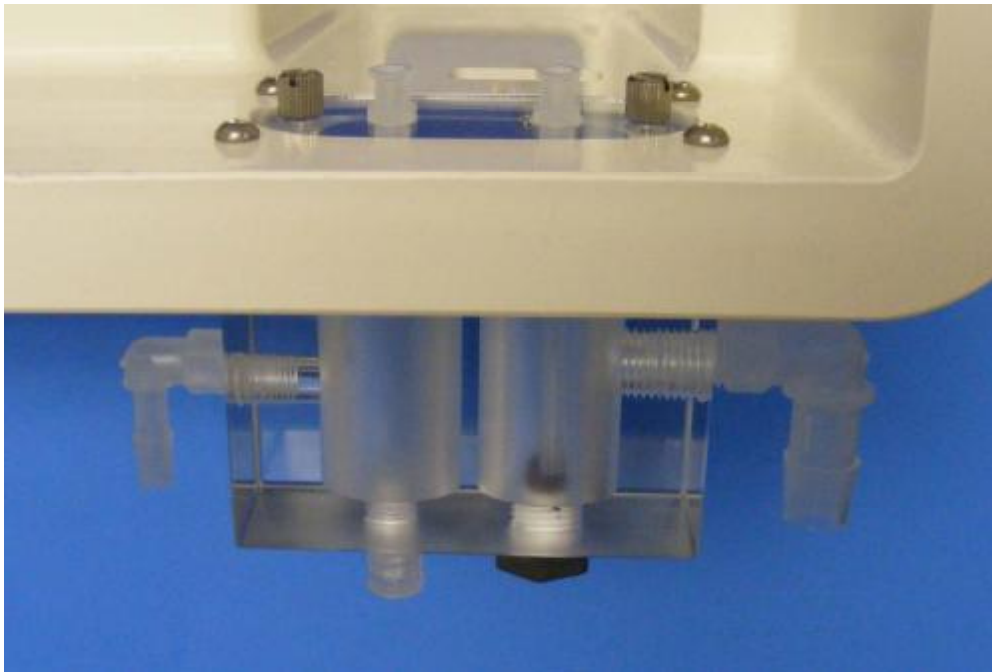

Part 3 – Electrical Installation

3.1 General



The Q46 electronics contains a universal power supply operating on voltages between 90 and 265 VAC, 50/60 cycle. Auto-Chem Chemistry modules are not universal and must be ordered for operation from EITHER 115 VAC or 230 VAC. Please verify the type of unit before connecting any power. The Auto-Chem assembly contains two DIN rail mounted power supplies, one of which is AC power dependent. The 24 VAC supply located next to the AC power input terminals is the power supply that must be compatible with the installation site. If there is any question, remove the power supply from the DIN rail and check the label on the bottom of the supply. **Connection of 230 VAC power to a 115 VAC unit will result in damage to the power supply assembly.**

Important Notes:

1. Use wiring practices that conform to all national, state and local electrical codes. For proper safety as well as stable measuring performance, it is important that the earth ground connection be made to a solid ground point from terminal 12 (Figure 10).
2. Do NOT run sensor cables or instrument 4-20 mA output wiring in the same conduit that contains AC power wiring. AC power wiring should be run in a dedicated conduit to prevent electrical noise from coupling with the instrumentation signals.

Q46 electronic units are supplied with five ½” NPT ports, two on each side and one on the bottom. Red plugs are provided for each port. Five cord grips are supplied separately for use during installation. A cord grip should be installed in the bottom port for sealing the sensor cable connection to the Auto-Chem unit. AC power should enter through the lower right hand port as the AC terminals are closest to this entry.

WARNING

Disconnect line power voltage BEFORE connecting line power wires to Terminal TB7 of the power supply. The power supply accepts only standard three-wire single phase power. The power supply is configured for 100-240 VAC ±10% operation.. Do NOT connect voltages other than the labeled requirement to the input.

Connect HOT, NEUTRAL, and GROUND to the matching designations on terminal strip **TB7**.

The analog outputs from the system are present at terminals TB1. The loop-load limitation in this configuration is 500 Ohms maximum for each output. Also note that these two outputs are completely isolated from each other to insure that ground loops do not result from the connection of both outputs to the same device such as a PLC or DCS.

A ribbon cable connects the power supply assembly with the microprocessor assembly located in the front section of the enclosure. This cable can be disconnected from the front section during installation to facilitate wiring. The ribbon cable has a marking stripe on one edge that is used to indicate proper orientation.

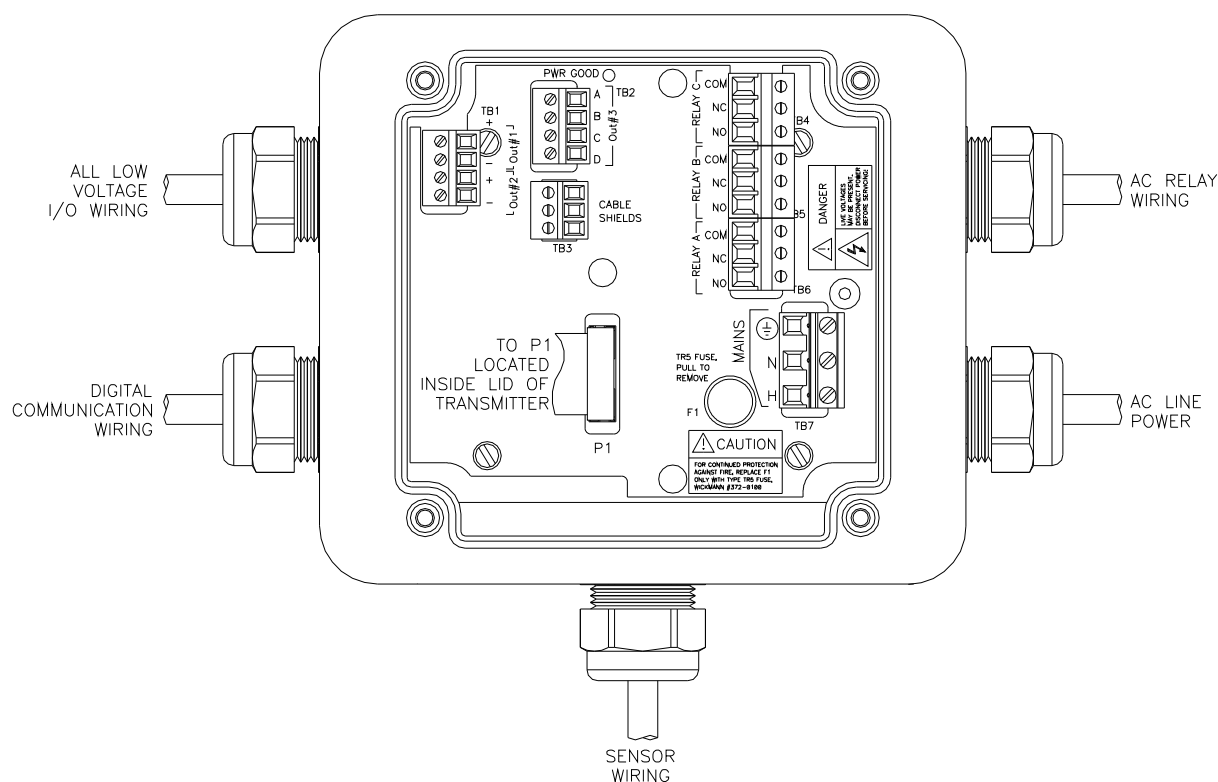

Figure 10 - Line Power Connection

The power strip, **TB5**, allows up to 12 AWG wire. A wire gauge of 16 AWG is recommended to allow for an easy pass-through into the M16 ports when wiring.

3.3 Q46F Sensor Wiring

The interconnection between the Auto-Chem module and the Q46F electronics is a 9-conductor shielded cable. The chemistry module contains an amplifier module that converts the sensor signal to a low impedance signal that is less susceptible to noise or signal loss problems. Five of the nine conductors are used for the output of the amplifier and the other four are used to control the automatic calibration system. A 10 ft. length of 9-conductor cable is supplied but this cable may be shortened if desired. Removing excess cable makes for a cleaner installation and reduces the potential for RFI pickup in the interconnecting cable. **NOTE: IF JUMPER WIRE IS PRESENT BETWEEN POSITIONS 4 AND 8 PLEASE REMOVE.**

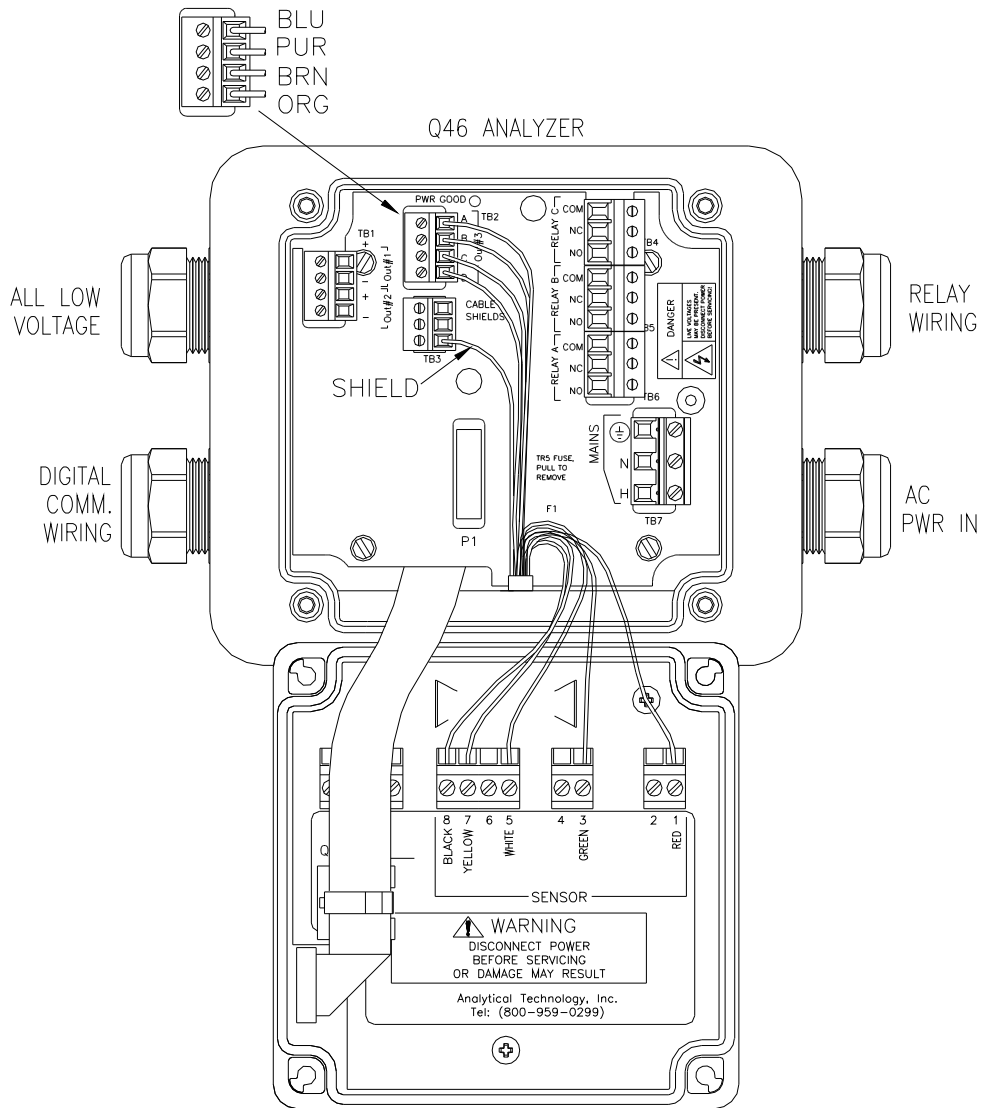

Figure 11 - Sensor and Control Connection

The standard 10 ft. cable supplied with the system is already terminated inside the Auto-Chem unit and is stripped and ready for wiring on the end to be connected to the Q46F. Cord-grips used for sealing the cable should be snugly tightened after electrical connections have been made to prevent moisture incursion. When cutting multi conductor cable used for this system, be sure to strip back the cable jacket by 4 inches to insure individual conductors can be routed properly inside the Q46F enclosure.

3.4 Relay Wiring

Three SPDT relays are provided on the power supply board. None of the relay contacts are powered. The user must supply the proper power to the contacts. For applications that require the same switched operating voltage as the Q46 (115 or 230 V), power may be jumpered from the power input terminals at **TB7**. Relay wiring is connected at **TB4, TB5, and TB6** as shown below. Note that the relay contact markings are shown in the NORMAL mode. Programming a relay for “Failsafe” operation reverses the NO and NC positions in this diagram (Figure 12).

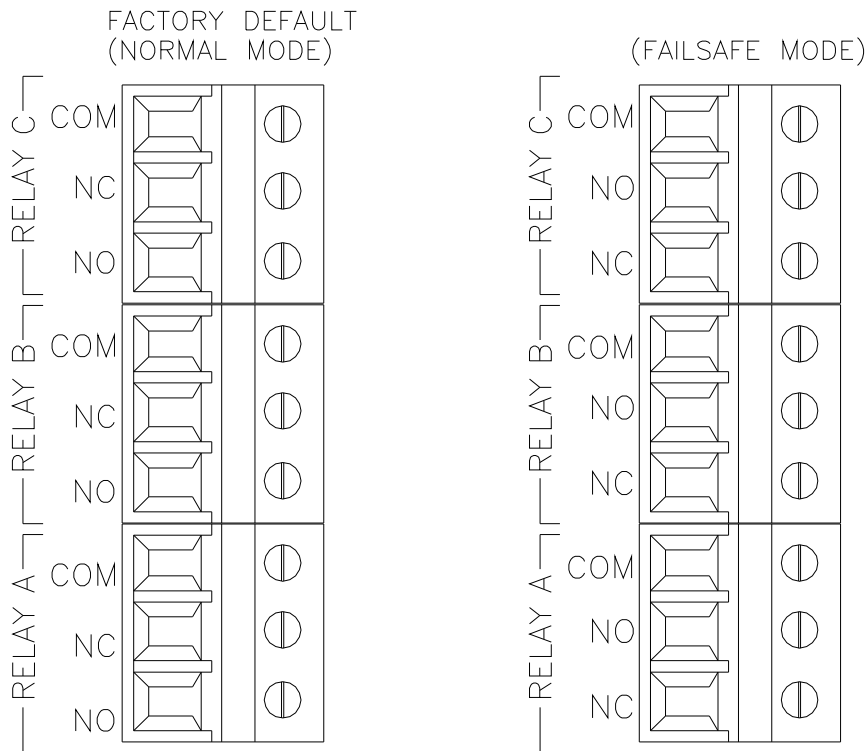

Figure 12 - Relay Contacts

3.2 Auto-Chem Power Panel

The chemistry module contains terminals and power supplies on a DIN rail located behind the front panel. During installation, it is often convenient to completely remove the front panel, allowing access to terminals inside. To remove the front panel, first disconnect the inlet and outlet luer fittings from the inlet overflow chamber. Locate the blue and red tubes for auto-calibration and slide them out of the solenoid pinch valve. Then disconnect the common outlet tube where the red and blue tubes come together so that these tubes are no longer connected to the front panel. Finally, open the latch at the top of the panel and allow the panel to hinge forward. A retaining strap will stop the panel from moving too far.

The two pumps are plugged into the 24 VAC power supply on the right. The three solenoid valves are wired to two location, a terminal strip for one lead and the 12 VDC power supply for the second lead. Pump motors and all 3 solenoid valves are disconnected by unplugging the moxex connectors. The RTD temperature element wires have a moxex connector as well so that it can be disconnected when removing the front panel.

Once everything is disconnected, open the Velcro on the retaining strap and slide the strap through the slots on the front panel. At this point, the entire front panel can be removed from the enclosure. Below is a photo of the interior showing power supplies and terminals.

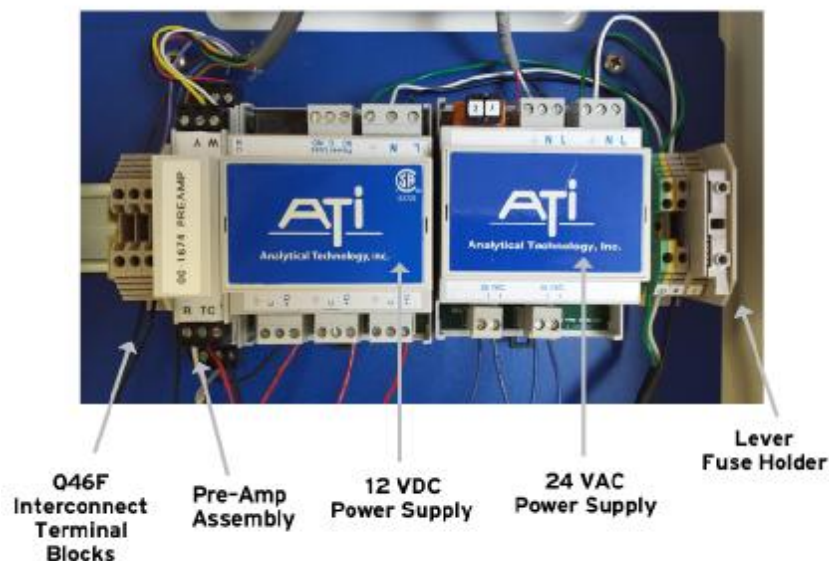

Figure 13 – Auto-Chem Connection Panel

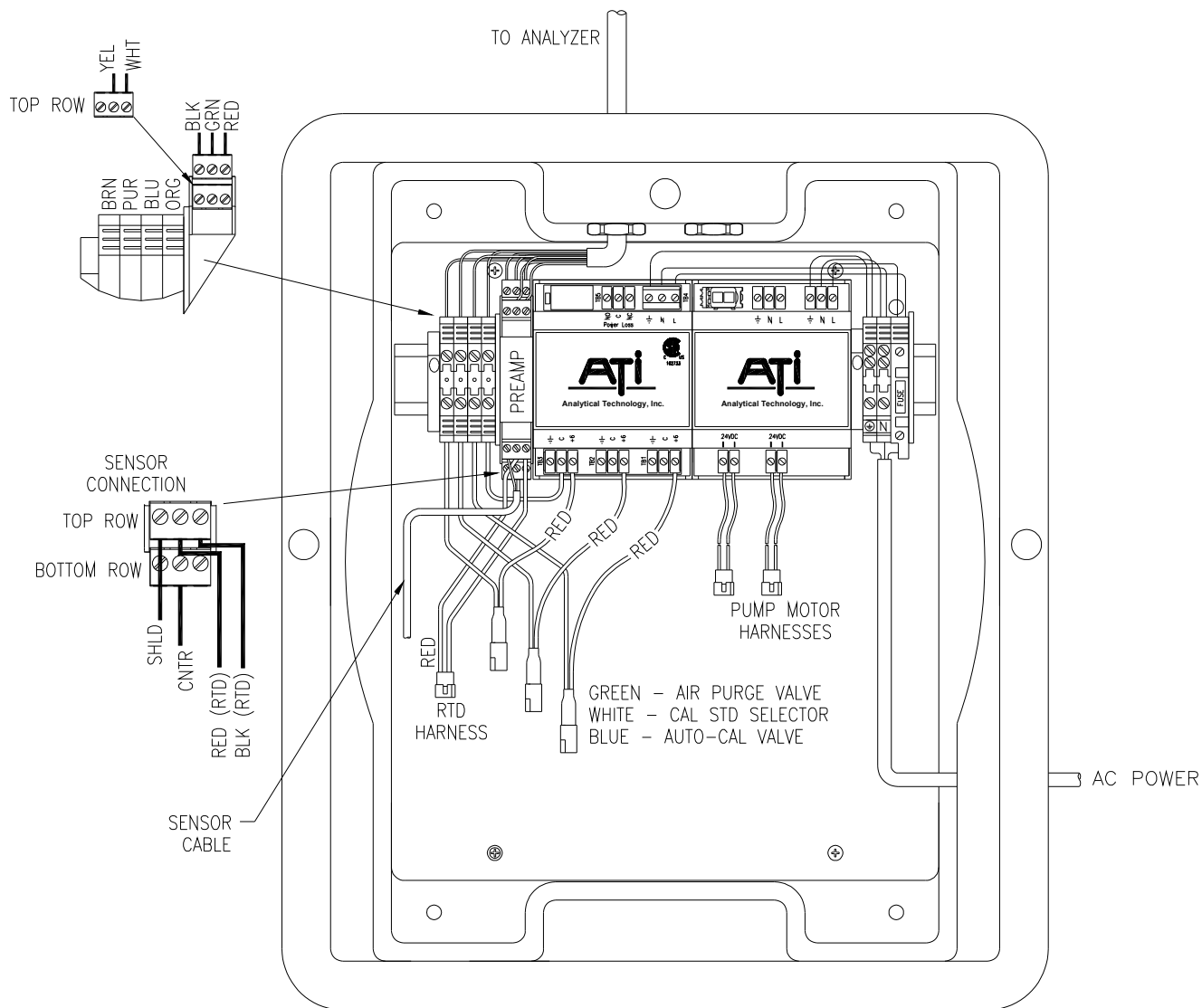

Figure 14 - Auto-Chem Customer Wiring

3.3 Auto-Chem to Q46 Power Interconnect

In some installations, it may be convenient to provide power to the Q46F monitor through terminals provided on the 24 VAC power supply. The advantage of this arrangement is that the lever fuse in the Auto-Chem module can be used to turn power on and off in both the chemistry unit and the monitor.

Refer to Figure below. On the top side of the 24 VAC power supply you will see a 3-point terminal block that is unused. It is just left of the AC power connections that are factory wired. Connection of a 3-conductor AC power cord from these terminals up to TB7 of the Q46F electronics will power the Q46F through the chemistry module.

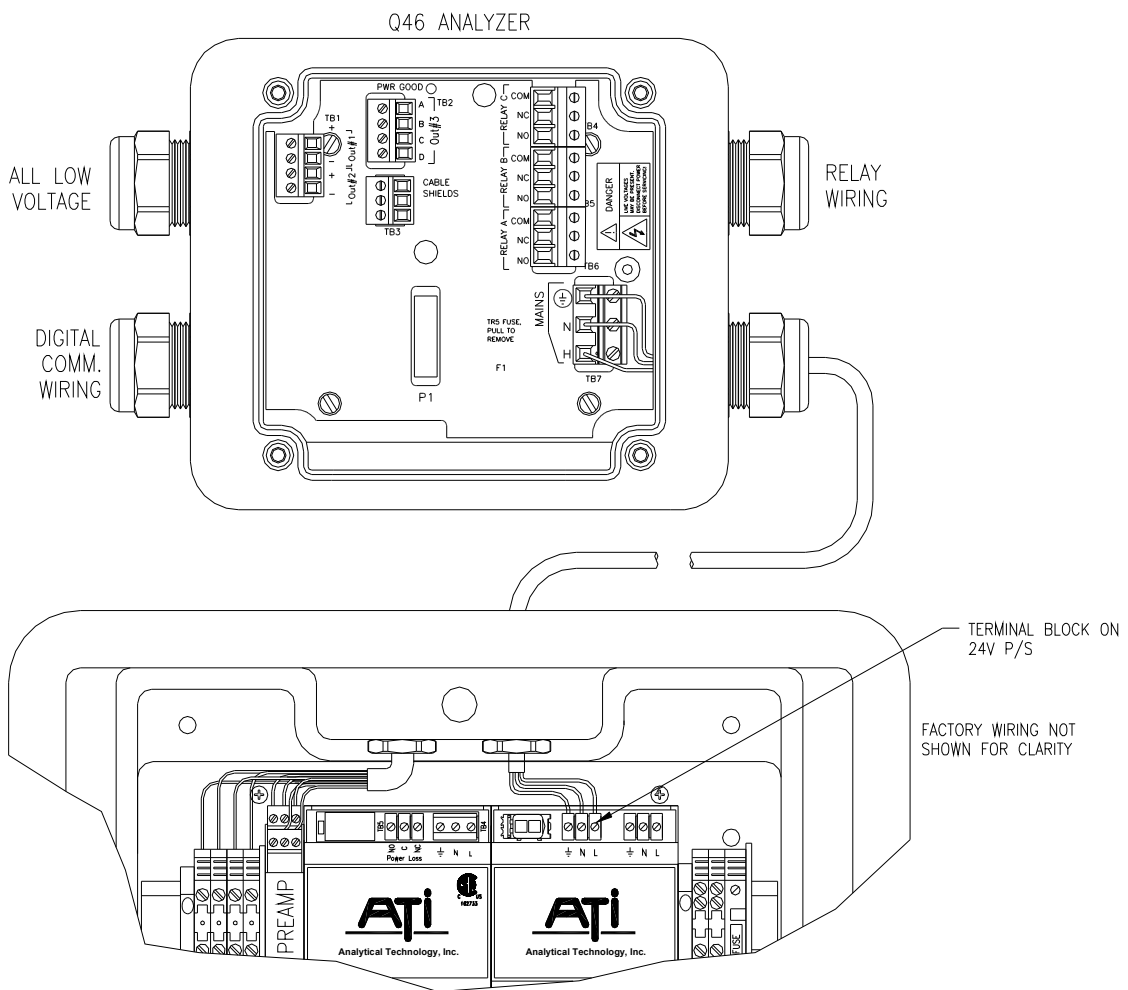

Figure 15 - Analyzer Connection from Autochem

Part 4 – Auto-Chem Startup

4.1 General

Prior to operating the chemistry module, connect inlet sample and drain tubing to the hose barbs provided on inlet overflow assembly. Remove the clear cover from the chemistry module and check the inlet and outlet tube connections on the inside cover of the overflow assembly. Also, check to be sure that the reagent pickup tube is connected to the inlet fitting of the reagent pump.

Before applying power to the chemistry module, the combination fluoride/reference electrode must be installed. The electrode is shipped dry in the electrode box and should be stored in this condition until it is time to commission the monitor. The reference filling solution is supplied in a separate bottle along with a plastic dropper used to fill the electrode. Near the top of the electrode is a black plastic sleeve that covers the fill port. Pull the sleeve down so the fill hole is accessible and fill the reference chamber with the solution using the plastic dropper. Push the sleeve back up over the fill hole and the sensor is ready for use.

The fluoride electrode slides into the flow block on the front of the Auto-Chem module. The electrode cable, which is pre-installed, connects the sensor directly to the monitor. This cable screws onto the back of the electrode. The fluoride electrode outputs a high impedance signal so the cable should not be spliced.

4.2 Fluoride Buffer Solution

The buffer solution used in the Q46F/82 Fluoride Monitor adjusts the sample pH to about 5.3 and increases the ionic strength of the sample to provide a stable fluoride measurement. The dry buffer can be purchased from ATI or it can be purchased in bulk from a chemical supply house by the end user.

The buffer solution consists of sodium acetate and white vinegar. If you purchased the dry buffer from ATI, simply fill the gallon container with white vinegar, cap the bottle, and invert several times to mix. If you are providing both chemicals, place 1000 grams of sodium acetate (Fisher Scientific #S207-10) in the gallon buffer container. Fill the container with white vinegar, cap the bottle, and invert several times to mix. The buffer will have to sit for approximately 1 hour prior to use to allow all of the sodium acetate to dissolve.

4.3 Reagent Pump Priming

Buffer is pulled from the gallon container by a peristaltic pump in the Auto-Chem. The pump rate for chemical feed is about 0.1 cc/min. It can take up to 20 minutes for buffer to reach the sample injection point when power is first applied.

If desired, the reagent feed tube can be manually filled to reduce the waiting time. A 5 cc syringe with plastic tip is supplied for this purpose. To fill the feed tube, release the pressure on the reagent pump tube by loosening the clamp plate on the left side of the pump. Then disconnect the 1/16" I.D. tube from the injection tee below the sample pump. Insert the tip of the syringe into the tube and use the syringe to draw reagent from the bottle into the syringe. When reagent has reached the syringe, replace the pressure plate on the reagent pump. Once the pressure plate is properly seated, disconnect the syringe and connect the tubing to the injection tee. Discard any buffer in the syringe and rinse.

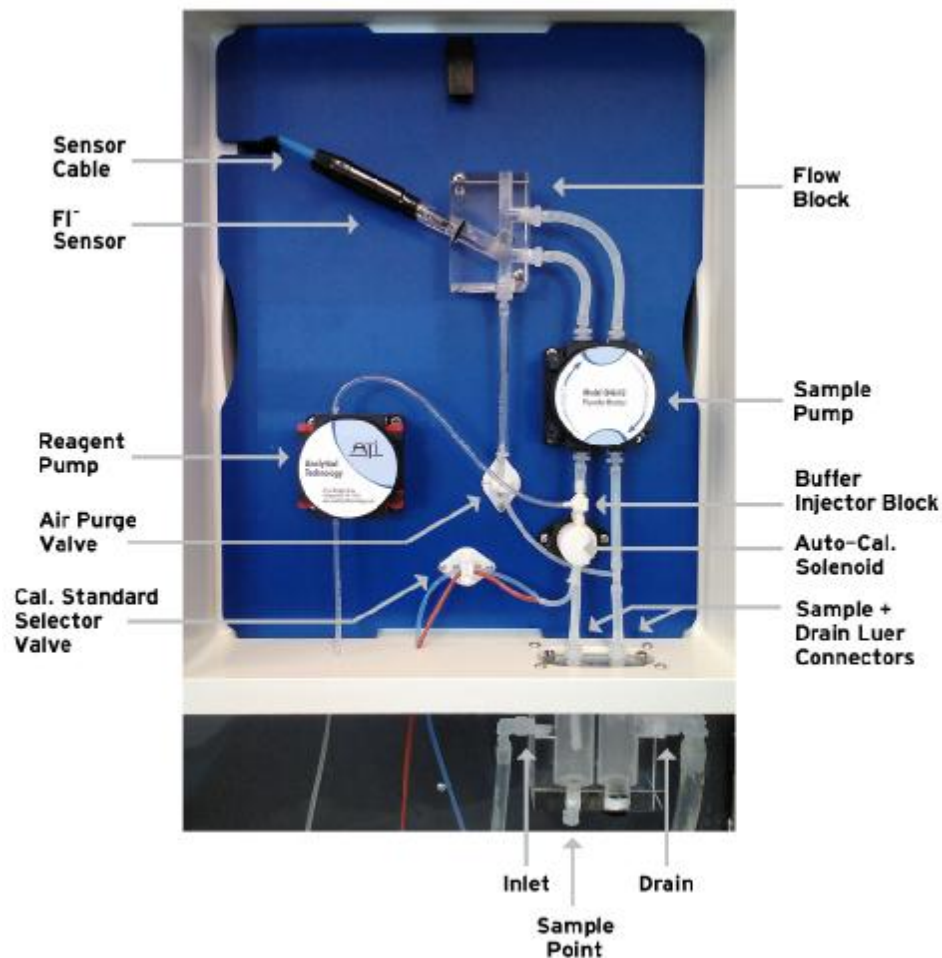

Figure 16 – Auto-Chem Panel Components

4.4 Operation

As noted in the “Electrical Installation” section, the chemistry module contains a lever fuse holder that can be used to turn the chemistry system on and off. Once the steps outlined earlier in this section are complete and power has been connected to the proper terminals, simply close the lever fuse to activate the chemistry module.

Once power is applied, the two peristaltic pumps will start to turn. If the power to the Q46F comes on at the same time, you might hear the large solenoid valve under the sample pump cycle once.

Assuming that sample is flowing to the overflow assembly, sample will reach the fluoride sensor block in just a few seconds. If the reagent feed has been manually primed, the system will begin to function almost immediately. It is best to allow the system to run undisturbed for 1 hour after initial startup. Do not be concerned if you see either high or low fluoride values at this point. Remember that the system has not yet been calibration and calculated concentrations will be based on default settings from the factory that may, or may not, be close to this particular sensor.

4.5 Sensor Air Purging

During analyzer operation, air bubbles can slowly accumulate on the face of the fluoride sensor. This is usually caused by “degassing” of the sample as it warms up running through the analyzer flow system. These bubbles can result in small measurement errors of a few tenths of a PPM. To eliminate the air buildup, the Q46F provides a simple automatic system to remove air accumulation. This system is activated by a timer (T2) that opens a solenoid valve once an hour. When the solenoid opens, the sample will drain below the sensor and remove any bubble accumulation.

The timer function T2 can be changed by the operator if desired. If the sample coming into the monitor is very cold, air removal more frequently might be necessary. In some cases, less frequent air removal may be fine. During the air removal process, the analog output and alarm relays are held at the values just prior to operation. To change frequency, go the Control Menu and adjust “T2 Tmr Cycle” to the frequency desired.

4.6 Fluoride Calibration Standards

The automatic calibration routine normally uses two fluoride standards that should be prepared in the 1 gallon containers provided for that purpose. The two fluoride standards used for most drinking water applications will be 1 PPM and 10 PPM, but other values can be used as long as there is at least 1 decade of concentration difference (10x) between the two. Also, standards below 1 PPM should be avoided and no standard below 0.5 PPM should be used.

Fluoride standards used for calibration should be mixed using the supplied concentrated standards and **unfluoridated raw water** for dilution. **Do not use distilled or deionized water to mix standards.** For highest accuracy, always use the same type of water that the analyzer will see in continuous operation.

Many water plant facilities are equipped with the materials and equipment to mix their own fluoride standards. As an option, ATI can supply a standards mixing kit containing measuring cylinders and fluoride standards to facilitate mixing. This kit contains 2 standards, 100 PPM and 1000 PPM. The 100 PPM standard should be used for mixing the 1 PPM calibration solution and the 1000 PPM standard should be used to mix the 10 PPM standard. Included in the kit is a 10 ml. graduated cylinder and a 1000 ml. graduated cylinder. The standards mixing kit is ATI part number 05-0108.

4.61 Mixing Standards

As mentioned previously, ATI's fluoride calibration kit provides everything needed to mix 1 and 10 PPM standards for use in calibration of the Q46F. The following procedures are used to mix 1 liter volumes of 1 and 10 PPM standards, which should then be transferred to the 1 gallon containers provided. You will normally need to mix 2 or 3 liters of each standard to fill the gallon containers to a reasonable level.

To mix a 1 PPM standard, fill the 10 ml. graduated cylinder to the 10 ml. mark with the 100 PPM standard. Pour this solution into the 1000 ml. graduated cylinder and fill to the 1000 ml. mark with **fluoride free raw water**. Pour this solution into the gallon container labeled 1 PPM. Repeat this 2 more times to provide 3 liters of 1 PPM standard.

To mix a 10 PPM standard, fill the 10 ml. graduated cylinder to the 10 ml. mark with the 1000 PPM standard. Pour this solution into the 1000 ml. graduated cylinder and fill to the 1000 ml. mark with **fluoride free raw water**. Pour this solution into the gallon container labeled 10 PPM. Repeat this 2 more times to provide 3 liters of 10 PPM standard.

Part 5 – Configuration

5.1 User Interface

The user interface for the Q46 Series instrument consists of a custom display and a membrane keypad. All functions are accessed from this user interface (no internal jumpers, pots, etc.).

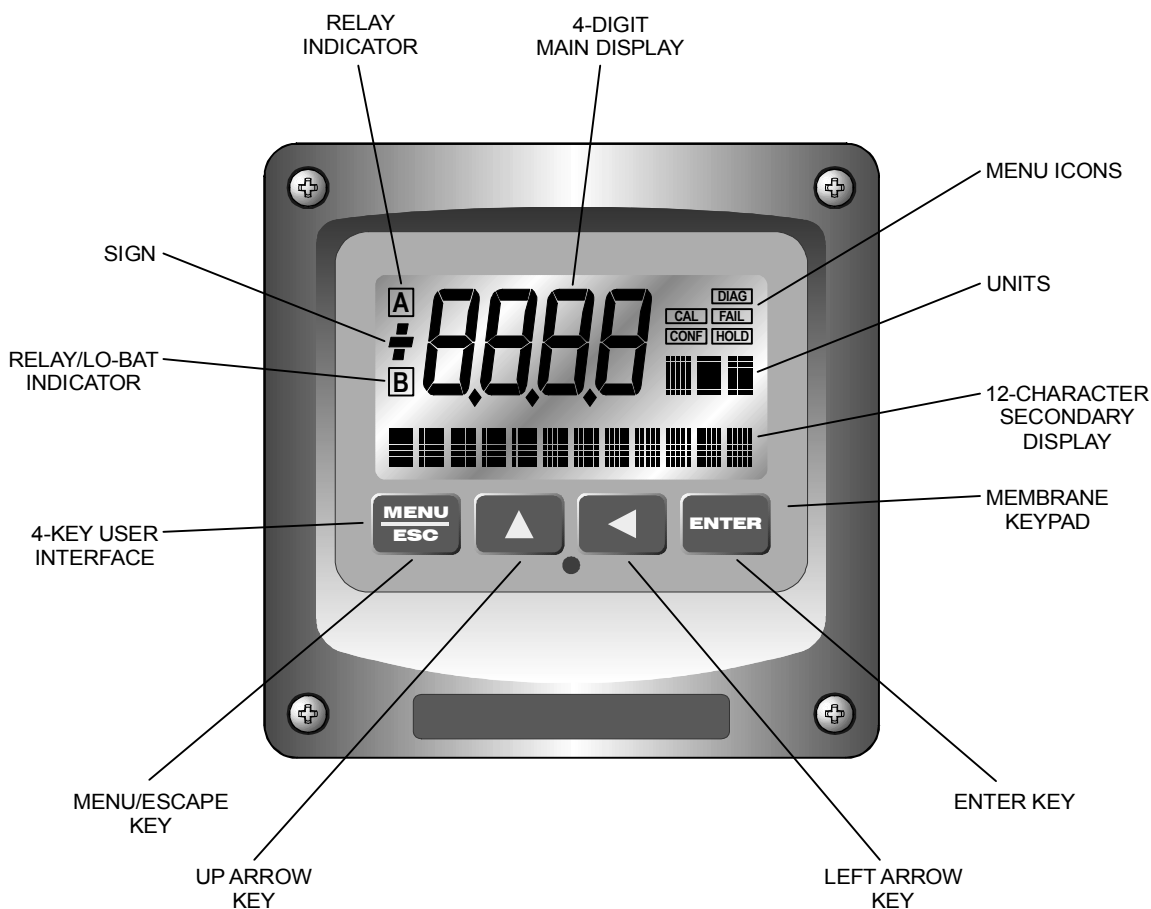

Figure 17 - User Interface

5.11 Keys

All user configurations occur through the use of four membrane keys. These keys are used as follows:

- MENU/ESC** To scroll through the menu section headers or to escape from anywhere in software. The escape sequence allows the user to back out of any changes in a logical manner. Using the escape key aborts all changes to the current screen and backs the user out one level in the software tree. The manual will refer to this key as either MENU or ESC, depending upon its particular function. In the battery-powered version of the Q46, this is also the ON button.
- UP (arrow)** To scroll through individual list or display items and to change number values.
- LEFT (arrow)** To move the cursor from right to left during changes to a number value.
- ENTER** To select a menu section or list item for change and to store any change.

5.12 Display

The large custom display provides clear information for general measurement use and user configuration. There are three main areas of the display: the main parameter display, the secondary message line, and the icon area.

- Main Parameter** During normal operation, the main parameter display indicates the present process input with sign and units. This main display may be configured to display any of the main measurements that the system provides. During configuration, this area displays other useful set-up information to the user.



Lower Line

During normal operation, the lower line of the display indicates user-selected secondary measurements that the system is making. This also includes calibration data from the last calibration sequence and the transmitter model number and software version. During configuration, the lower line displays menu items and set-up prompts to the user. Finally, the lower line will display error messages when necessary. For a description of all display messages, refer to Section 9.4.

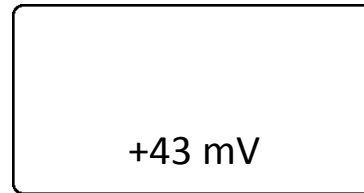
**Icon Area**

The icon area contains display icons that assist the user in set-up and indicate important states of system functions. The CAL, CONFIG, and DIAG icons are used to tell the user what branch of the software tree the user is in while scrolling through the menu items. This improves software map navigation dramatically. Upon entry into a menu, the title is displayed (such as CAL), and then the title disappears to make way for the actual menu item. However, the icon stays on.

**HOLD**

The HOLD icon indicates that the current output of the transmitter has been put into output hold. In this case, the output is locked to the last input value measured when the HOLD function was entered. HOLD values are retained even if the unit power is cycled.

FAIL

The FAIL icon indicates that the system diagnostic function has detected a problem that requires immediate attention. This icon is automatically cleared once the problem has been resolved.

Relay Area A/B

The relay area contains two icons that indicate the state of the system relays (if the relay card is installed). Relay C is normally configured for FAIL indication, so it is only displayed on the lower MEASURE display line.



5.2 Software

The software of the Q46F is organized in an easy to follow menu-based system. All user settings are organized under five menu sections: Measure, Calibration [CAL], Configuration [CONFIG], Control [CONTROL] and Diagnostics [DIAG].

Note: The default Measure Menu is display-only and has no menu icon.

5.2.1 Software Navigation

Within the CAL, CONFIG, CONTROL, and DIAG menu sections is a list of selectable items. Once a menu section (such as CONFIG) has been selected with the MENU key, the user can access the item list in this section by pressing either the ENTER key or the UP arrow key. The list items can then be scrolled through using the UP arrow key. Once the last item is reached, the list wraps around and the first list item is shown again. The items in the menu sections are organized such that more frequently used functions are first, while more permanent function settings are later in the list. See Figure 18 for a visual description of the software.

Each list item allows a change to a stored system variable. List items are designed in one of two forms: simple single variable, or multiple variable sequences. In the single variable format, the user can quickly modify one parameter - for example, changing the display range from 2.000 to 20.00. In the multiple variable sequence, variables are changed as the result of some process. For example, the calibration of fluoride generally requires more than one piece of information to be entered. The majority of the menu items in the software consist of the single variable format type.

Any data that may be changed will be flashing. This flashing indicates user entry mode and is initiated by pressing the ENTER key. The UP arrow key will increase a flashing digit from 0 to 9. The LEFT arrow key moves the flashing digit from right to left. Once the change has been completed, pressing ENTER again stores the variable and stops the flashing. Pressing ESC aborts the change and also exits user entry mode.

The starting (default) screen is always the Measure Menu. The UP arrow key is used to select the desired display. From anywhere in this section the user can press the MENU key to select one of the four Menu Sections.

The UP arrow icon next to all list items on the display is a reminder to scroll through the list using the UP arrow key.

To select a list item for modification, first select the proper menu with the MENU key. Scroll to the list item with the UP arrow key and then press the ENTER key. This tells the system that the user wishes to perform a change on that item. For single item type screens, once the user presses the ENTER key, part or all of the variable will begin to flash, indicating that the user may modify that variable using the arrow keys. However, if the instrument is locked, the transmitter will display the message **Locked!** and will not enter user entry mode. The instrument must be unlocked by entering the proper code value to allow authorized changes to user entered values. Once the variable has been reset, pressing the ENTER key again causes the change to be stored and the flashing to stop. The message **Accepted!** will be displayed if the change is within pre-defined variable limits. If the user decides not to modify the value after it has already been partially changed, pressing the ESC key aborts the modification and returns the entry to its original stored value.

In a menu item which is a multiple variable sequence type, once the ENTER key is pressed there may be several prompts and sequences that are run to complete the modification. The ESC key can always be used to abort the sequence without changing any stored variables.

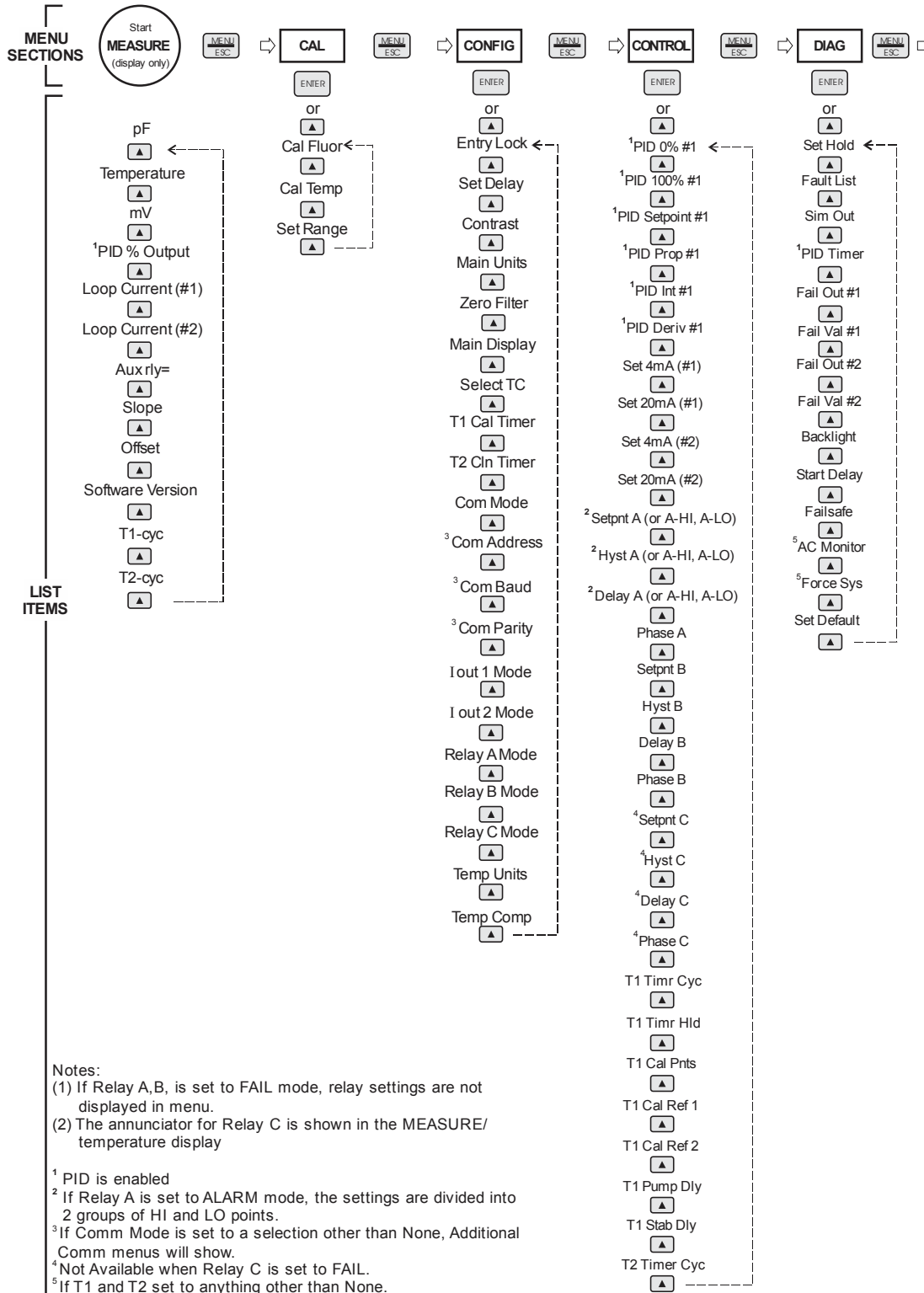

Figure 18 - Software Map

5.22 Measure Menu [MEASURE]

The default menu for the system is the display-only menu MEASURE. This menu is a display-only measurement menu, and has no changeable list items. When left alone, the instrument will automatically return to this menu after approximately 30 minutes. While in the default menu, the UP arrow allows the user to scroll through the secondary variables on the lower line of the display. A brief description of the fields in the basic transmitter version is as follows:

TRANSMITTER MEAS SCREENS:

pF	Similar to pH, but using F^- concentration. Calculated by $-\log [F^-]$.
25.7C	Temperature display. User selectable for °C or °F. A small “m” on the left side of the screen indicates the monitor has automatically jumped to a manual 25C setting due to a failure with the temperature signal input.
-32.3 mV	Raw sensor potential. Useful for diagnosing problems.
100% 20.00 mA	PID Status screen (if enabled.) Shows the present controller output level on left, and actual transmitter current on the right. The controller can be placed in manual while viewing this screen by pressing and holding the ENTER key for 5 seconds until a small flashing “m” appears on the screen. At that point the controller output can be adjusted up or down using the UP and LEFT arrow keys. To return to automatic operation, press and hold the ENTER key for 5 seconds and the “M” will disappear.
4.00 mA	Transmitter output current # 1
20.00 mA	Transmitter output current # 2
Slope = 100%	Sensor output response vs. ideal calibration. This value updates after each calibration. As the sensor ages, the slope reading will decay indicating sensor aging. Useful for resolving sensor problems.
Offset = 0.0 mv	This is a “calculated value” which indicates the theoretical mv. value that would be generated at 0 PPM fluoride. Since selective ion sensors do not actually respond down to dead zero, this value is displayed simply to track sensor stability.
Q46F VX.XX	Transmitter software version number.

- T1-cyc** Time remaining until next auto-calibration cycle.
- T2-cyc** Time remaining until next flowcell auto-clear cycle. This removes air bubbles from the face of the fluoride electrode.

Note: A display test (all segments ON) can be actuated by pressing and holding the ENTER key while viewing the model/version number on the lower line of the display.

An auto-calibration or auto-clear cycle can be activated manually by holding the ENTER key while viewing either of the T-cyc values.

The MEASURE screens are intended to be used as a very quick means of looking up critical values during operation or troubleshooting.

5.23 Calibration Menu [CAL]

The calibration menu contains items for frequent calibration of user parameters. There are three items in this list: Cal Fluoride, Cal Temp. and Set Range.

Cal The fluoride calibration function allows the user to adjust the transmitter span reading to match a reference solution, or to set the sensor zero point. See Part 6 - Calibration for more details.

Cal Temp The temperature calibration function allows the user to adjust the offset of the temperature response by a small factor of ± 5 °C. The temperature input is factory calibrated to very high accuracy. However, long cable lengths and junction boxes may degrade the accuracy of the temperature measurement in some extreme situations. Therefore, this feature is provided as an adjustment. See Part 6 - Calibration for more details.

Set Range This function allows the user to set the display range of the transmitter to a specific application. Once set, all output functions use this display range to establish configuration settings. Press ENTER to initiate user entry mode, and the value will flash. Use the arrow keys to modify value; available ranges include 20.00 ppm, 200.0 ppm, and 2000 ppm. Press ENTER to store the new value.

5.24 Configuration Menu [CONFIG]

The Configuration Menu contains all of the general user settings:

- Entry Lock** This function allows the user to lock out unauthorized tampering with instrument settings. All settings may be viewed while the instrument is locked, but they cannot be modified. The Entry Lock feature is a toggle-type setting; that is, entering the correct code will lock the transmitter and entering the correct code again will unlock it. The code is preset at a fixed value. Press ENTER to initiate user entry mode and the first digit will flash. Use arrow keys to modify value. **See Page 65 for the Q46F lock/unlock code.** Press ENTER to toggle lock setting once code is correct. Incorrect codes do not change state of lock condition.
- Set Delay** The delay function sets the amount of damping on the instrument. This function allows the user to apply a first order time delay function to the fluoride measurements being made. Both the display and the output value are affected by the degree of damping. Functions such as calibration are not affected by this parameter. The calibration routines contain their own filtering and stability monitoring functions to minimize the calibration timing. Press ENTER to initiate user entry mode, and the value will flash. Use the arrow keys to modify value; range is 0.1 to 9.9 minutes. Press ENTER to store the new value.
- Contrast** This function sets the contrast level for the display. The custom display is designed with a wide temperature range, Super-Twist Nematic (STN) fluid.
- The STN display provides the highest possible contrast and widest viewing angle under all conditions. Contrast control of this type of display is generally not necessary, so contrast control is provided as a means for possible adjustment due to aging at extreme ranges. In addition, the display has an automatic temperature compensation network. Press ENTER to initiate user entry mode, and the value will flash. Use arrow keys to modify the value; range is 0 to 8 (0 being lightest). Press ENTER to update and store the new value.
- Main Units** This function allows the user to select either PPM or mg/l.

Zero Filter	This function forces the reading to zero when reading is below the entered value. For example, if the entered value were 0.0020 the display at 0-0019 would indicate 0.000. This feature is useful in blanking out zero noise.
Main Display	This function allows the user to change the measurement in the primary display area. The user may select between fluoride or output current. Using this function, the user may choose to put output current in the main display area and fluoride on the secondary, lower line of the display. Press ENTER to initiate user entry mode, and the entire value will flash. Use the UP arrow key to modify the desired display value. Press ENTER to store the new value.
Select TC	This function allows the user to select either 100 or 1000 Ohm RTD for temperature compensation.
T1 Cal Tmer	This function allows the user to turn on/off the auto-calibration routine.
T2 Cln Tmer	This function allows the user to turn on/off the flowcell auto-purge routine. The purge system drops the sample level just below the level of the sensor tip to eliminate bubbles that can accumulate there.
Com Mode	Sets digital communication mode of analyzer. Optional digital communication card must be plugged into the power supply slot for this function to work. Press ENTER to initiate user entry mode, and the entire value will flash. Use the UP arrow key to modify the desired value; selections include 1-None, 2- P-DP for Profibus DP, 3 – Modbus, 4 – Ethernet IP. Press ENTER to store the new value.
Com Address	Sets bus address for digital communication mode of analyzer. Optional digital communication card must be plugged into the power supply slot for this function to work. Press ENTER to initiate user entry mode, and the entire value will flash. Use the UP arrow key to modify the desired value. Range is 1-125. Press ENTER to store the value.
Com Baud	Sets communications baud rate.
Com Parity	Sets parity for the digital communications.

lout#1 Mode This function sets analog output #1 to either track fluoride (default) or enables the PID controller to operate on the fluoride input. Press ENTER to initiate user entry mode, and the entire value will flash. Use the UP arrow key to modify the desired value; selections include 1-ppm for fluoride tracking or 2-PID for fluoride PID control. Press ENTER to store the new value.

***lout#2 Mode** This function sets analog output #2 for either temperature or fluoride. Press ENTER to initiate user entry mode, and the entire value will flash. Use the UP arrow key to modify the desired value; selections include: 1-ppm for temperature, or 2-PPM for fluoride. Press ENTER to store the new value.

***Rly A Mode** Relay A can be used in three different ways: as a setpoint control, as a fail alarm, or as a HI-LO alarm band. The three settings for Rly A Mode are **CON**, **FAIL** and **AL**.

The **CON** setting enables normal control operation for Relay A, with settings for setpoint, hysteresis, delay and phasing appearing in the CONFIG menu automatically. See Figure 19 for further details.

The **FAIL** setting enables the fail alarm mode for Relay A. Relay A will then trip on any condition that causes the FAIL icon to be displayed on the LCD. Using this mode allows the User to send alarm indications to other remote devices.

The **AL** setting allows two setpoints to be selected for the same relay, producing a HI-LO alarm band. In this mode, Relay A will trip inside or outside of the band, depending upon the Phase selected. See Figure 20 for further details.

Relay B Mode
Relay C Mode

Relay B and C can be used in two ways: as a setpoint control, or as an alarm. The two settings for Relay B Mode are **CON** and **FAIL**.

The **CON** setting enables normal setpoint operation for Relay B/C. Relay B/C then operates identically to Relay A, with settings for setpoint, hysteresis, delay and phasing appearing in the CONFIG menu automatically. See Figure 19 for details.

The **FAIL** setting enables the fail alarm mode for Relay B/C. Relay B/C will then trip on any condition that causes the FAIL icon to be displayed on the LCD. Note that the Relay C indicator shows up only on the lower screen of the display next to the temperature reading. This is because the default setting for relay C is the **FAIL** setting. Using this mode allows the User to send alarm indications to other remote devices.

Temp Comp This function allows the user to turn on/off the temperature compensation feature.

5.25 Control Menu [CONTROL]

The Control Menu contains all of the output control user settings:

Set 4 mA
Set 20 mA
[lout1=PPM]

These functions set the main 4 and 20 mA current loop output points for the transmitter. The units displayed depend on the selection made in the CONFIG menu for lout #1 Mode.

The value stored for the 4 mA point may be higher or lower than the value stored for the 20 mA point. The entry values are limited to values within the range specified in “Set Range”, and the 4 mA and the 20 mA point must be separated by at least 1% of this range. Use the LEFT arrow key to select the first digit to be modified. Then use the UP and LEFT arrow keys to select the desired numerical value. Press ENTER to store the new value.

Set PID 0%
Set PID 100%
[lout1=PID]

If the PID is enabled, this function sets the minimum and maximum controller end points. Unlike the standard 4-20 mA output, the controller does not “scale” output values across the endpoints. Rather, the endpoints determine where the controller would normally force minimum or maximum output in an attempt to recover the setpoint (even though the controller can achieve 0% or 100% anywhere within the range.)

If the 0% point is lower than the 100% point, then the controller action will be “reverse” acting. That is, the output of the controller will increase if the measured value is less than the setpoint, and the output will decrease if the measured value is larger than the setpoint. Flipping the stored values in these points will reverse the action of the controller to “direct” mode.

The entry value is limited to a value within the range specified in “Set Range”, and the 0% and the 100% point must be separated by at least 1% of this range. Use the LEFT arrow key to select the first digit to be modified. Then use the UP and LEFT arrow keys to select the desired numerical value. Press ENTER to store the new value.

PID Setpnt
[lout1=PID]

The measured value which the controller is attempting to maintain by adjusting output value. It is the nature of the PID controller that it never actually gets to the exact value and stops. The controller is continually making smaller and smaller adjustments as the measured value gets near the setpoint.

PID Prop
[lout1=PID]

Proportional gain factor. The proportional gain value is a multiplier on the controller error (difference between measured value and setpoint value.) Increasing this value will make the controller more responsive.

PID Int
[lout1=PID]

Integral is the number of “repeats-per-minute” of the action of the controller. It is the number of times per minute that the controller acts on the input error. At a setting of 2.0 rpm, there are two repeats every minute. If the integral is set to zero, a fixed offset value is added to the controller (manual reset.) Increasing this value will make the controller more responsive.

PID Deriv
[Iout1=PID]

Derivative is a second order implementation of Integral, used to suppress “second-order” effects from process variables. These variables may include items like pumps or mixers that may have minor impacts on the measured value. The derivative factor is rarely used in water treatment process, and therefore, it is best in most cases to leave it at the default value. Increasing this value will make the controller more responsive.

***Set 4 mA #2**
***Set 20 mA #2**
[Temp / PPM]

These functions set the second 4 mA and 20 mA current loop output points for the transmitter. The default setting for this output is temperature, but it may be set for PPM if preferred. The values stored for the 4 mA point may be higher or lower than the value stored for the 20 mA point.

The entry value is limited to a value between 0 and 55°C if it is set for temperature. The 4 mA and the 20 mA point must be at least 20 units away from each other. Press ENTER to initiate user entry mode, and the value will flash. Use arrow keys to modify value. Press ENTER to store the new value.

NOTE: If the temperature units are changed between °C and °F (see Temp Units in CONFIG section), the default setting for this output will change between 100°C and 212°F accordingly

***A Setpoint**

This function establishes the trip point for relay A. The entry value is limited to a value within the range specified in “Set Range”. Use the LEFT arrow key to select the first digit to be modified. Then use the UP and LEFT arrow keys to select the desired numerical value. Press ENTER to store the new value.

***A Hysteresis**

This function establishes the hysteresis, or “deadband”, for Relay A. Hysteresis is most often used to control relay chattering; however, it may also be used in control schemes to separate the ON/OFF trip points of the relay. Press ENTER to initiate user entry mode, and the value will flash. Use the arrow keys to modify value. Press ENTER to store the new value.

***A Delay**

This function places an additional amount of time delay on the trip point for relay A. This delay is in addition to the main delay setting for the controller. The entry value is limited to a value between 0 and 999 seconds. Press ENTER to initiate user entry mode, and the value will flash. Use arrow keys to modify value; range is 0 to 999 seconds. Press ENTER to store the new value.

***A Phasing**

This function establishes the direction of the relay trip. When phase is HI, the relay operates in a direct mode. Therefore, the relay energizes and the LCD indicator illuminates when the value **exceeds** the setpoint. When the phase is LO, the relay energizes and the LCD indicator illuminates when the fluoride level drops **below** the setpoint. The failsafe setting does have an impact on this logic. The description here assumes the failsafe setting is OFF. Press ENTER to initiate user entry mode, and the entire value will flash. Use the UP arrow key to modify the desired value; selections include **HI** for direct operation or **LO** for reverse operation. Press ENTER to store the new value.

See Figure 19 below for a visual description of a typical control relay application.

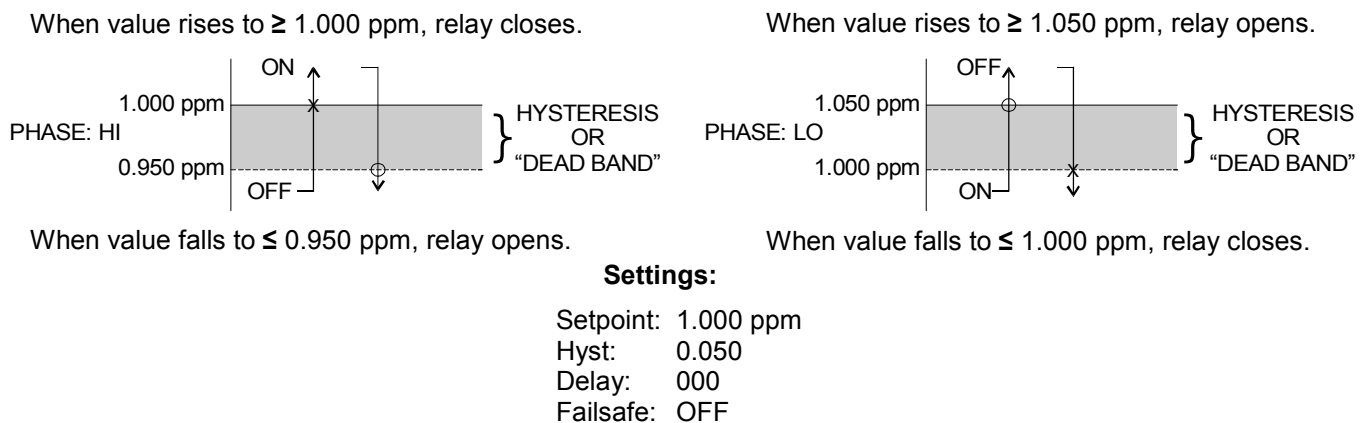

Figure 19 - Control Relay Example

- *Setpnt A-HI
- *Hyst A-HI
- *Delay A-HI
- *Setpnt A-LO
- *Hyst A-LO
- *Delay A-LO

If Relay A Mode is set to Alarm Mode, **AL**, then the following settings will appear in the Config Menu list automatically. In this mode, two setpoints can be selected on the same relay, to create an alarm band. Phase HI selection causes the relay to energize outside of the band, and Phase LO causes the relay to energize inside of the band. This feature enables one relay to be used as a control relay while the other is used as a HI-LO Alarm relay at the same time. Setpoint A-LO must be set lower than Setpoint A-HI. When AL mode is first selected, Setpoint A-LO is defaulted to 0.

Figure 2020 is a visual description of a typical alarm relay application.

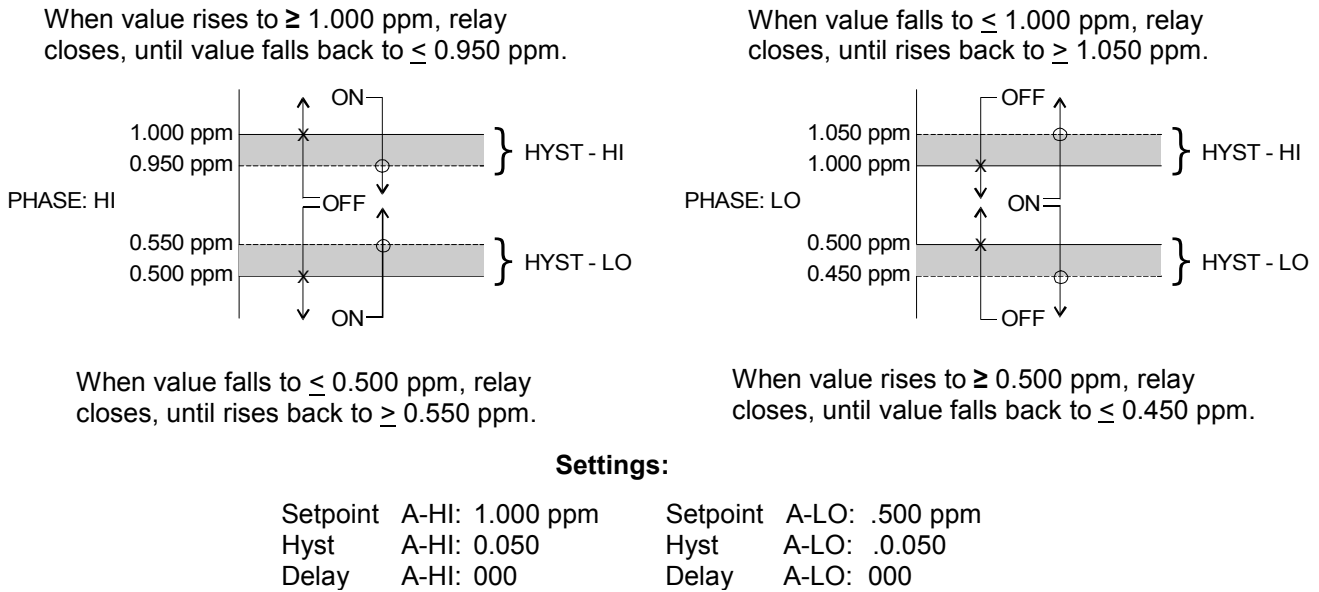

Figure 20 - Alarm Relay Example

- *B Setpoint
- *B Hysteresis
- *B Delay
- *B Phasing

If Relay B Mode is set to CON (see Relay B Mode), then Relay B will function identically to Relay A. Relay B settings appear in the CONFIG menu list automatically

- *C Setpoint
- *C Hysteresis
- *C Delay
- *C Phasing

If Relay C Mode is set to CON (see Relay C Mode), then Relay C will function identically to Relay A. Relay C settings appear in the CONFIG menu list automatically.

T1 Timr Cyc	This is the cyclic time for the auto-calibration to occur. Values range from 1-999 hours. <u>The default is 24 hours.</u>
T1 Timr Hld	This is the time delay to keep outputs held after the entire auto-calibration cycle is complete. <u>The default is 1 minute.</u>
T1 Cal Pnts	The number of calibration points to be used in the auto-calibration. 1 or 2 points selectable. <u>The default is 2 point.</u>
T1 Cal Ref1	Value of the first calibration standard. Values range from 1.00 to 20.00 ppm. <u>The default is 1.00 PPM</u>
T1 Cal Ref2	Value of the second calibration standard. Values range from 1.00 to 20.00 ppm. <u>The default is 10.00 PPM</u>
T1 Pump Dly	This is the amount of time that a standard will be pumped prior to checking for stability of the reading on that standard. <u>The default is 1 minute.</u>
T1 Stab Dly	This is the time period over which a standard must be stable in order for the reading to be accepted. <u>The default is 0.3 minutes.</u>
T2 Tmer Cyc	This is the cyclic time for automatic clearing of air bubbles that may collect on the face of the fluoride electrode. <u>The default is 1 hour.</u>

5.26 Diagnostics Menu [DIAG]

The diagnostics menu contains all of the user settings that are specific to the system diagnostic functions, as well as functions that aid in troubleshooting application problems.

Set Hold	The Set Hold locks the analog output values on the present process value and halts operation of the PID controller. This function can be used prior to calibration, or when removing the sensor from the process, to hold the output in a known state. Once HOLD is released, the outputs return to their normal state. The transfer out of HOLD is bumpless on the both analog outputs - that is, the transfer occurs in a smooth manner rather than as an abrupt change. An icon on the display indicates the HOLD state and the HOLD state is retained even if power is cycled. Press ENTER to initiate user entry mode, and entire value will flash. Use the UP arrow key to modify the desired value, selections are ON for
-----------------	---

engaging the HOLD function, and **OFF** to disengage the function. Press ENTER to store the new value.

The Set Hold function can also hold at an output value specified by the user. To customize the hold value, first turn the HOLD function on. Press the ESC key to go to the DIAG Menu and scroll to Sim Output using the UP arrow key. Press ENTER. Follow the instructions under Sim Output (see following page).

Fault List

The Fault List screen is a read-only screen that allows the user to display the cause of the highest priority failure. The screen indicates the number of faults present in the system and a message detailing the highest priority fault present. Note that some faults can result in multiple displayed failures due to the high number of internal tests occurring. As faults are corrected, they are immediately cleared.

Faults are not stored; therefore, they are immediately removed if power is cycled. If the problem causing the faults still exists, however, faults will be displayed again after power is re-applied and a period of time elapses during which the diagnostic system re-detects them. The exception to this rule is the calibration failure. When a calibration fails, no corrupt data is stored. Therefore, the system continues to function normally on the data that was present before the calibration was attempted.

After 30 minutes or if power to the transmitter is cycled, the failure for calibration will be cleared until calibration is attempted again. If the problem still exists, the calibration failure will re-occur. Press ENTER to initiate view of the highest priority failure. The display will automatically return to normal after a few seconds.

Sim Out

The Sim Out function allows the user to simulate the fluoride concentration in the user selected display range. The user enters a ppm value directly onto the screen, and the output responds as if it were actually receiving the signal from the sensor. This allows the user to check the function of attached monitoring equipment during set-up or troubleshooting. Escaping this screen returns the unit to normal operation. Press ENTER to initiate the user entry mode, and the right-most digit of the value will flash. Use arrow keys to modify desired value.

PID Timer

This function sets a timer to monitor the amount of time the PID controller remains at 0% or 100%. This function only appears if the PID controller is enabled. If the timer is set to 0000, the feature is effectively disabled. If the timer value is set to any number other than zero, a FAIL condition occurs if the PID controller remains at 0% or 100% for the timer value. If one of the relays is set to FAIL mode, this failure condition can be signaled by a changing relay contact.

Press ENTER to initiate user entry mode, and the entire value will flash. Use the UP arrow key to modify desired value; range of value is 0-9999 seconds. Press ENTER to store the new value.

Fail Out #1

This function enables the user to define a specified value that the main current output will go to under fault conditions. When the Relay Option Board is installed, the display will read **Fail Out #1**. When enabled to **ON**, the output may be forced to the current value set in **Fail Val** (next item.) With the Fail Out setting of ON, and a Fail Val setting of 6.5 mA, any alarm condition will cause the current loop output to drop outside the normal operating range to exactly 6.5 mA, indicating a system failure that requires attention.

Press ENTER to initiate user entry mode, and the entire value will flash. Use the UP arrow key to modify desired value; selections are **ON**, **OFF**. Press ENTER to store the new value.

Fail Val #1

Sets the output failure value for lout#1. When **Fail Out** above is set to **ON**, this function sets value of the current loop under a FAIL condition. When the Relay Option Board is installed, the display will read **Fail Out #1**. The output may be forced to any current value between 4-20 mA.

Press ENTER to initiate user entry mode, and the entire value will flash. Use the UP arrow key to modify desired value; selections are between **4mA**, and **20mA**. Press ENTER to store the new value.

Fail Out #2

This function sets the fail-mode of current loop output #2 under a FAIL condition. The settings and operation are identical to Fail Out for output #1.

- Fail Val #2** This function sets the value of current loop output #2 under a FAIL condition. The settings and operation are identical to Fail Out for output #1.
- Backlight** This function has three options. **ON** – On all the time, **OFF** – Off all the time, **AL** – Alarm (Default). This function flashes the backlight on and off whenever the Fail icon is displayed.
- *Failsafe** This function allows the user to set the optional system relays to a failsafe condition. In a failsafe condition, the relay logic is reversed so that the relay is electrically energized in a normal operating state. By doing this, the relay will not only change state when, for example, a fluoride limit is exceeded, but also when power is lost to the controller.
- When failsafe is selected to be ON, the normally-open contacts of the relay will be closed during normal operation. In an attempt to make this configuration less confusing, the LCD icon logic is reversed with this setting, and the icon is OFF under this normal condition. Therefore, when the trip condition occurs, the closed N.O. contacts will be opened (relay de-energized), and the LCD icon will illuminate. In addition, a power fail would also cause the same contacts to open.
- Start Delay** This function is designed to minimize control or alarm issues arising from temporary power loss. When power goes down, the monitor records the analog output values and the status of relays and PID functions. When power is restored, the analog values and relays will be held at the pre-power loss values for a defined period of time. This “start delay” may be programmed for periods from 0-9.9 minutes. This function is set to 0.0 minutes by default and must be activated by the user if desired by setting a positive time value
- AC Monitor** AC Monitor stands for Auto-Cal Monitor. Under normal conditions, the analog outputs are held constant during an automatic calibration. If AC Monitor is turned to ON, output #1 will not be inhibited. The output will track the fluoride value as it changes during the calibration cycle. This allows a user to record the calibration as it occurs.

Force Sys

This function allows for manual operation of the 3 solenoid valves that control the automatic calibration system. When you press enter, the NO will flash. Pressing the UP key allows you to select “S1”, “S2”, or CLn. Selecting S1 and pressing Enter will activate the main selector valve, allowing the 1 PPM standard to flow into the system. The measured fluoride value is displayed on the lower line so you can use this function to manually feed the standard and observe whether or not the value is correct. Selecting S2 activates both the main valve and the standards selector valve, causing the 10 PPM standard to flow into the system. Selecting CLn activates the valve below the flowcell to test the air purge function.

Set Default

The Set Default function allows the user to return the instrument back to factory default data for all user settings. It is intended to be used as a last resort troubleshooting procedure. All user settings are returned to the original factory values. Hidden factory calibration data remains unchanged. Press ENTER to initiate user entry mode and the value **NO** will flash. Use the UP arrow key to modify value to **YES** and press ENTER to reload defaults.

Part 6 – Calibration

6.1 Calibration

Calibration of a fluoride analyzer requires the use of two standards with about 1 decade (10X) concentration difference. For many applications, values of 1 and 10 PPM are used. However, high range applications may require the use of 10 and 100 PPM or other values depending on the application. Prior to attempting calibration of a Q46F system, be sure that the sensor has been filled with electrolyte, that the buffer is being pumped into the sample, and that the analyzer has been running for 60 minutes.

Q46F analyzers are designed to do an automatic 2-point calibration. Gallon bottles containing 1 and 10 PPM fluoride should be connected to the instrument using the red and blue tubing supplied for that purpose. These tubes must be positioned properly in the pinch valve used to select each standard during the calibration cycle. The pinch valve has the red tube in the normally closed (front) position and the blue tube in the normally open (rear) position.

6.11 Automatic Calibration

Prior to calibration, check the following settings:

1. In the Configuration Menu, be sure that “T1 Cal Tmr” is turned ON.
2. In the Control Menu, verify the following settings in the Control Menu.

T1 Timr Cyc: Set to 24 hours (or other desired calibration frequency)

T1 Timr Hld: Set to 1 minute.

T1 Cal Pnts: Normally set for 2 point calibration. Can be set for 1-point if desired.

T1 Cal Ref1: Set to 1.00 ppm. Set to different value if desired.

T1 Cal Ref2: Set to 10.00 ppm. Set to 10x Ref1 if using other than 1 and 10 PPM.

T1 Pump Dly: Normally set to 1 minute. Set to longer period if desired.

T1 Stab Dly: Normally set to 0.3 minutes. Set to longer period for additional stability check.

To activate the calibration cycle starting from the MEAS Menu, press the UP arrow until the display indicates “T1 cyc – XX.Xh” (XX.X will be the number of hours until the next automatic calibration). With the T1 display showing, press and hold the Enter key for about 3 seconds. This will start the cycle.

When the cycle is started, the pinch valve directly below the sensor flowcell will open for about 3 seconds to remove any bubbles that might have accumulated on the face of the sensor. Shortly after that, the larger pinch valve directly below the sample pump will cycle, closing off the normal sample and allowing 1 PPM standard to flow. The display will count down the time until the analyzer will begin monitoring the sensor stability at 1 PPM. If the sensor output is stable for the time period programmed for stability testing, then the standards selector valve will switch to the 10 PPM standard. Once the 10 PPM standard has been judged to be stable, the analyzer will calculate an offset and slope value that indicates the performance of the sensor.

6.12 Manual Calibration

Should you prefer to do a manual calibration instead of using the automatic system, you will need to disconnect the pump inlet tube from the inlet chamber. The connection is a luer fitting on the cover of the inlet overflow as shown in the photo on page 16. An extension tube that mates with the luer fitting is provided so that standards can be fed through the normal pump inlet.

Once the extension tube has been connected, remove the rubber stoppers from the top of the 1 and 10 PPM standards bottles so that your extension tube can be inserted into these bottles. Start by putting the extension tube into the 1 PPM standard and then proceed as follows:

1. Press the Menu key once to access the Cal. Menu. Press the UP arrow to display “Cal Fluor”.
2. Press Enter and display will indicate “2-point” calibration.
3. Press Enter again and the display will ask for standard number 1. Since you already have 1 PPM running through the system, press Enter and the system will begin checking for the stability of the 1 PPM sensor signal.
4. When the monitor determines that the signal is stable, the display will switch to a concentration number and the first digit will be flashing. Assuming you have a 1 PPM standard running, use the up arrow to set the first digit to 1. Then use the left arrow to move the second digit and set it to 0. Move left again and set the value to 0. You will now have 1.00 displayed. Press Enter to store that value.

5. The display will then prompt for the second standard. Move your inlet tube from the 1 PPM to the 10 PPM standard and allow it to run for at least 1 minute before doing anything. Then press Enter.
6. The monitor will again check for stability. After sensing a stable signal, you will be prompted to enter the second reference value. For a 10 PPM standard, enter 10.00 using the same procedure as the previous step.
7. Once 10.00 is set, press Enter and the manual calibration will be complete.
8. Disconnect the extension tube and attach the pump inlet fitting to the overflow to return to normal operation.

6.13 Single Point Manual Calibration

Some users may prefer to simply calibrate the monitor to a value determined using a separate test kit. This can be done easily, but a 2-point calibration must be done first in order to establish the slope of the sensor. If you prefer to calibrate to a lab value and simply use the mixed 1 and 10 PPM standards to establish the slope, first start the automatic calibration cycle and allow it to go through a complete calibration cycle. Then proceed as follows:

1. Collect a 300-500 ml. container of sample. Take a portion of that sample and test it using your colorimetric fluoride test kit or lab fluoride electrode.
2. Disconnect the sample inlet line and connect the extension tube. Place the end of the extension tube into the sample container.
3. Press the Menu key to go to the “Cal Fluor” display and then press Enter.
4. When the “2-point” prompt appears, press the UP key to change to 1-point and then press Enter. The monitor will prompt you for your reference solution. Press Enter.
5. When the concentration is displayed after stability testing, adjust the value on the display to the value determined by your lab test. Then press Enter.
6. You single point offset calibration is complete.
7. Disconnect your extension tube and reconnect the sample inlet to the overflow fitting.

6.2 Temperature Calibration

The temperature calibration sequence is essentially a 1-point offset calibration that allows adjustments of approximately ± 5 °C.

The temperature element is measuring the temperature of the sample inside the air stripping chamber. This temperature may, or may not, be close to the temperature of the water in the inlet overflow. Heat generated inside the chemistry module can sometimes cause the displayed temperature to be above the actual sample temperature. While temperature calibration is possible, it is not recommended. If you wish to calibrate the temperature system, proceed as follows:

1. Scroll to the CAL menu section using the MENU key and press ENTER or the UP arrow key.
2. Press the UP arrow key until **Cal Temp** is displayed.
3. Press the ENTER key. The message **Place sensor in solution then press ENTER** will be displayed. *Press ENTER to begin the calibration sequence.*
4. The calibration data gathering process will begin. The message **Wait** will flash as data is accumulated and analyzed. The °C or °F symbol may flash periodically if the reading is too unstable.
5. The message **Adjust value - press ENTER** will be displayed, and the right-most digit will begin to flash, indicating that the value can be modified. Using the UP and LEFT arrow keys, modify the value to your measured value. Adjustments up to ± 5 °C from the factory calibrated temperature are allowed. Press ENTER.

Once completed, the display will indicate **PASS** or **FAIL**. If the unit fails, the temperature adjustment may be out of range, the sensor may not have achieved complete temperature equilibrium, or there may be a problem with the temperature element. In the event of calibration failure, it is recommended to attempt the calibration again immediately.

Part 7 – PID Controller Details

7.1 PID Description

PID control, like many other control schemes, are used in chemical control to improve the efficiency of chemical addition or control. By properly tuning the control loop that controls chemical addition, only the amount of chemical that is truly required is added to the system, saving money. The savings can be substantial when compared to a system which may be simply adding chemical at a constant rate to maintain some minimal addition under even the worst case conditions. The PID output controller is highly advantageous over simple control schemes that just utilize direct (proportional only) 4-20 mA output connections for control, since the PID controller can automatically adjust the “rate” of recovery based on the error between the setpoint and the measured value – which can be a substantial efficiency improvement..

The PID controller is basically designed to provide a “servo” action on the 4-20 mA output to control a process. If the user requires that a measured process stay as close as possible to a specific setpoint value, the controller output will change from 0% to 100% in an effort to keep the process at the setpoint. To affect this control, the controller must be used with properly selected control elements (valves, proper chemicals, etc.) that enable the controller to add or subtract chemical rapidly enough. This is not only specific to pumps and valves, but also to line sizes, delays in the system, etc.

This section is included to give a brief description of tuning details for the PID controller, and is not intended to be an exhaustive analysis of the complexities of PID loop tuning. Numerous sources are available for specialized methods of tuning that are appropriate for a specific application.

7.2 PID Algorithm

As most users of PID controllers realize, the terminology for the actual algorithm terms and even the algorithms themselves can vary between different manufacturers. This is important to recognize as early as possible, since just plugging in similar values from one controller into another can result in dramatically different results. There are various basic forms of PID algorithms that are commonly seen, and the implementation here is the most common version; The ISA algorithm (commonly referred to as the “ideal” algorithm.)

$$\text{output} = P \left[e(t) + \frac{1}{I} \int e(t) dt + D \frac{de(t)}{dt} \right]$$

Where:

Output =	controller output
P =	proportional gain
I =	integral gain
D =	derivative gain
t =	time
e(t) =	controller error (e=measured variable – setpoint)

Figure 21 - Q46 ISA PID Equation

The most notable feature of the algorithm is the fact the proportional gain term affects all components directly (unlike some other algorithms - like the “series” form.) If a pre-existing controller utilizes the same form of the algorithm shown above, it is likely similar settings can for made if the units on the settings are exactly the same. Be careful of this, as many times the units are the reciprocals of each other (i.e. reps-per-min, sec-per-rep.)

PID stands for “proportional, integral, derivative.” These terms describe the three elements of the complete controller action, and each contributes a specific reaction in the control process. The PID controller is designed to be primarily used in a “closed-loop” control scheme, where the output of the controller directly affects the input through some control device, such as a pump, valve, etc.

Although the three components of the PID are described in the setting area (section 6.25), here are more general descriptions of what each of the PID elements contribute to the overall action of the controller.

P Proportional gain. With no “I” or “D” contribution, the controller output is simply a factor of the proportional gain multiplied by the input error (difference between the measured input and the controller setpoint.) Because a typical chemical control loop cannot react instantaneously to a correction signal, proportional gain is typically not efficient by itself – it must be combined with some integral action to be useful. Set the P term to a number between 2-4 to start. Higher numbers will cause the controller action to be quicker.

- I Integral gain. Integral gain is what allows the controller to eventually drive the input error to zero – providing accuracy to the control loop. It must be used to affect the accuracy in the servo action of the controller. Like proportional gain, increasing integral gain results in the control action happening quicker. Set the I term to a number between 3-5 to start (1-2 more than P). Like proportional gain, increasing the integral term will cause the controller action to be quicker.

- D Derivative gain. The addition of derivative control can be problematic in many applications, because it greatly contributes to oscillatory behavior. In inherently slow chemical control process', differential control is generally added in very small amounts to suppress erratic actions in the process that are non-continuous, such as pumps and valves clicking on and off. However, as a starting point for chemical process control, its best to leave the "D" term set to 0.

Based on these descriptions, the focus on tuning for chemical applications really only involves adjustment of "P" and "I" in most cases. However, increasing both increases the response of the controller. The difference is in the time of recovery. Although combinations of high "P's" and low "I" will appear to operate the same as combinations of low "P's" and high "I's", there will be a difference in rate of recovery and stability. Because of the way the algorithm is structured, large "P's" can have a larger impact to instability, because the proportional gain term impacts all the other terms directly. Therefore, keep proportional gain lower to start and increase integral gain to achieve the effect required.

Many of the classical tuning techniques have the user start with all values at 0, and then increase the P term until oscillations occur. The P value is then reduced to $\frac{1}{2}$ of the oscillatory value, and the I term is increased to give the desired response. This can be done with the Q46F controller, with the exception that the I term should start no lower than 1.0.

If it appears that even large amounts of integral gain (>20) don't appreciably increase the desired response, drop I back to about 1.0, and increase P by 1.00, and start increasing I again. In most chemical control schemes, I will be approximately 3 times the value of P.

7.3 Classical PID Tuning

Unlike many high speed position applications where PID loops are commonly used, the chemical feed application employed by this instrument does not require intense mathematical exercise to determine tuning parameters for the PID. In fact, the risk of instability is far greater with overly tuned PID control schemes. In addition, many of the classical mathematical exercises can be damaging or wasteful in the use of chemicals when the process is bumped with large amounts of input error to seek a response curve. Because of this, the general adjustment guidelines described in section 7.2 are sufficient for almost all application tuning for this instrument. Beyond this, many sources are available for classical tuning methods.

7.4 Manual PID Override Control

The Q46 PID output function allows the user to take manual control of the PID control signal. This is often useful when starting up a control loop, or in the event that you wish to bump the system manually to measure system response time.

To access the manual PID control, you must be in the MEASURE mode of operation and you must have the PID output displayed on the lower line. This line will indicate “XX.X% XX.X mA” with the X values simply indicating the current values. With this display on the screen, press and hold the ENTER key for about 5 seconds. You will see a small “m” show up between the % value and the mA value. This indicates you are now in manual mode.

Once in manual, you may increase the PID output by pressing the UP arrow or you may decrease the output by pressing the LEFT arrow. This will allow you to drive the PID output to any desired setting.

To revert to normal PID control, press and hold the ENTER key again until the “m” indicator disappears.

7.5 Common PID Pitfalls

The most common problem occurring in PID control applications involves the false belief that proper settings on only the PID controller can balance any process to an efficient level.

Close-loop control can only be effective if all elements in the loop are properly selected for the application, and the process behavior is properly understood. Luckily, the nature of simple chemical control process' are generally slow in nature. Therefore, even a de-tuned controller (one that responds somewhat slowly) can still provide substantial improvements to setpoint control. In fact, damaging oscillatory behavior is far more likely in tightly tuned controllers where the user attempted to increase response too much.

When deciding on a PID control scheme, it is important to initially review all elements of the process. Sticking valves, undersized pumps, or delays in reaction times associated with chemical addition can have a dramatic effect on the stability of the control loop. When controlling a chemical mix or reaction, the sensor should be placed in a location that ensures proper mixing or reaction time has occurred.

The easiest process' to control with closed-loop schemes are generally linear, and symmetrical, in nature. For example, controlling level in tank where the opening of valve for a fixed period of time corresponds linearly to the amount that flows into a tank. Chemical control process' can be more problematic when the nature of the setpoint value is non-linear relative to the input of chemical added. For example, pH control of a process may appear linear only in a certain range of operation, and become highly exponential at the extreme ranges of the measuring scale. In addition, if a chemical process is not symmetrical, that means it responds differentially to the addition and subtraction of chemical. It is important in these applications to study steady-state impact as well as step-change impact to process changes. In other words, once the process has apparently been tuned under normal operating conditions, the user should attempt to force a dramatic change to the input to study how the output reacts. If this is difficult to do with the actual process input (the recommended method), the user can place the control in manual at an extreme control point such as 5% or 95%, and release it in manual. The recovery should not be overly oscillatory. If so, the loop needs to be de-tuned to deal with that condition (reduce P and/or I.)

Part 8 – System Maintenance

8.1 General

The Q46F/82 Auto-Chem Fluoride System requires regular maintenance for reliable operation. Keep in mind that preventive maintenance on a regular schedule is much less troublesome than emergency maintenance that always seems to come at the wrong time.

8.2 Analyzer Maintenance

No maintenance of the electronic monitor is required if installed according to the guidelines of this operating manual. During operation, it is best to use only your finger to operate front panel keys. Using tools, especially sharp objects, to press front panel keys will result in damage to the panel keys.

8.3 Sensor Maintenance

The primary maintenance for a fluoride sensor is to periodically add a small amount of electrolyte to the sensor. The body of the sensor is glass and it is easy to see the level of the internal solution. When it falls to about 60% full, add additional electrolyte using the pipette supplied with the sensor.

Over time, the response of the fluoride sensor can become sluggish or show excessive measurement drift due to adsorption of impurities on the face of the sensor. To clean the sensor of fats, oils and organics, gently rub the sensor tip with a cotton swab and ethyl alcohol. To remove inorganic residues, place the sensor tip in a 0.1 M HCl solution for 12 hours. Another recommended way to clean the sensor is using the polishing strip provided. Place the rougher side of the polishing strip facing up in the palm of your hand and put a few drops of distilled water on the strip. Press the face of the fluoride sensor onto the strip, rotating it back and forth to polish the fluoride crystal on the tip. Once polishing is done, rinse the face of the sensor with distilled water and then immerse the tip in a small amount of the 100 PPM fluoride standard for about 30 minutes.

Should the fluoride system be shut down for a length of time it will be necessary to remove the sensor, rinse the sensor with de-ionized water, dry the face of the sensor, and replace the protective cap. It is best to remove the internal filling solution as well, rinse with distilled water, and then empty out the distilled water. Long periods of time with the sensor sitting in stagnant water can result in sensor failure.

8.4 Sample Pump Tube Replacement

Peristaltic pump tubing replacement is the most common maintenance required for the Auto-Chem system. The sample pump used in this system contains two different tubes, one for the inlet (left) side of the pump and one for the outlet (right) side of the pump. **These tubes MUST be installed in the proper location or the system will not work.**

The inlet tube has a slightly smaller I.D. than the outlet tube. This is necessary to insure that the air stripping chamber does not fill with sample and force sample through the rest of the system.

The inlet tube is a yellow color and the outlet tube is black. Spare tubing is available in packages of 5, and spare tubes are cut to the proper length at the factory.

To replace the sample pump tubing, follow these steps.

1. Remove the reagent pickup assembly from the reagent bottle and place it in a container of tap water. Allow the monitor to run for 30 minutes. This will insure that all the buffer is out of the system prior to maintenance.
2. Release the front panel latch and tilt the front panel forward. Raise the lever on the fuse holder to turn off power to the chemistry system. Then, return the front panel to normal position.

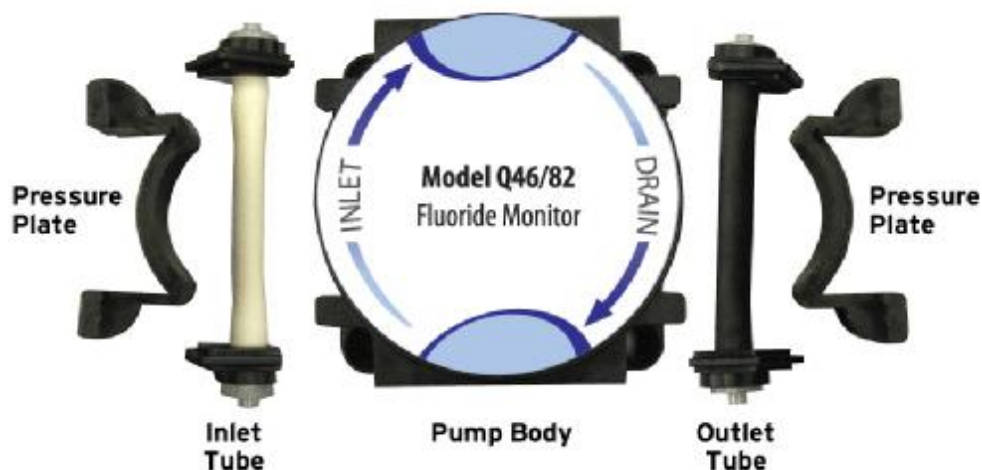

Figure 22 – Sample Pump Exploded View

3. Release the pressure plates on each side of the pump. This will allow sample and drain tubes to drain into the overflow. Then disconnect the inlet and outlet tubing connections from both sides of the pump.
4. Slide the tube holders out of the pump body and then pull the old tubes from barb end of the luer fittings.
5. Place one yellow tube and one black tube onto the two sets of fittings. Place the tube holders with the yellow tube onto the left side of the pump and place the tube holders with the black tube on the right side.
6. Once tube holders are in place, replace the pressure plates on each side of the pump.

8.5 Reagent Pump Tube Replacement

Replacement of the reagent pump tubes is similar to the procedure used for the sample pump. However, the replacement reagent tubes are supplied with the plastic tube fittings already attached. Do not pull the microbore tubing off of the fittings as it is difficult to put back on.

The reagent tubing assemblies snap into the tube holders at the middle of the plastic tube fittings. Observe the position of these assemblies prior to removing the old ones.

Part 9 – Troubleshooting

9.1 General

The information included in this section is intended to be used in an attempt to quickly resolve an operational problem with the system. During any troubleshooting process, it will save the most time if the operator can first determine if the problem is related to the analyzer, sensor, or some external source. Therefore, this section is organized from the approach of excluding any likely external sources, isolating the analyzer, and finally isolating the sensor. If these procedures still do not resolve the operational problems, any results the operator may have noted here will be very helpful when discussing the problem with the factory technical support group.

9.2 External Sources of Problems

To begin this process, review the connections of the system to all external connections.

1. Verify the analyzer is earth grounded. An earth ground connection **MUST** be present for the shielding systems in the electronics to be active. Grounded conduit provides no earth connection to the plastic enclosure, so an earth ground wiring connection must be made at the power input terminal strip.
2. Verify the proper power input is present (115/230 VAC).
3. Verify the loads on any 4-20 mA outputs do not exceed the limits in the Instrument Specifications. During troubleshooting, it is many times helpful to disconnect all these outputs and place wire-shorts across the terminals in the instrument to isolate the system and evaluate any problems which may be coming down the analog output connections.
4. Do not run sensor cables or analog output wiring in the same conduits as power wiring. If low voltage signal cables must come near power wiring, cross them at 90° to minimize coupling.
5. If rigid conduit has been run directly to the Q46 enclosure, check for signs that moisture has followed conduit into the enclosure.
6. Check for ground loops. Although the sensor is electrically isolated from the process, high frequency sources of electrical noise may still cause erratic behavior in extreme conditions.

7. On systems where relays are in use, check the relay load to verify the load is within the contact rating of the relays. Relay contacts which have been used for higher power AC current loads may become unsuitable for very low signal DC loads later on because a small amount of pitting can form on the contacts. If the load is highly inductive (solenoids, motor starters, large aux relays), note that the contact rating will be de-rated to a lower level. Also, due to the large amount of energy present in circuits driving these types of loads when they are switched on an off, the relay wiring placement can result in electrical interference for other devices. This can be quickly resolved by moving wiring, or by adding very inexpensive snubbers (such As Quencharcs) to the load.

9.3 Analyzer Tests

1. Disconnect power and completely disconnect all output wiring coming from the analyzer. Remove sensor wiring, relay wiring, and analog output wiring. Re-apply power to the analyzer.
2. Using the Simulate feature, check operation of analog outputs and relays with a DMM.
3. Check TC drive circuit. Place a wire-short between the GREEN and RED terminals. With a digital voltmeter (DVM), measure the voltage between the BLACK and GREEN terminals on the monitor to verify that the TC drive circuit is producing about 4.8-5.1 Vdc open circuit. Remove DVM completely and connect a 100 Ohm resistor from the BLACK to GREEN terminals. The temperature reading should display approximately 0°C.

9.4 Display Messages

The Q46 Series instruments provide a number of diagnostic messages which indicate problems during normal operation and calibration. These messages appear as prompts on the secondary line of the display or as items on the Fault List.

MESSAGE	DESCRIPTION	POSSIBLE CORRECTION
Max is 200	Entry failed, maximum user value allowed is 200.	Reduce value to ≤ 200
Min is 200	Entry failed, minimum value allowed is 200.	Increase value to ≥ 200
Cal Unstable	Calibration problem, data too unstable to calibrate. Icons will not stop flashing if data is too unstable. User can bypass by pressing ENTER.	Check to see that a stable standard is in use. If sample is stable, verify that sample from the drain tube is pH less than 4. Replace sensor is necessary
Out of Range	Input value is outside selected range of the specific list item being configured.	Check manual for limits of the function to be configured.
Locked!	Transmitter security setting is locked.	Enter security code to allow modifications to settings.
Unlocked!	Transmitter security has just been unlocked.	Displayed just after security code has been entered.
Offset High	The sensor zero offset point is out of the acceptable range.	Check wiring connections to sensor. Allow sensor to operate powered a minimum of 1 hour prior to first cal.
Sensor High	The raw signal from the sensor is too high and out of instrument range.	Check wiring connections to sensor. Be sure that the blue and white wires are not reversed.
Sensor Low	The raw signal from the sensor is too low.	Check wiring connections to sensor.
Fluoride High	The Fluoride reading is greater than the maximum of the User-selected range.	The reading is over operating limits. Set measuring range to the next highest level.
Cal Fail	Failure of fluoride calibration. FAIL icon will not extinguish until successful calibration has been performed, or 30 minutes passes with no keys being pressed.	Clean sensor redo calibration. If still failure, sensor slope may be less than 60% or greater than 120%. Replace sensor if failure recurs.
EPROM Fail	Internal nonvolatile memory failure	System failure, consult factory.
Chcksum Fail	Internal software storage error.	System failure, consult factory.
Display Fail	Internal display driver fail.	System failure, consult factory.
Range Cal Fail	Failure of factory temperature calibration.	Consult factory.

Figure 23 - Q46 Display Messages

Spare Parts

<u>Part No.</u>	<u>Description</u>
-----------------	--------------------

Q46 Electronic Assembly

03-0430	Q46F front lid assembly
07-0365	100-240 VAC monitor electronics assembly
07-0367	100-240 VAC monitor electronics assembly with Profibus
01-0306	Power supply circuit board assembly
23-0029	Fuse, 630mA, 250V, TR-5
38-0072	Terminal block plug, 3 position (relays)
38-0073	Terminal block plug, 4 position (outputs)
38-0074	Terminal block plug, 3 position (ground)
38-0081	Terminal block plug, 3 position (power)
31-0173	20 Pos. Ribbon cable
44-0311	Conduit entry plug, red PE
44-0274	Cord grip, 1/2" NPT

Auto-Chem Assembly

63-0108	Fluoride Sensor
31-0187	Sensor cable with BNC connector, 18"
00-1654	RTD Assembly, Pt100
03-0428	RTD wiring harness
03-0434	Pinch valve harness (pkg of 3)
03-0435	Drain pinch valve assy
03-0436	Calibration pinch valve assy
03-0437	Air Purge pinch valve assy
23-0002	Fuse, 2 A
03-0421	Sample pump assembly (requires parameter label)
03-0422	Reagent pump assembly
36-0051	Sample pump motor, 24 RPM
36-0049	Reagent pump motor, 6 RPM
03-0427	Pump motor wiring harness
03-0450	Standards Feed Tube Assy
05-0103	Sample pump inlet tubing, pkg. of 5
05-0104	Sample pump drain tubing, pkg. of 5
05-0102	Reagent pump tubing assembly, pkg. of 10
00-1652	24 VAC power supply, 115 VAC input
00-1657	24 VAC power supply, 230 VAC input
00-0055	12 VDC power supply, 100-240 VAC Input
45-0301	Acrylic Fluoride Sensor Flowblock
42-0024	Sensor Flowblock O-Ring

- 44-0114 3/32 x 1/16" Reducing Barb Fitting
- 44-0116 1/16" ID "Y" Barbed Fitting
- 03-0439 4-Way Bonded Fitting
- 31-0027 9-Conductor shielded cable

Tubing Fittings

- 44-0090 1/8" NPT x 1/4" I.D. right angle barb fitting
- 44-0159 Luer fitting, female, 1/8" barb
- 44-0164 Luer fitting, male, 1/8" barb
- 44-0167 1/8" NPT x 1/8" I.D. barb fitting
- 44-0184 Luer adapter, 1/8" NPT x male luer
- 44-0185 Luer cap, female
- 44-0253 Luer adapter, female, panel mount, 1/4-28 x 1/8" barb
- 44-0337 3/8" NPT x 1/2" I.D. barb fitting
- 44-0338 3/8" NPT plug
- 44-0438 Luer adapter, 5/32" tubing, 8 Scallops

Tubing

- 44-0007 Silicone tubing, 1/8" I.D. x 1/4" O.D.
- 44-0124 PTFE lined Tygon tubing 1/8" ID x 1/4" O.D.
- 44-0333 PVC tubing, 1/6" I.D. x 1/8" O.D.

Lock/Unlock Code: 1469