



CONTENTS

Scope of This Manual	3
Unpacking and Inspection	3
Safety	3
Terminology and Symbols.	3
Introduction.	3
Operating Principle	4
Installation.	4
Operational Startup	6
Troubleshooting Guide.	7
Specifications	8
Part Number Information	10
Strainer Part Numbers	10
Repair Kit Information	11

SCOPE OF THIS MANUAL

This manual is intended to help you get the QuikSert turbine flow meter up and running quickly.

IMPORTANT

Read this manual carefully before attempting any installation or operation. Keep the manual accessible for future reference.

UNPACKING AND INSPECTION

Upon opening the shipping container, visually inspect the product and applicable accessories for any physical damage such as scratches, loose or broken parts, or any other sign of damage that may have occurred during shipment.

NOTE: If damage is found, request an inspection by the carrier's agent within 48 hours of delivery and file a claim with the carrier. A claim for equipment damage in transit is the sole responsibility of the purchaser.

SAFETY

Terminology and Symbols



Indicates a hazardous situation, which, if not avoided, is estimated to be capable of causing death or serious personal injury.



Indicates a hazardous situation, which, if not avoided, could result in severe personal injury or death.



Indicates a hazardous situation, which, if not avoided, is estimated to be capable of causing minor or moderate personal injury or damage to property.

IMPORTANT

Not following instructions properly may impair safety of equipment and/or personnel.

INTRODUCTION

The QuikSert® explosion-proof turbine flow meter was developed for liquid applications where accuracy and dependability are of concern to the operator. QuikSert's stainless steel body incorporates a helical turbine with tungsten carbide shaft and bearings. It provides an efficient, long service life and a cost-effective solution for your measurement requirements.

Simple in design and construction, QuikSert uses modified upstream and downstream flow straighteners for a high degree of flow accuracy. Its between-the-flange design eliminates the need for mating flanges, requiring less space in the flow line, lowering costs and providing easy, one-man installation.

The meter produces a sine wave signal proportional to its volumetric flow rate. With optional Blancett electronics, QuikSert provides local flow rate and volume totalization and will interface with most instruments, PLCs and computers.

OPERATING PRINCIPLE

Fluid entering the meter passes through the inlet flow straightener which reduces its turbulent flow pattern and improves the fluid's velocity profile. Fluid then passes through the turbine, causing it to rotate at a speed proportional to the fluid velocity. As each turbine blade passes through the magnetic field, the blade generates an AC voltage pulse in the pickup coil at the base of the magnetic pickup (see *Figure 1*). These pulses produce an output frequency proportional to the volumetric flow through the meter. The output frequency represents flow rate and/or totalization of fluid passing through the turbine flow meter.

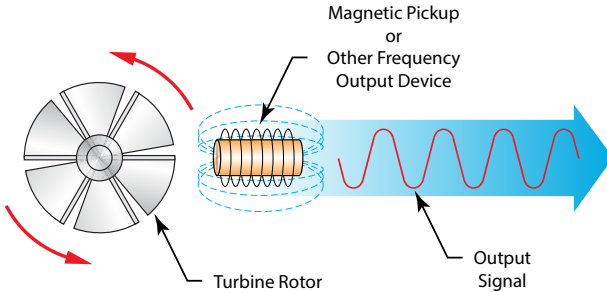

Figure 1: Schematic illustration of electric signal generated by rotor movement

INSTALLATION

Prior to installation, the flow meter should be checked internally for foreign material and to ensure the turbine rotor spins freely. Fluid lines should also be checked and cleared of all debris.

The flow meter must be installed with the flow arrow, etched on the exterior of the meter body, pointing in the direction of fluid flow. Though the meter is designed to function in any position, it is recommended, where possible, to install horizontally with the conduit adapter facing upward. Thread a magnetic pickup (Blancett model B111109 or equivalent) into the conduit adapter completely finger tight without forcing. Secure with a lock nut if supplied. Install conduit or other fittings suitable for the installation area onto the conduit adapter hub on the flow meter.

The liquid being measured should be free of any large particles that may obstruct rotation of the rotor. If particles are present, a mesh strainer should be installed upstream before operation of the flow meter.

The preferred plumbing setup is one containing a bypass line (*Figure 2 on page 5*) that allows meter inspection and repair without interrupting flow. If a bypass line is not used, it is important that all control valves be located downstream of the flow meter (*Figure 3 on page 5*).

⚠ WARNING

PRESSURE IN EXCESS OF ALLOWABLE RATING MAY CAUSE THE HOUSING TO BURST AND CAUSE SERIOUS PERSONAL INJURY.

CAUTION

DAMAGE CAN BE CAUSED BY STRIKING AN EMPTY METER WITH A HIGH VELOCITY FLOW STREAM.

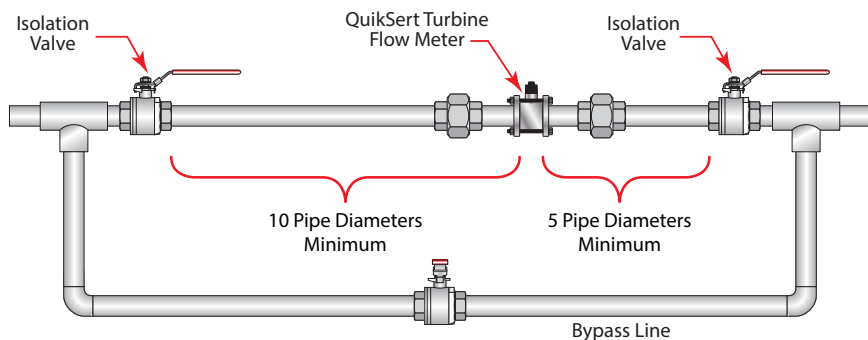

Figure 2: Meter installation using a bypass line

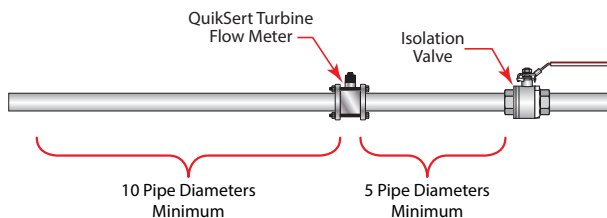

Figure 3: Meter installation without using a bypass line

This is true with any restriction in the flow line that may cause the liquid to flash. If necessary, air eliminators should be installed to ensure that the meter is not incorrectly measuring entrained air or gas.

It is recommended that a minimum length, equal to ten (10) pipe diameters of straight pipe, be installed on the upstream side and five (5) diameters on the downstream side of the flow meter. Otherwise, meter accuracy may be affected. Piping should be the same size as the meter bore or threaded port size.

Do not locate the flow meter or connection cable close to electric motors, transformers, sparking devices, high voltage lines, or place connecting cable in conduit with wires furnishing power for such devices. These devices can induce false signals in the flow meter coil or cable, causing the meter to read inaccurately.

If problems arise with the flow meter and monitor, consult *"Part Number Information"* on page 10. If further problems arise, consult the factory.

If the internal components of the turbine flow meter are damaged beyond repair, turbine meter repair kits are available. Information pertaining to the turbine meter repair kits is referenced in *"Repair Kit Information"* on page 11.

OPERATIONAL STARTUP

The following steps should be followed when installing and starting the meter.

⚠ WARNING

MAKE SURE THAT FLUID FLOW HAS BEEN SHUT OFF AND PRESSURE IN THE LINE RELEASED BEFORE ATTEMPTING TO INSTALL THE METER IN AN EXISTING SYSTEM.

1. After meter installation, close the isolation valves and open the bypass valve. Flow liquid through the bypass valve for sufficient time to eliminate any air or gas in the flow line.

⚠ CAUTION

HIGH VELOCITY AIR OR GAS MAY DAMAGE THE INTERNAL COMPONENTS OF THE METER.

2. Open upstream isolating valve slowly to eliminate hydraulic shock while charging the meter with the liquid. Open the valve to full open.
3. Open downstream isolating valve to permit meter to operate.
4. Close the bypass valve to a full closed position.
5. Adjust the downstream valve to provide the required flow rate through the meter.

NOTE: The downstream valve may be used as a control valve.

TROUBLESHOOTING GUIDE

Trouble	Possible Cause	Remedy
Meter indicates higher than actual flow rate	<ul style="list-style-type: none"> • Cavitation • Debris on rotor support • Build up of foreign material on meter bore • Gas in liquid 	<ul style="list-style-type: none"> • Increase back pressure • Clean meter • Clean meter • Install gas eliminator ahead of meter
Meter indicates lower than actual flow rate	<ul style="list-style-type: none"> • Debris on rotor • Worn bearing • Viscosity higher than calibrated 	<ul style="list-style-type: none"> • Clean meter and add filter • Clean meter and add filter • Recalibrate monitor
Erratic system indication, meter alone works well (remote monitor application only)	Ground loop in shielding	Ground shield one place only. Look for internal electronic instrument ground. Reroute cables away from electrical noise
Indicator shows flow when shut off	Mechanical vibration causes rotor to oscillate without turning	Isolate meter
No flow indication Full or partial open position	Fluid shock, full flow into dry meter or impact caused bearing separation or broken rotor shaft	Rebuild meter with repair kit and recalibrate monitor. Move to location where meter is full on startup or add downstream flow control valve
Erratic indication at low flow, good indication at high flow	Rotor has foreign material wrapped around it	Clean meter and add filter
No flow indication	Faulty pickup	Replace pickup
System works perfect, except indicates lower flow over entire range	Bypass flow, leak	Repair or replace bypass valves, or faulty solenoid valves
Meter indicating high flow, upstream piping at meter smaller than meter bore	Fluid jet impingement on rotor	Change piping
Opposite effects of above	Viscosity lower than calibrated	Change temperature, change fluid or recalibrate meter

SPECIFICATIONS

Materials of Construction	Body and Internal Wetted Parts	316 stainless steel					
	Rotor	CD4MCU stainless steel					
	Bearings	Tungsten carbide					
	Rotor Shaft	Tungsten carbide					
Operating Limitations	Temperature	-150...350° F (-101...177° C) The meter should not be subjected to temperatures above 350° F (177° C), or below -150° F (-101° C) or the freezing point of the metered liquid.					
	Pressure	Flange Rating (ANSI)	150#	300#	600#	900#	1500#
		Working Pressure (psi)	285	740	1480	2220	3705
		Working Pressure (MPa)	1.97	5.10	10.2	15.31	25.55
		*Test Pressure (psi)	427.5	1110	2220	3330	5557.5
		*Test Pressure (MPa)	2.95	7.65	15.31	22.96	38.32
*Test pressure based on 1.5 safety factor.							
Accuracy	± 1.0% of reading						
Repeatability	± 0.1%						
Calibration	Water (NIST Traceable Calibration)						
Pulsation and Vibration	Severe pulsation and mechanical vibration will affect accuracy and shorten the life of the meter						
Compliance	Class I Div. I Groups C,D Complies to UL1203 and CSA 22.2 No. 30 Met Labs File No. E112860						

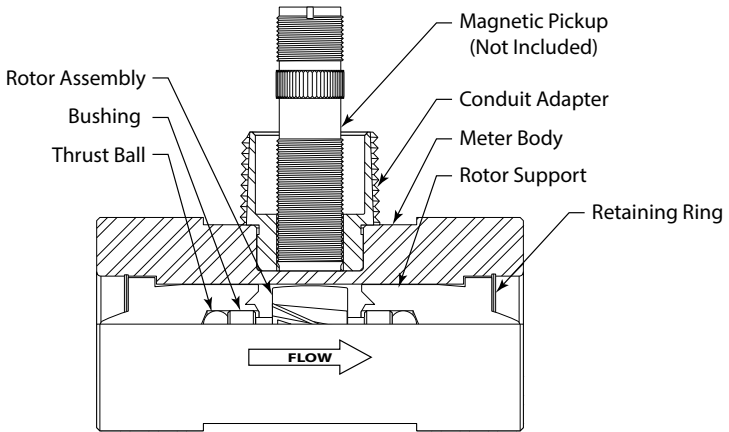

Figure 4: Typical cross-section of models B131C-038 through B131-100

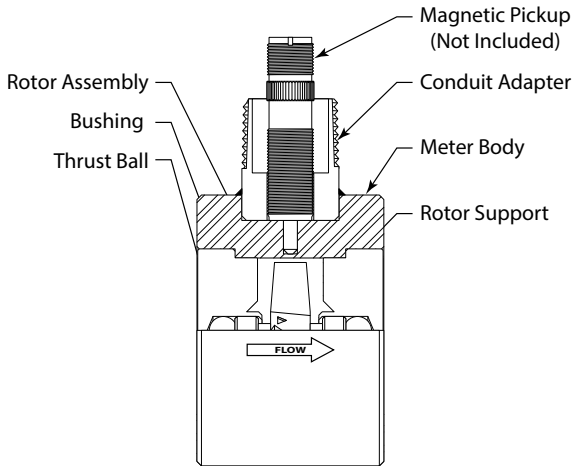

Figure 5: Typical cross-section of models B132C-050...B139C-900

PART NUMBER INFORMATION

Part Number	Meter Bore Size × Line Size	Flow Ranges		
		gpm	gpd	m ³ /D
B131C-038	3/8" × 1"	0.6...3	20...100	3.3...16
B131C-050	1/2" × 1"	0.75...7.5	25...250	4.1...41
B131C-075	3/4" × 1"	2...15	68...515	10.9...81.75
B131C-088	7/8" × 1"	3...30	100...1000	16...160
B131C-100	1" × 1"	5...50	170...1700	27.25...272.5
B132C-050	1/2" × 2"	0.75...7.5	25...250	4.1...41
B132C-075	3/4" × 2"	2...15	68...515	10.9...81.75
B132C-088	7/8" × 2"	3...30	100...1000	16...160
B132C-100	1" × 2"	5...50	170...1700	27.25...272.5
B132C-150	1-1/2" × 2"	15...180	515...6000	82...981
B132C-200	2" × 2"	40...400	1300...13,000	218...2180
B132C-250	2" × 3"	40...400	1300...13,000	218...2180
B133C-300	3" × 3"	60...600	2100...21,000	327...3270
B134C-400	4" × 4"	100...1200	3400...41,000	545...6540
B136C-600	6" × 6"	200...2500	6800...86,000	1090...13,626
B138C-800	8" × 8"	350...3500	12,000...120,000	1363...19,076
B139C-900	10" × 10"	500...5000	17,000...171,000	2725...27,252

Strainer Part Numbers

Part Number	Strainer Mesh	Clearance	Filter Size
B131C-038	60 × 60	0.0092	260 Micron
B131C-050	60 × 60	0.0092	260 Micron
B131C-075	60 × 60	0.0092	260 Micron
B131C-088	60 × 60	0.0092	260 Micron
B131C-100	60 × 60	0.0092	260 Micron
B132C-050	60 × 60	0.0092	260 Micron
B132C-075	60 × 60	0.0092	260 Micron
B132C-088	60 × 60	0.0092	260 Micron
B132C-100	40 × 40	0.0150	400 Micron
B132C-150	20 × 20	0.0340	0.86 mm
B132C-200	20 × 20	0.0650	0.86 mm
B132C-250	10 × 10	0.0900	1.6 mm
B133C-300	10 × 10	0.0900	1.6 mm
B134C-400	10 × 10	0.0650	1.6 mm
B136C-600	4 × 4	0.1875	4.8 mm
B138C-800	4 × 4	0.0900	4.8 mm
B139C-900	4 × 4	0.0900	4.8 mm

REPAIR KIT INFORMATION

Meter Bore Size × Line Size	Repair Kit Fits Meter Part Number	Repair Kit Part Number
3/8" × 1"	B131C-038	B253-102
1/2" × 1"	B131C-050	B253-105
3/4" × 1"	B131C-075	B253-108
7/8" × 1"	B131C-088	B253-109
1" × 1"	B131C-100	B253-112
1/2" × 2"	B132C-050	B253-205
3/4" × 2"	B132C-075	B253-208
7/8" × 2"	B132C-088	B253-209
1" × 2"	B132C-100	B253-212
1-1/2" × 2"	B132C-150	B253-216
2" × 2"	B132C-200	B253-220
2" × 3"	B132C-250	B253-220
3" × 3"	B133C-300	B253-330
4" × 4"	B134C-400	B253-440
6" × 6"	B136C-600	B253-660
8" × 8"	B138C-800	B253-880
10" × 10"	B139C-900	B253-990
Standard Magnetic Pickup	All Meter Sizes	B111109

Control. Manage. Optimize.

BLANCETT and QuikSert are registered trademarks of Badger Meter, Inc. Other trademarks appearing in this document are the property of their respective entities. Due to continuous research, product improvements and enhancements, Badger Meter reserves the right to change product or system specifications without notice, except to the extent an outstanding contractual obligation exists. © 2016 Badger Meter, Inc. All rights reserved.

www.badgermeter.com

The Americas | Badger Meter | 4545 West Brown Deer Rd | PO Box 245036 | Milwaukee, WI 53224-9536 | 800-876-3837 | 414-355-0400
México | Badger Meter de las Americas, S.A. de C.V. | Pedro Luis Ogazón N°32 | Esq. Angelina N°24 | Colonia Guadalupe Inn | CP 01050 | México, DF | México | +52-55-5662-0882
Europe, Middle East and Africa | Badger Meter Europa GmbH | Nürtinger Str 76 | 72639 Neuffen | Germany | +49-7025-9208-0
Europe, Middle East Branch Office | Badger Meter Europe | PO Box 341442 | Dubai Silicon Oasis, Head Quarter Building, Wing C, Office #C209 | Dubai / UAE | +971-4-371 2503
Czech Republic | Badger Meter Czech Republic s.r.o. | Maláčkova 2082/26 | 621 00 Brno, Czech Republic | +420-5-41420411
Slovakia | Badger Meter Slovakia s.r.o. | Racianska 109/B | 831 02 Bratislava, Slovakia | +421-2-44 63 83 01
Asia Pacific | Badger Meter | 80 Marine Parade Rd | 21-06 Parkway Parade | Singapore 449269 | +65-63464836
China | Badger Meter | 7-1202 | 99 Hangzhong Road | Minhang District | Shanghai | China 201101 | +86-21-5763 5412
Switzerland | Badger Meter Swiss AG | Mittelholzerstrasse 8 | 3006 Bern | Switzerland | +41-31-932 01 11