

# **Model Q45CT**

## **Toroidal Conductivity Monitor/Analyzer**

---

### **Home Office**

Analytical Technology, Inc.  
6 Iron Bridge Drive  
Collegeville, PA 19426

Ph: 800-959-0299  
610-917-0991  
Fax: 610-917-0992  
Email: [sales@analyticaltechnology.com](mailto:sales@analyticaltechnology.com)

### **European Office**

ATI (UK) Limited  
Unit 1 & 2 Gatehead Business Park  
Delph New Road, Delph  
Saddleworth OL3 5DE  
Ph: +44 (0)1457-873-318

Fax: + 44 (0)1457-874-468  
Email: [sales@atiuk.com](mailto:sales@atiuk.com)

---

## **PRODUCT WARRANTY**

Analytical Technology, Inc. (Manufacturer) warrants to the Customer that if any part(s) of the Manufacturer's products proves to be defective in materials or workmanship within the earlier of 18 months of the date of shipment or 12 months of the date of start-up, such defective parts will be repaired or replaced free of charge. Inspection and repairs to products thought to be defective within the warranty period will be completed at the Manufacturer's facilities in Collegeville, PA. Products on which warranty repairs are required shall be shipped freight prepaid to the Manufacturer. The product(s) will be returned freight prepaid and allowed if it is determined by the manufacturer that the part(s) failed due to defective materials or workmanship.

This warranty does not cover consumable items, batteries, or wear items subject to periodic replacement including lamps and fuses.

Gas sensors, except oxygen sensors, are covered by this warranty, but are subject to inspection for evidence of extended exposure to excessive gas concentrations. Should inspection indicate that sensors have been expended rather than failed prematurely, the warranty shall not apply.

The Manufacturer assumes no liability for consequential damages of any kind, and the buyer by acceptance of this equipment will assume all liability for the consequences of its use or misuse by the Customer, his employees, or others. A defect within the meaning of this warranty is any part of any piece of a Manufacturer's product which shall, when such part is capable of being renewed, repaired, or replaced, operate to condemn such piece of equipment.

This warranty is in lieu of all other warranties (including without limiting the generality of the foregoing warranties of merchantability and fitness for a particular purpose), guarantees, obligations or liabilities expressed or implied by the Manufacturer or its representatives and by statute or rule of law.

This warranty is void if the Manufacturer's product(s) has been subject to misuse or abuse, or has not been operated or stored in accordance with instructions, or if the serial number has been removed.

Analytical Technology, Inc. makes no other warranty expressed or implied except as stated above.

# Table of Contents

---

<b>TABLE OF FIGURES.....</b>	<b>4</b>	<b>PART 7 – PID CONTROLLER DETAILS.....</b>	<b>54</b>
<b>PART 1 - INTRODUCTION .....</b>	<b>5</b>	7.1 PID Description .....	54
1.1 General.....	5	7.2 PID Algorithm .....	54
1.2 Features.....	6	7.3 Classical PID Tuning .....	56
1.3 Q45CT System Specifications .....	8	7.4 Manual PID Override Control.....	57
1.4 Q45CT Performance Specifications.....	10	7.5 Common PID Pitfalls.....	57
<b>PART 2 – ANALYZER MOUNTING .....</b>	<b>11</b>	<b>PART 8 – SYSTEM MAINTENANCE.....</b>	<b>59</b>
2.1 General.....	11	8.1 System Checks.....	59
2.2 Wall or Pipe Mount.....	14	8.2 Instrument Checks .....	59
2.3 Panel Mount, AC Powered Monitor .....	16	8.3 Sensor Tests .....	60
<b>PART 3 – SENSOR MOUNTING.....</b>	<b>17</b>	8.4 Display Messages .....	61
3.1 General.....	17	<b>SPARE PARTS .....</b>	<b>63</b>
3.2 Tee Mounting.....	18		
3.3 Submersion Mounting.....	19		
<b>PART 4 – ELECTRICAL INSTALLATION.....</b>	<b>20</b>		
4.1 General.....	20		
4.2 Two-Wire.....	21		
4.2.1 Load Drive .....	23		
4.3 115/230 VAC w/Relays .....	23		
4.4 Sensor Wiring .....	26		
4.5 Direct Sensor Connection .....	26		
4.6 Sensor Junction Box .....	27		
<b>PART 5 – CONFIGURATION.....</b>	<b>29</b>		
5.1 User Interface.....	29		
5.1.1 Keys .....	30		
5.1.2 Display.....	30		
5.2 Software .....	32		
5.2.1 Software Navigation .....	32		
5.2.2 Measure Menu [MEASURE].....	36		
5.2.3 Calibration Menu [CAL].....	37		
5.2.4 Configuration Menu [CONFIG] .....	38		
5.2.5 Control Menu [CONTROL] .....	41		
5.2.6 Diagnostics Menu [DIAG].....	44		
<b>PART 6 – CALIBRATION .....</b>	<b>49</b>		
6.1 Overview and Methods .....	49		
6.1.1 1-Point Calibration Explained.....	49		
6.1.2 Zero Cal Calibration Explained .....	49		
6.2 Performing a Sensor Zero Calibration .....	50		
6.3 Performing a 1-Point Calibration.....	50		
6.4 Temperature Calibration .....	52		

# Table of Figures

---

<i>FIGURE 1 - Q45 ENCLOSURE DIMENSIONS, AC POWERED UNITS</i> .....	12
<i>FIGURE 2 - Q45 ENCLOSURE DIMENSIONS, 2-WIRE AND BATTERY UNITS</i> .....	13
<i>FIGURE 3 - WALL OR PIPE MOUNT BRACKET</i> .....	14
<i>FIGURE 4 - WALL MOUNTING DIAGRAM</i> .....	15
<i>FIGURE 5 - PIPE MOUNTING DIAGRAM</i> .....	15
<i>FIGURE 6 - 115/230 VAC PANEL MOUNT AND CUT-OUT</i> .....	16
<i>FIGURE 7 - SUBMERSIBLE SENSOR MOUNTING ASSEMBLY</i> .....	17
<i>FIGURE 8 - SENSOR MOUNTING - TEE ASSEMBLY</i> .....	18
<i>FIGURE 9 - SUBMERSIBLE SENSOR MOUNTING ASSEMBLY</i> .....	19
<i>FIGURE 10 - LOOP POWER CONNECTION, Q45CT TRANSMITTER</i> .....	22
<i>FIGURE 11 - LINE POWER CONNECTION</i> .....	25
<i>FIGURE 12 - RELAY CONTACTS</i> .....	26
<i>FIGURE 13 - SENSOR CABLE PREPARATION</i> .....	27
<i>FIGURE 14 - JUNCTION BOX WIRING</i> .....	28
<i>FIGURE 15 - USER INTERFACE</i> .....	29
<i>FIGURE 16 - SOFTWARE MAP</i> .....	34
<i>FIGURE 17 - CONTROL RELAY EXAMPLE</i> .....	43
<i>FIGURE 18 - ALARM RELAY EXAMPLE</i> .....	44
<i>FIGURE 19 - NaCl REFERENCE SOLUTION FOR CALIBRATION</i> .....	51
<i>FIGURE 20 - Q45CT (IDEAL) PID EQUATION</i> .....	55
<i>FIGURE 21 - PT1000 RTD TABLE</i> .....	60

# Part 1 - Introduction

---

## 1.1 General

The Model Q45CT Conductivity monitor/analyzer provides an extremely versatile measurement system for monitoring and control of conductivity over the range of 20  $\mu\text{S}/\text{cm}$  to 2.000 Siemen/cm. The instrument is offered standard as a loop-powered transmitter for 2-wire DC applications. Since this system configuration operates over only two low-voltage wires, it is ideal for remote monitoring applications where line power is either unavailable or prohibitively expensive to run.

With the optional 115/230 VAC power supply, the instrument may also be configured for AC operation. This configuration is ideal when line power is located close to the point of installation, and dual relay outputs and two 4-20 mA outputs (one for conductivity and one for temperature) are required.

An optional battery card is available that converts the instrument into a robust, portable measurement system that operates on one 9 VDC battery. In this configuration, all of the standard features of the basic 2-wire transmitter are functional with the exception that the instrument has two voltage outputs. The 9V unit is available either with or without a built-in data logger. Since this system utilizes the same high performance sensor as the standard configurations, it is a very robust portable monitoring system. It can be used on its own, or it can be used with other permanently installed Q45CT continuous monitoring systems to simplify calibration by using the calibrate-by-reference method.

In all configurations, the Q45CT displays conductivity on the main display, and total dissolved solids (TDS), sensor temperature, and output loop current on the secondary line of the custom display.

**WARNING:** Not following operating instructions may impair safety.

**NOTE:** Due to the high degree of flexibility of the Q45 system options, it is important to note areas of the operating manual that detail these optional features. The software features for the relay output option and battery option only appear when those modules are connected and the system has been re-powered.

## 1.2 Features

- Standard Q45CT electronic transmitters are designed to be a fully isolated, loop powered instruments for 2-wire DC applications. Optional integral power supply card for 115/230 VAC operation, and optional battery power supply card for portable datalogging applications are available.
- High accuracy, high sensitivity system, measures from 20 to 2,000,000  $\mu\text{S}$  through 7 internal automatic ranges. User display ranges include 2000  $\mu\text{S}$ , 2000 mS, 20.00 mS, or 200.0 mS, 2000 mS, or 2.000 S.
- Output Hold, Output Simulate, Output Alarm, and Output Delay Functions. All forced changes in output condition include bumpless transfer to provide gradual return to on-line signal levels and to avoid system control shocks on both analog outputs.
- AC power option provides dual SPDT relay operation and one additional isolated analog output. Software settings for relay control include setpoint, deadband, phase, delay, and failsafe. Software controls automatically appear in menu list when hardware option card is plugged in and system power is applied.
- Selectable PID controller on main analog output. PID controller can operate with instrument configured as loop-power transmitter, or as one of the two outputs on the AC powered instrument. PID includes manual operation feature, and diagnostic “stuck-controller” timer feature for relay notification of control problems.
- Configurable for TDS display and signal output on one analog output.
- Two analog outputs on the relay version may be configured to track conductivity and temperature, conductivity and conductivity, or conductivity and TDS. Both analog outputs can be individually programmed to fail to specific values.
- Selectable Output Fail Alarm feature on Relay B allows system diagnostic failures to be sent to external monitoring systems.
- Large, high contrast, custom Super-Twist display provides excellent readability even in low light conditions. The secondary line of display utilizes 5x7 dot matrix characters for clear message display. Two of the four measured parameters may be on the display simultaneously.

- Diagnostic messages provide a clear description of any problem with no confusing error codes to look up. Messages are also included for diagnosing calibration problems.
- Quick and easy one-point calibration method and sensor zero-cal. To provide high accuracy, all calibration methods include stability monitors that check temperature and main parameter stability before accepting data.
- High accuracy Pt1000 temperature input. Temperature element can be user calibrated.
- Security lock feature to prevent unauthorized tampering with transmitter settings. All settings can be viewed while locked, but they cannot be changed.
- High reliability, microprocessor-based system with non-volatile memory back-up that utilizes no batteries. Low mass, surface mount PCB construction containing no adjustment potentiometers. All factory calibrations stored in non-volatile EEPROM.

### 1.3 Q45CT System Specifications

#### (Common to all variations)

<b>Displayed Parameters</b>	Main input, 0 uS to 2S (2,000,000 uS) Sensor temperature, -10.0 to 210.0 °C (23 to 410 °F) Loop current, 4.00 to 20.00 mA Sensor slope Model number and software version PID Controller Status
<b>Main Parameter Ranges</b>	Automatic or Manual selection of one of the following display ranges, 0 to 2000 uS 0.0 to 2.000 mS 0.00 to 20.00 mS 0.0 to 200.0 mS 0 to 2000 mS 0.000 to 2.000 S
<b>Display</b>	Large, high-contrast, Super-Twist (STN) LCD; 4-digit main display with sign, 0.75" (19.1 mm) seven-segment characters 12-digit secondary display, 0.3" (7.6 mm) 5x7 dot matrix characters
<b>Keypad</b>	4-key membrane type with tactile feedback, polycarbonate with UV coating
<b>Weight</b>	DC transmitter configuration: 1 lb. (0.45 kg) Line powered unit: 1.5 lb. (0.68 kg)
<b>Ambient Temperature</b>	Analyzer Service, -20 to 60 °C (-4 to 140 °F) Storage, -30 to 70 °C (-22 to 158 °F)
<b>Ambient Humidity</b>	0 to 95%, indoor/outdoor use, non-condensing to rated ambient temperature range
<b>Electrical Certification</b>	Ordinary Location, cCSAus (CSA and UL standards - both approved by CSA), pollution degree 2, installation category 2
<b>EMI/RFI Influence</b>	Designed to EN 61326-1
<b>Output Isolation</b>	600 V galvanic isolation
<b>Filter</b>	Adjustable 0-9.9 minutes additional damping to 90% step input
<b>Temperature Input</b>	Pt1000 RTD with automatic compensation



<b>Sensor</b>	Fully isolated, toroidal electrode sensor design for direct measurement. 3/4" NPT process connection.
<b>Sensor Materials</b>	Noryl
<b>Sensor Pressure</b>	150 psig maximum
<b>Sensor Temperature</b>	Noryl, 0 to 105°C (32 to 221°F)
<b>Sensor Cable</b>	20 ft. (6.1 meter) 6-conductor cable. CPVC jacket rated to 105 °C dry and 70 °C wet.
<b>Max. Sensor-to-Analyzer Distance</b>	200 feet (61 meters), with special ATI junction box

**(NOT common to all variations)**

**Standard 2-Wire (Loop-powered) Transmitter:**

<b>Power</b>	18-35 VDC (2-wire device)
<b>Enclosure:</b>	NEMA 4X, polycarbonate, stainless steel hardware, weatherproof and corrosion resistant, HWD: 4.4" (112 mm) x 4.4" (112 mm) x 3.5" (89 mm)
<b>Mounting Options</b>	Wall or pipe mount bracket standard. Bracket suitable for either 1.5" or 2" I.D. U-Bolts for pipe mounting.
<b>Conduit Openings</b>	Two Pg-9 openings with gland seals, One 1" NPT opening with plug.
<b>DC Cable Type</b>	Belden twisted-pair, shielded, 22 gauge or larger
<b>Insertion Loss</b>	18 VDC

**115/230 VAC + Dual Relay Option:**

<b>Power</b>	115/230 VAC ± 10%, 50/60 Hz, 10 VA max
<b>Enclosure, AC Powered</b>	NEMA 4X, polycarbonate, stainless steel hardware, weatherproof and corrosion resistant, HWD: 4.9" (124 mm) x 4.9" (124 mm) x 5.5" (139 mm)
<b>Mounting Options</b>	Wall or pipe mount bracket standard. Bracket suitable for either 1.5" or 2" I.D. U-Bolts for pipe mounting. Panel mount adapter optional.
<b>Conduit Openings</b>	Three 1/2" NPT openings. Gland seals supplied but not installed.

**Relays, Electromechanical:** Two SPDT, 6 amp @ 250 VAC, 5 amp @ 24 VDC contacts. Software selection for setpoint, phase, delay, deadband, hi-lo alarm, and failsafe. A-B indicators on main LCD.

**Analog Outputs** Two 4-20 mA outputs. Output one programmable for conductivity or PID. Output 2 programmable for conductivity, temperature, or TDS. Max load 500 Ohms for each output. Outputs ground isolated and isolated from each other.

**1.4 Q45CT Performance Specifications**

**(Common to all variations)**

<b>Accuracy</b>	0.5% of user range, or better ( $\pm 2 \mu\text{S}$ )
<b>Repeatability</b>	0.2% of user range, or better ( $\pm 2 \mu\text{S}$ )
<b>Sensitivity</b>	0.05% of user ranges ( $\pm 2 \mu\text{S}$ )
<b>Stability</b>	0.2% of user range per 24 hours, non-cumulative
<b>Warm-up Time</b>	7 seconds to rated performance
<b>Supply Voltage Effects</b>	DC version only, $\pm 0.05\%$ of user range
<b>Instrument Response Time</b>	6 seconds to 90% of step input at lowest setting
<b>Temperature Drift</b>	Span or zero, 0.04% of span/ $^{\circ}\text{C}$



Equipment bearing this marking may not be discarded by traditional methods in the European community after August 12 2005 per EU Directive 2002/96/EC. End users must return old equipment to the manufacturer for proper disposal.

## Part 2 – Analyzer Mounting

---

### 2.1 General

All Q45 Series instruments offer maximum mounting flexibility. A bracket is included with each unit that allows mounting to walls or pipes. In all cases, choose a location that is readily accessible for calibrations. Also consider that it may be necessary to utilize a location where solutions can be used during the calibration process. To take full advantage of the high contrast display, mount the instrument in a location where the display can be viewed from various angles and long distances.

Locate the instrument in close proximity to the point of sensor installation - this will allow easy access during calibration. The standard cable length of the conductivity sensor is 20 feet. For sensor cables longer than 20 feet, use the optional junction box (07-0100) and sensor interconnect cable (31-0057).

Due to the flexibility of the instrument design, some of the mounting features change based on the configuration that was ordered. For example, the 2-wire transmitter version is different for the 115/230 VAC controller because the rear of the enclosure is much deeper when the AC powered unit is used. In addition, the AC powered unit has an integrated panel mount flange requiring a single cutout for flush mounting. In the 2-wire transmitter configuration, just the front of the enclosure can be mounted, but the cutout also requires accurate location of 4 mounting holes. Refer to Figure 1 and Figure 2 for detailed dimensions of each type of system.

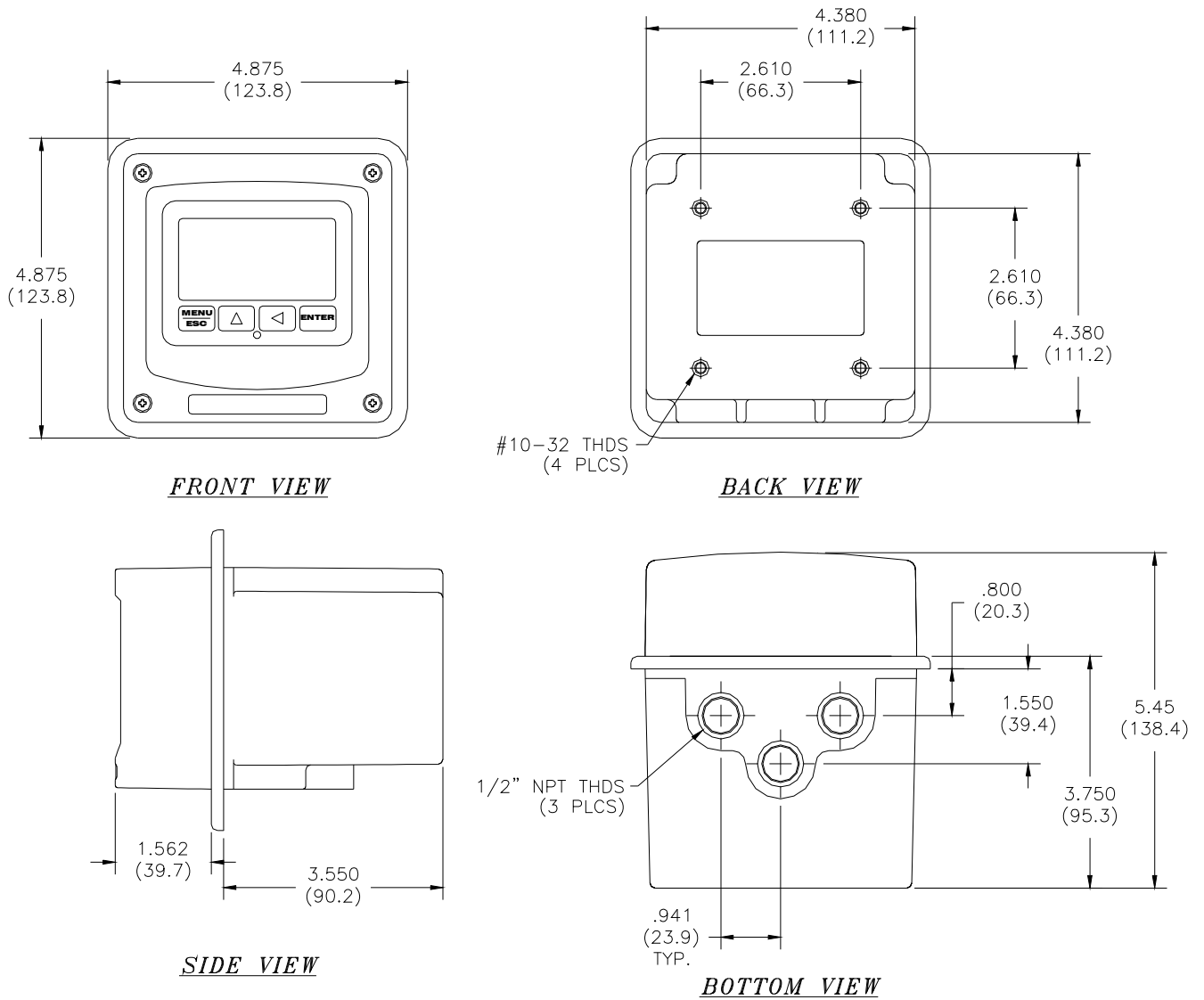
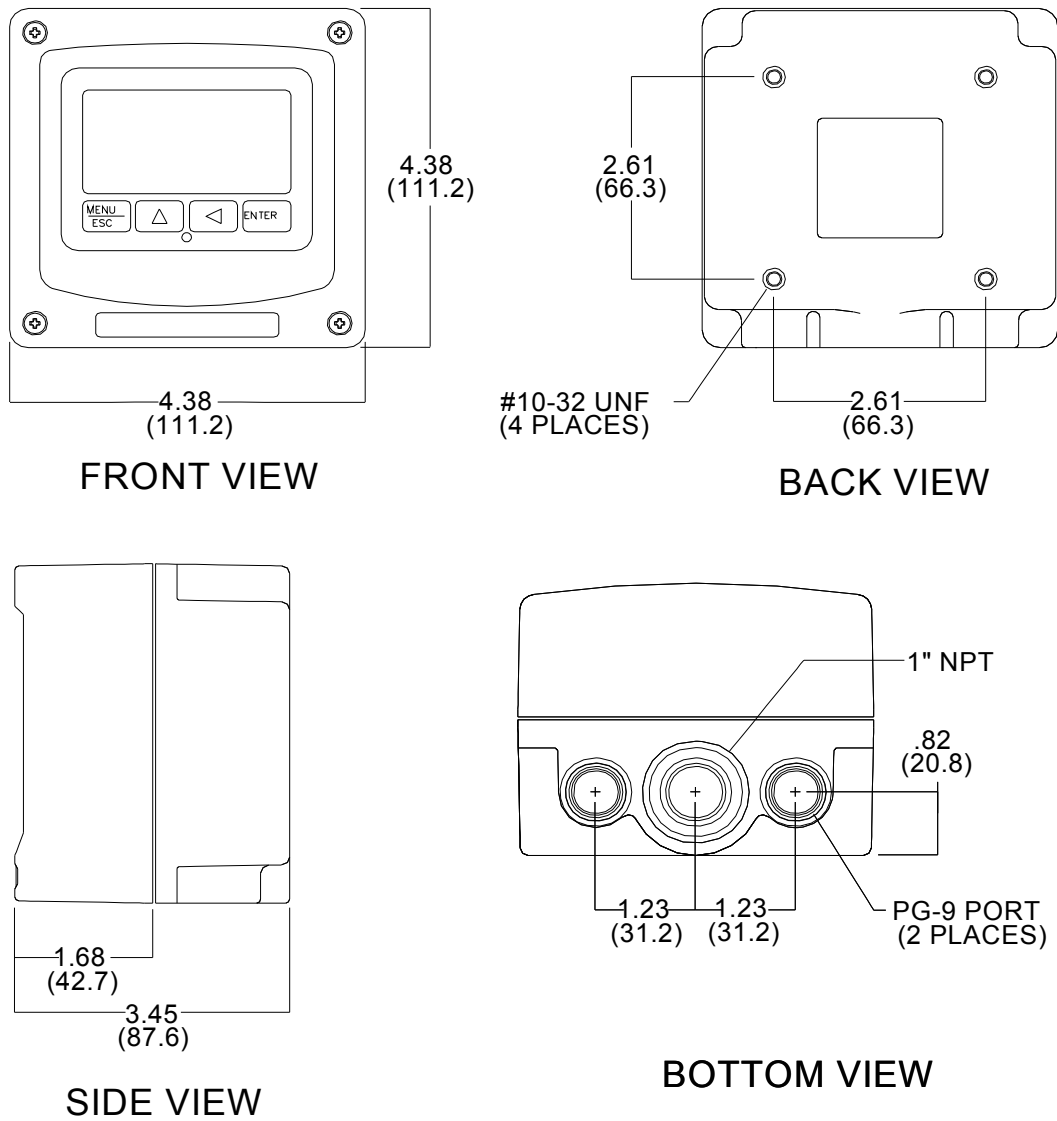


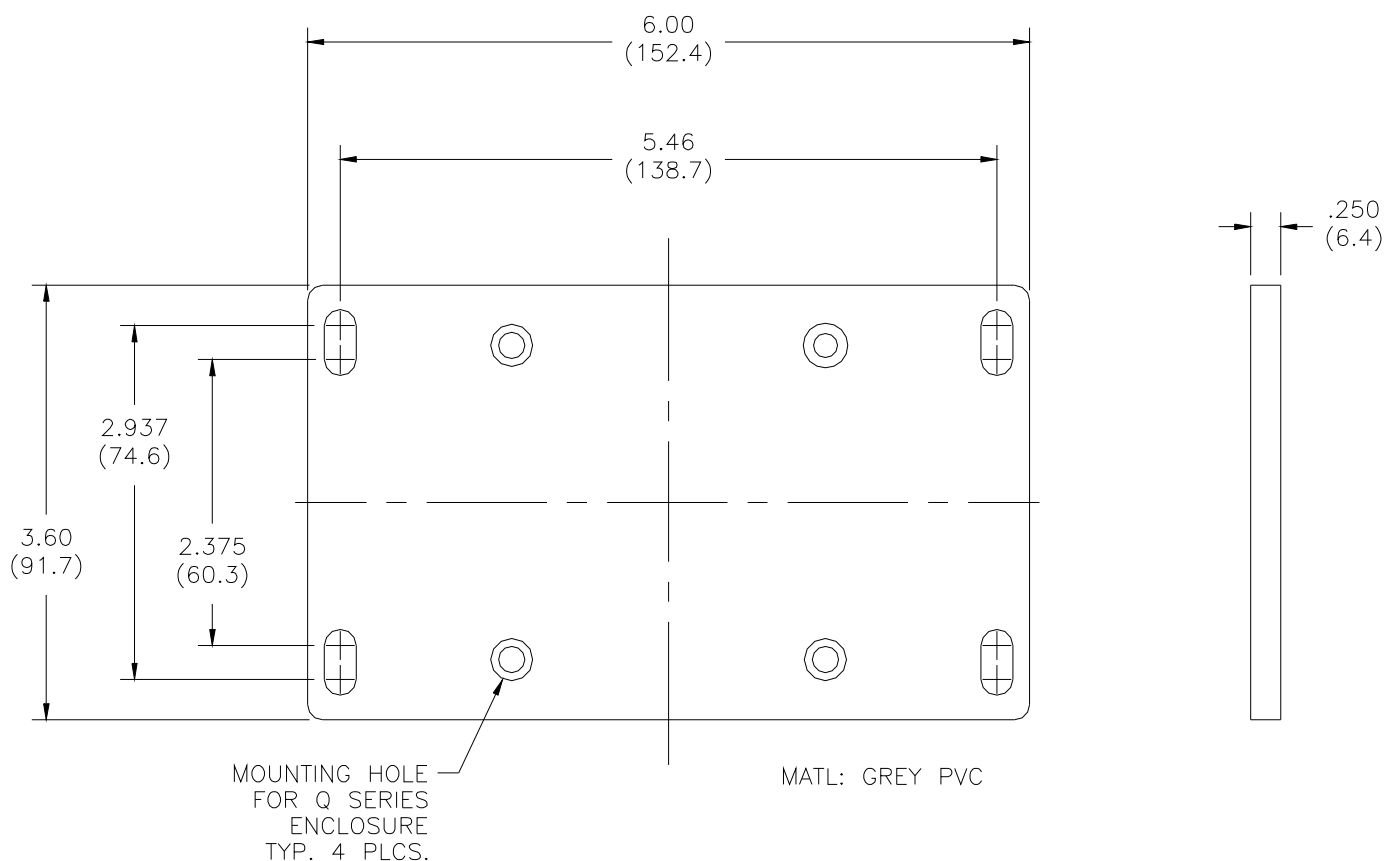
Figure 1 - Q45 Enclosure Dimensions, AC Powered Units



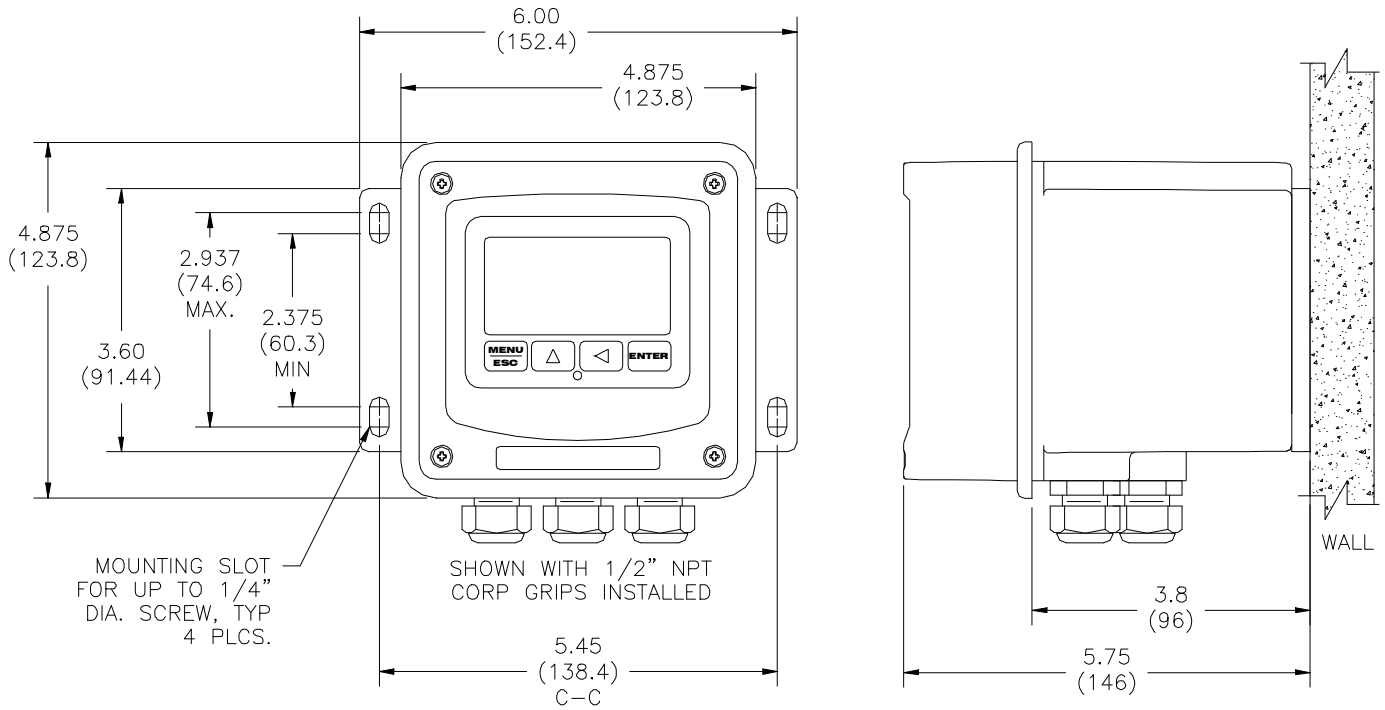
**Figure 2 - Q45 Enclosure Dimensions, 2-Wire and Battery Units**

## 2.2 Wall or Pipe Mount

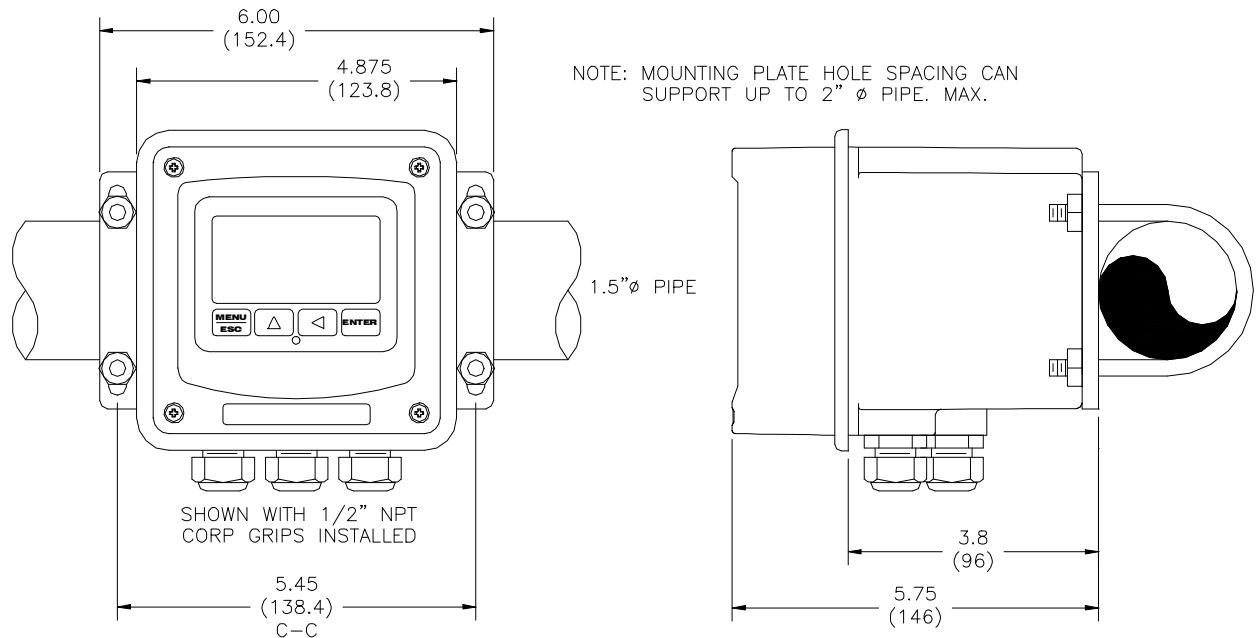
A PVC mounting bracket with attachment screws is supplied with each transmitter (see Figure 3 for dimensions). The multi-purpose bracket is attached to the rear of the enclosure using the four flat head screws. The instrument is then attached to the wall using the four outer mounting holes in the bracket. These holes are slotted to accommodate two sizes of u-bolt that may be used to pipe mount the unit. Slots will accommodate u-bolts designed for 1½” or 2” pipe. The actual center to center dimensions for the u-bolts are shown in the drawing. Note that these slots are for u-bolts with ¼-20 threads. The 1½” pipe u-bolt (2” I.D. clearance) is available from ATI in type 304 stainless steel under part number (47-0005)



**Figure 3 - Wall or Pipe Mount Bracket**



**Figure 4 - Wall Mounting Diagram**



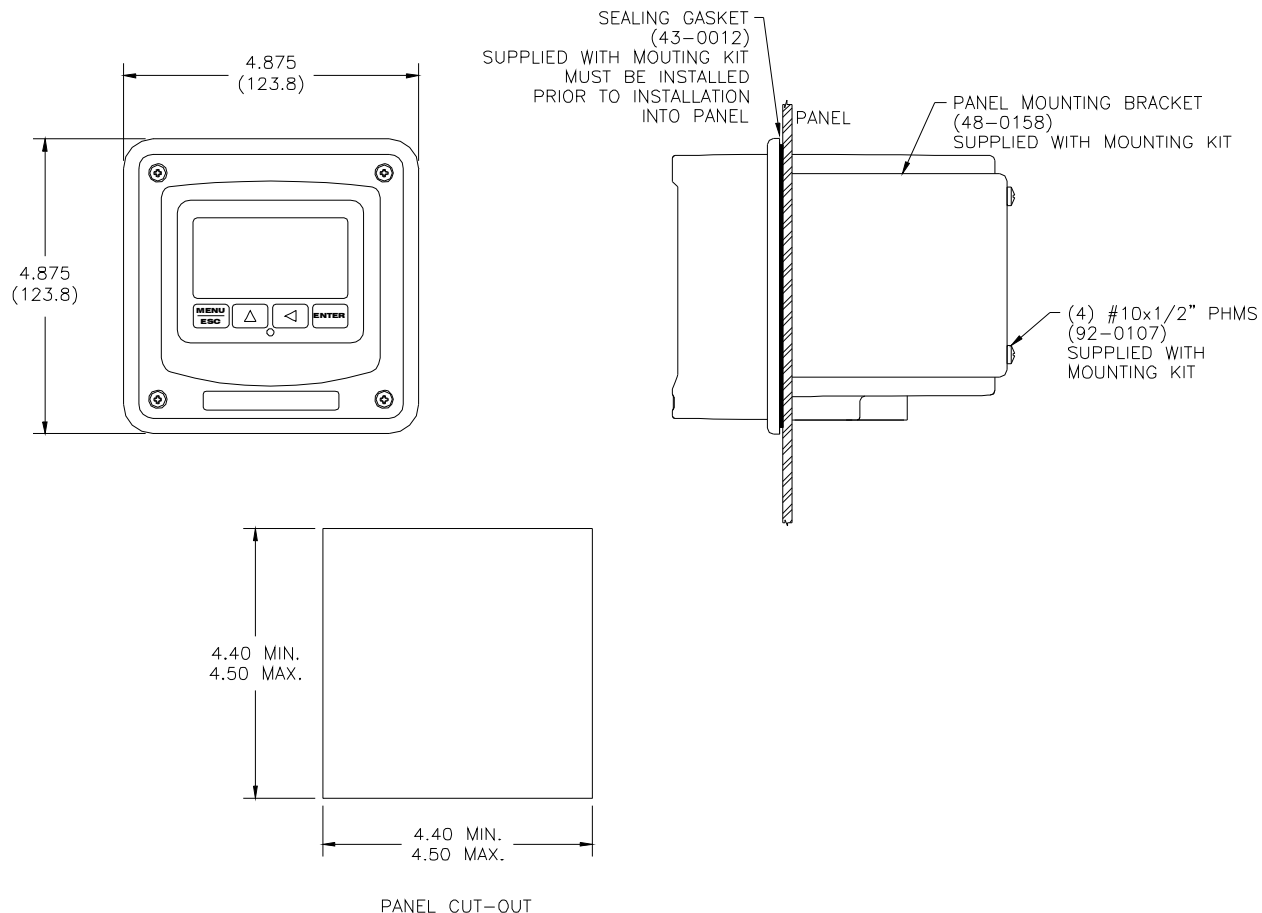
**Figure 5 - Pipe Mounting Diagram**

### 2.3 Panel Mount, AC Powered Monitor

Panel mounting of an AC powered monitor uses the panel mounting flange molded into the rear section of the enclosure. Figure 6 provides dimensions for the panel cutout required for mounting.

The panel mounting bracket kit (05-0068) must be ordered separately. This kit contains a metal retainer bracket that attaches to the rear of the enclosure, 4 screws for attachment of this bracket, and a sealing gasket to insure that the panel mounted monitor provides a water tight seal when mounted to a panel.

The sealing gasket must first be attached to the enclosure. The gasket contains an adhesive on one side so that it remains in place on the enclosure. Remove the protective paper from the adhesive side of the gasket and slide the gasket over the back of the enclosure so that the adhesive side lines up with the back of the enclosure flange. Once in place, you can proceed to mount the monitor in the panel.



**Figure 6 - 115/230 VAC Panel Mount and Cut-out**

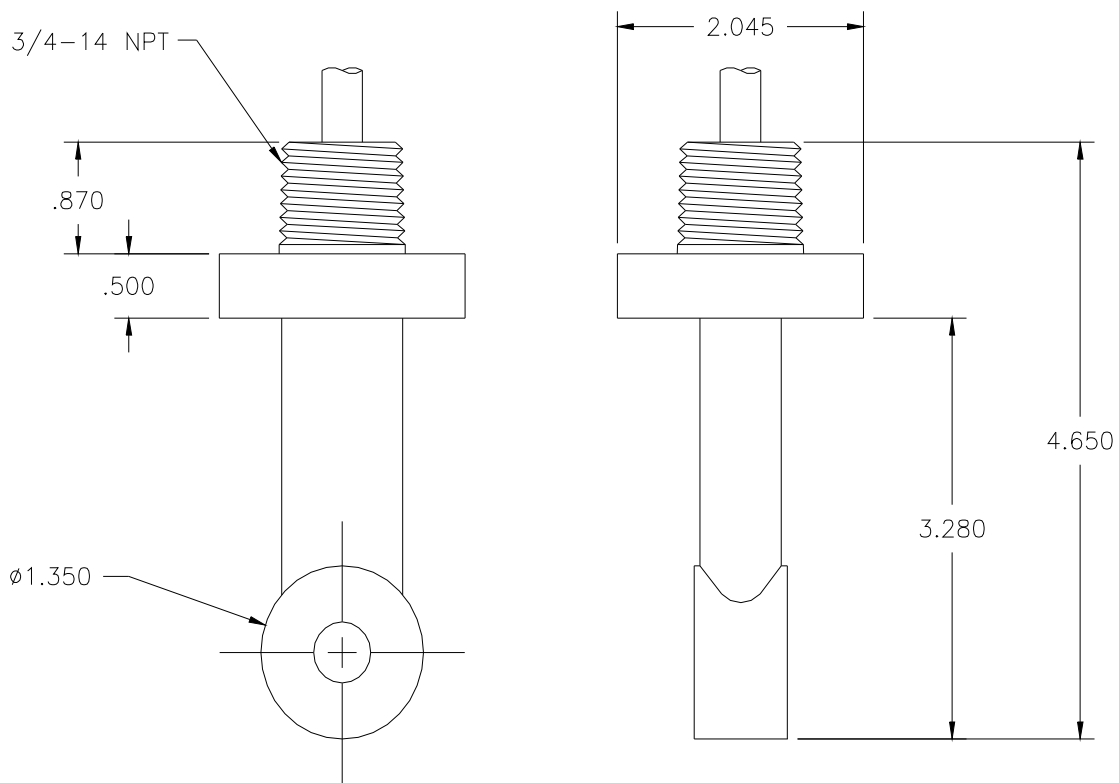


## Part 3 – Sensor Mounting

### 3.1 General

Select a location within the maximum sensor cable length for mounting of the sensor. In non-tee applications, it is recommended that the sensor face be kept at least 2" away from any nearby walls, pipes, etc. when mounted.

Figure 7, below, shows the dimensions and features of the toroidal sensor.

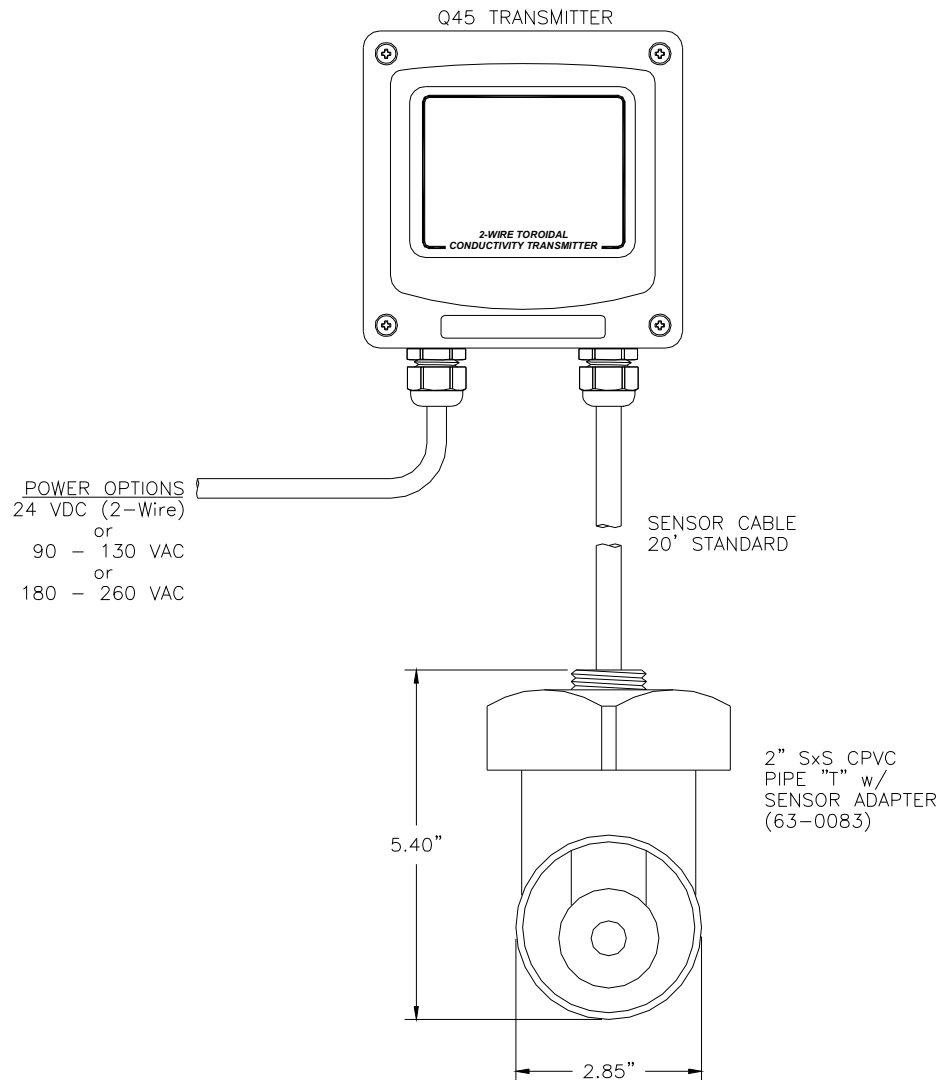


**Figure 7 - Submersible Sensor Mounting Assembly**

### 3.2 Tee Mounting

The toroidal sensors are mounted in a 2" pipe using an optional pipe adapter. The tee fitting is keyed so the sensor is oriented in the process as shown in Figure 8, below. The sensor bore opening should be aligned so that flow passes directly through the open sensor bore. A positioning notch is located on the upper sensor collar to aid in this alignment. This orientation is used to ensure a representative sample is being measured and to keep the sensor bore clean.

Note that sensor must be zero-calibrated before final mounting in tee.

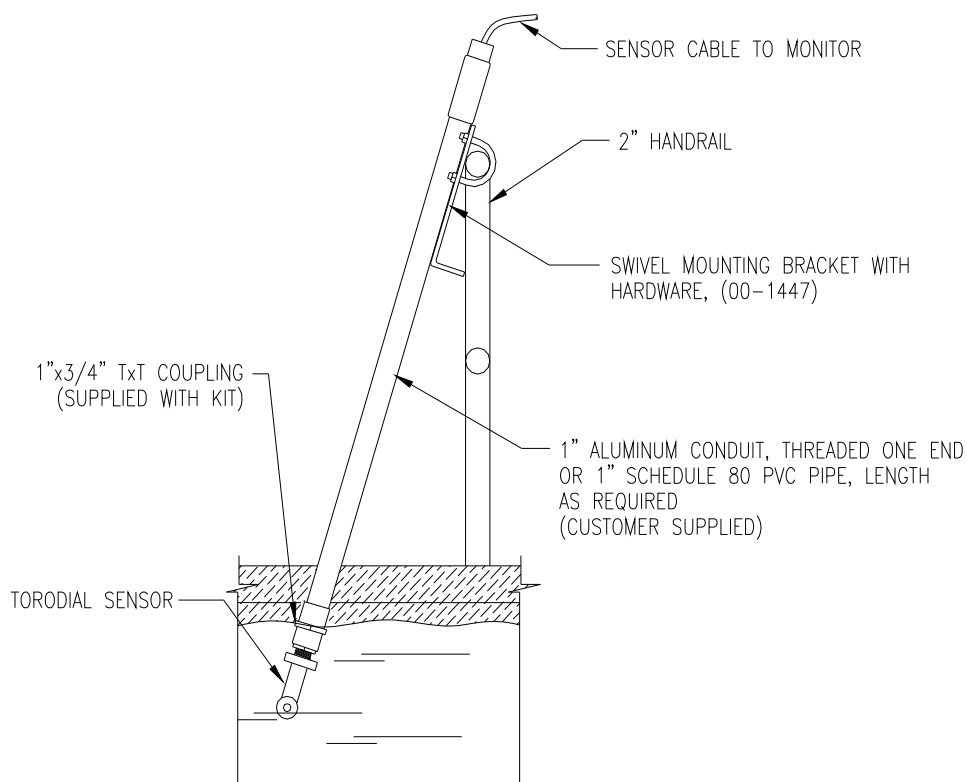


**Figure 8 - Sensor Mounting - Tee Assembly**

### 3.3 Submersion Mounting

Some applications are much easier done using the submersible sensor.

Submersible sensors are mounted to a 1" pipe using a standard 1" PVC thread by thread pipe coupling. The mounting pipe can be secured to standard 1½" pipe rail using a mounting bracket kit (00-0628) available from ATI, as shown in Figure 9. Maintain a minimum 2" distance from sensor face to any nearby walls, pipes, etc.



**Figure 9 - Submersible Sensor Mounting Assembly**

## Part 4 – Electrical Installation

---

### 4.1 General

The Q45 is powered in one of two ways, depending on the version purchased. The 2-wire version is a 18-35 VDC powered transmitter. The integral 115/230 VAC version requires line power. Please verify the type of unit before connecting any power.

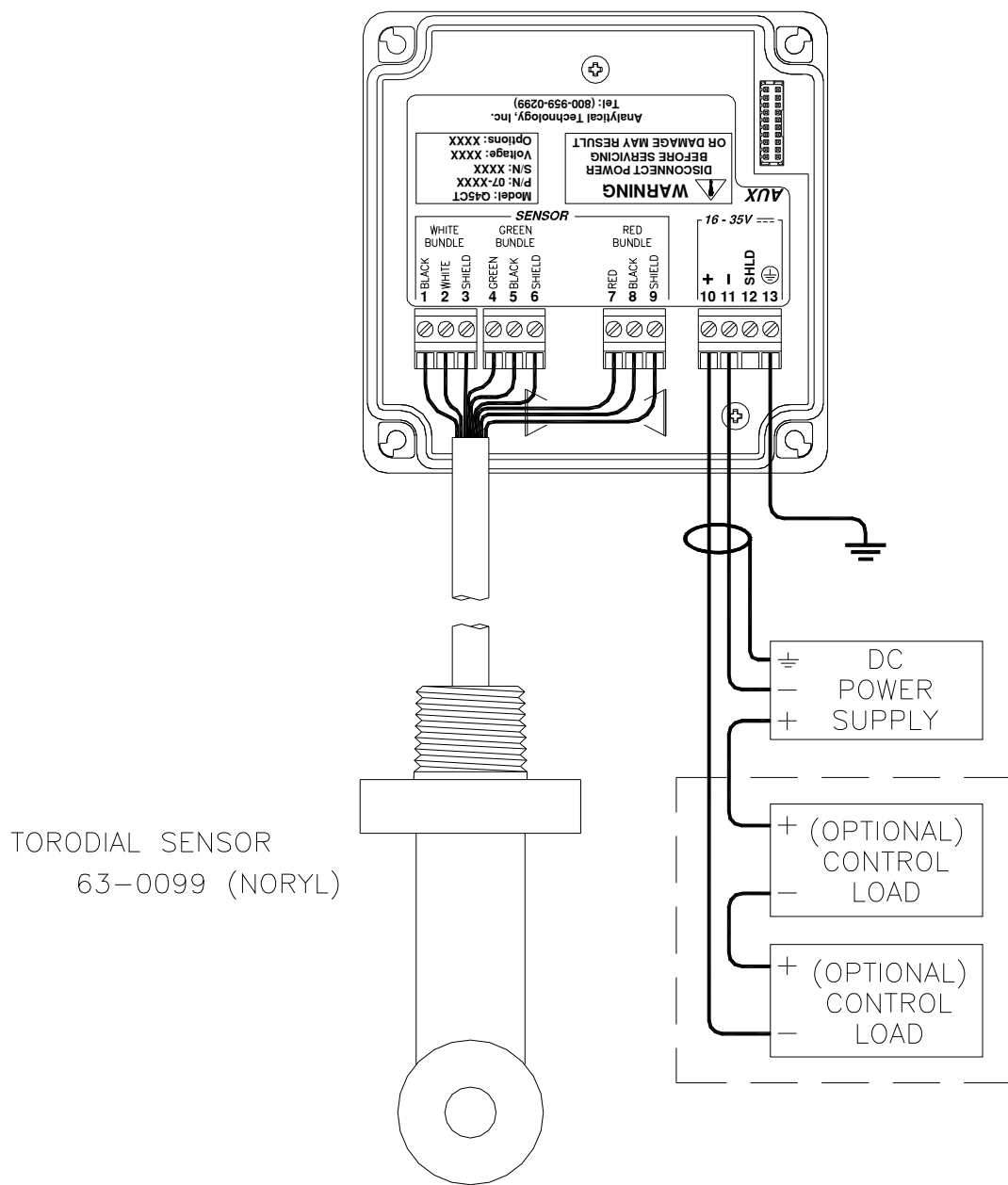
**WARNING: Do not connect AC line power to the 2-wire module. Severe damage will result.**

#### Important Notes:

1. Use wiring practices that conform to all national, state and local electrical codes. For proper safety as well as stable measuring performance, it is important that the earth ground connection be made to a solid ground point (Figure 10). The AC power supply contains a single 100mA (115V) or 50mA (230V) slo-blo fuse. The fuse **F1** is located adjacent to **TB5** and is easily replaceable.
2. Do NOT run sensor cables or instrument 4-20 mA output wiring in the same conduit that contains AC power wiring. AC power wiring should be run in a dedicated conduit to prevent electrical noise from coupling with the instrumentation signals.
3. This analyzer must be installed by specifically trained personnel in accordance with relevant local codes and instructions contained in this operating manual. Observe the analyzer's technical specifications and input ratings. Proper electrical disconnection means must be provided prior to the electrical power connected to this instrument, such as a circuit breaker - rated 250 VAC, 2 A minimum. If one line of the line power mains is not neutral, use a double-pole mains switch to disconnect the analyzer.

## 4.2 Two-Wire

In the two-wire configuration, a separate DC power supply must be used to power the instrument. The exact connection of this power supply is dependent on the control system into which the instrument will connect. See Figure 10 for further details. Any twisted pair shielded cable can be used for connection of the instrument to the power supply. Route signal cable away from AC power lines, adjustable frequency drives, motors, or other noisy electrical signal lines. Do not run sensor or signal cables in conduit that contains AC power lines or motor leads.



**Figure 10 - Loop Power Connection, Q45CT Transmitter**

- Notes:**
1. Voltage between Terminals 10 and 11 **MUST** be between 18 and 35 VDC.
  2. Earth ground into Terminal 13 is **HIGHLY** recommended. This connection can greatly improve stability in electrically noisy environments.

#### 4.21 Load Drive

The amount of resistance that the analog output can drive in the 115/230 VAC version is fixed. However, in the two-wire configuration, the load-drive level is dependent on the DC supply voltage provided to the controller.

The two-wire instrument can operate on a power supply voltage of between 18 and 35 VDC. The available load drive capability can be calculated by applying the formula  $V/I=R$ , where  $V$ =load drive voltage,  $I$ =maximum loop current (in Amperes), and  $R$ =maximum resistance load (in Ohms).

To find the load drive voltage of the two-wire Q45, subtract 18 VDC from the actual power supply voltage being used (the 18 VDC represents insertion loss). For example, if a 24 VDC power supply is being used, the load drive voltage is 6 VDC.

The maximum loop current of the two-wire Q45 is always 20.00 mA, or .02 A. Therefore,

$$\frac{(\text{Power Supply Voltage} - 18)}{.02} = R_{\text{MAX}}$$

For example, if the power supply voltage is 24 VDC, first subtract 18 VDC, and then divide the remainder by .02.  $6/.02 = 300$ ; therefore, a 300 Ohm maximum load can be inserted into the loop with a 24 VDC power supply.

Similarly, the following values can be calculated:

Power Supply Voltage (VDC)	Total Load (Ohms)
18.0	0
20.0	100
24.0	300
30.0	600
35.0	850

#### 4.3 115/230 VAC w/Relays

In the 115/230 VAC configuration, a DC power supply is mounted into the inside rear of the enclosure. The power supply must be ordered with the proper operating voltage. Verify that the unit requires either 115 VAC or 230 VAC before installing. Also verify that power is fully disconnected before attempting to wire.

AC powered Q45 systems are supplied with 3 cable gland fittings. One of the cable glands has a larger hole in the rubber gland and should be used for the power cord entry if a flexible power cord will be used for installation. One of the cable glands with the smaller gland opening should normally be used for the sensor cable. Cable glands will screw into any of the three threaded holes on the bottom of the enclosure.

Connect HOT, NEUTRAL, and GROUND to the matching designations on terminal strip **TB5**.

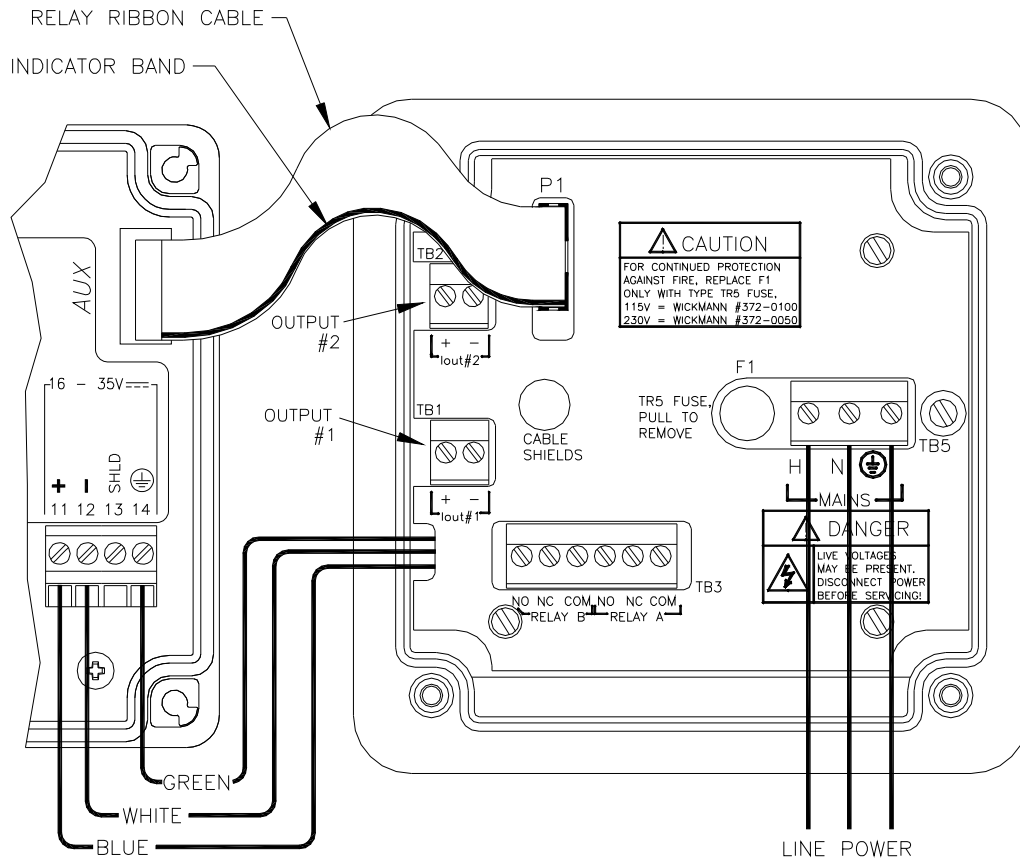
## WARNING

**Disconnect line power voltage BEFORE connecting line power wires to Terminal TB5 of the power supply. The power supply accepts only standard three-wire single phase power. The power supply is configured for 115 VAC or 230 VAC operation at the factory at time of order, and the power supply is labeled as such. Do NOT connect voltages other than the labeled requirement to the input.**

The analog outputs from the system are present at terminals TB1 and TB2. The loop-load limitation in this configuration is 500 Ohms maximum for each output. Also note that these two outputs are completely isolated from each other to insure that ground loops do not result from the connection of both outputs to the same device such as a PLC or DCS.

In the line-powered unit, a ribbon cable connects the power supply assembly with the microprocessor assembly located in the front section of the enclosure. This cable can be removed during installation to facilitate wiring if desired. It is best to unplug only one end. The ribbon cable has a marking stripe on one edge that is used to indicate proper orientation. The indicator stripe should be on the bottom edge of the cable when installed as shown in Figure 11.

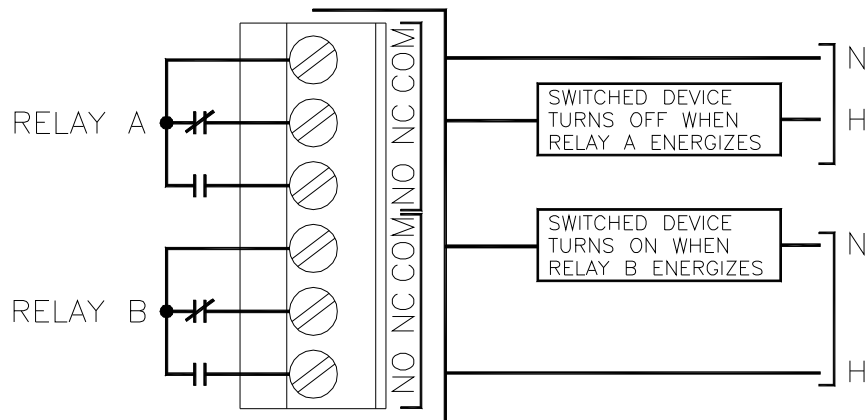




**Figure 11 - Line Power Connection**

The power strip, **TB5**, allows up to 12 AWG wire. A wire gauge of 16 AWG is recommended to allow for an easy pass-through into the ½” NPT ports when wiring.

Two sets of SPDT relay contacts are provided on the power supply board. None of the relay contacts are powered. The user must supply the proper power to the contacts. For applications that require the same switched operating voltage as the Q45 (115 or 230 V), power may be jumpered from the power input terminals at **TB5**. Relay wiring is connected at **TB3** as shown below. Note that the relay contact markings are shown in the NORMAL mode. Programming a relay for “Failsafe” operation reverses the NO and NC positions in this diagram.



**Figure 12 - Relay Contacts**

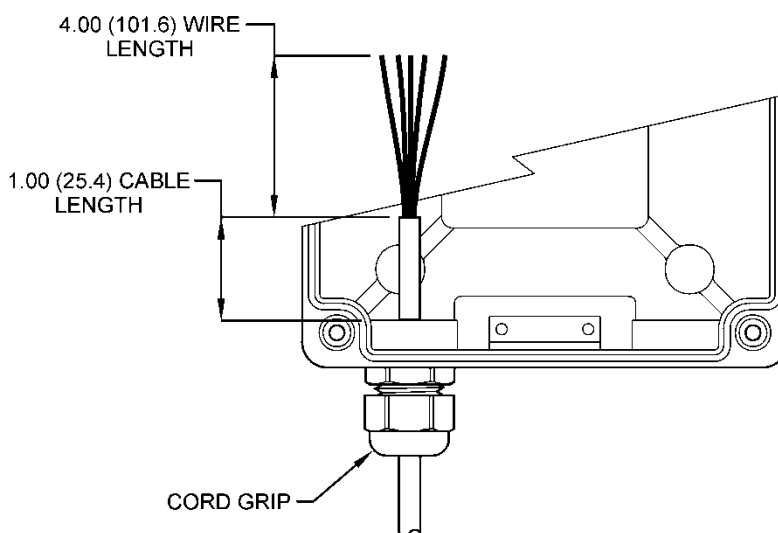
#### 4.4 Sensor Wiring

The sensor cable can be quickly connected to the Q45 terminal strip by matching the wire colors on the cable to the color designations on the label in the monitor. A junction box is also available to provide a break point for long sensor cable runs. Route signal cable away from AC power lines, adjustable frequency drives, motors, or other noisy electrical signal lines. Do not run sensor or signal cables in conduit that contains AC power lines or motor leads.

#### 4.5 Direct Sensor Connection

Sensor connections are made in accordance with Figure 10. The sensor cable can be routed into the enclosure through one of cord-grips supplied with the unit. Routing sensor wiring through conduit is only recommended if a junction box is to be used. Some loose cable is needed near the installation point so that the sensor can be inserted and removed easily from the flowcell.

Cord-grips used for sealing the cable should be snugly tightened after electrical connections have been made to prevent moisture incursion. When stripping cables, leave adequate length for connections in the transmitter enclosure as shown below. The standard 20 ft. sensor cable normally supplied with the system is already stripped and ready for wiring. This cable can be cut to a shorter length if desired to remove extra cable in a given installation. Do not cut the cable so short as to make installation and removal of the sensor difficult.

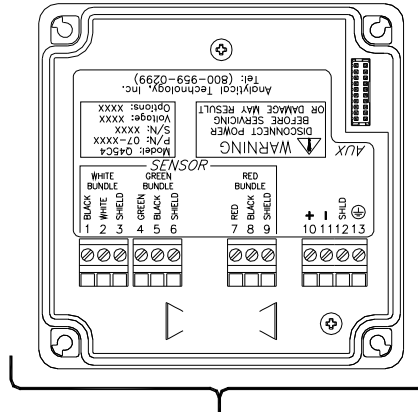


**Figure 13 - Sensor Cable Preparation**

#### 4.6 Sensor Junction Box

When sensor separation from the monitor is needed and to be greater than 20 feet, the sensor junction box is required (07-0100). Wire according to Figure 14 with 3 paired, individually shielded 22 AWG cable (31-0068).

**CAUTION:** When using a junction box and sensor interconnect cable, the **RED SHIELD** must be isolated from the **WHITE** and **GREEN SHIELDS**. Failure to maintain isolation with the **RED SHIELD** will result in measurement instability.



22 AWG 3 PAIRED INDIVIDUALLY SHIELDED CABLE REQD. BELDEN # 8777 or (31-0068)

CUSTOMER MUST FOLLOW CONTINUITY FROM J-BOX TO MONITOR, WHEN CONNECTING CABLE

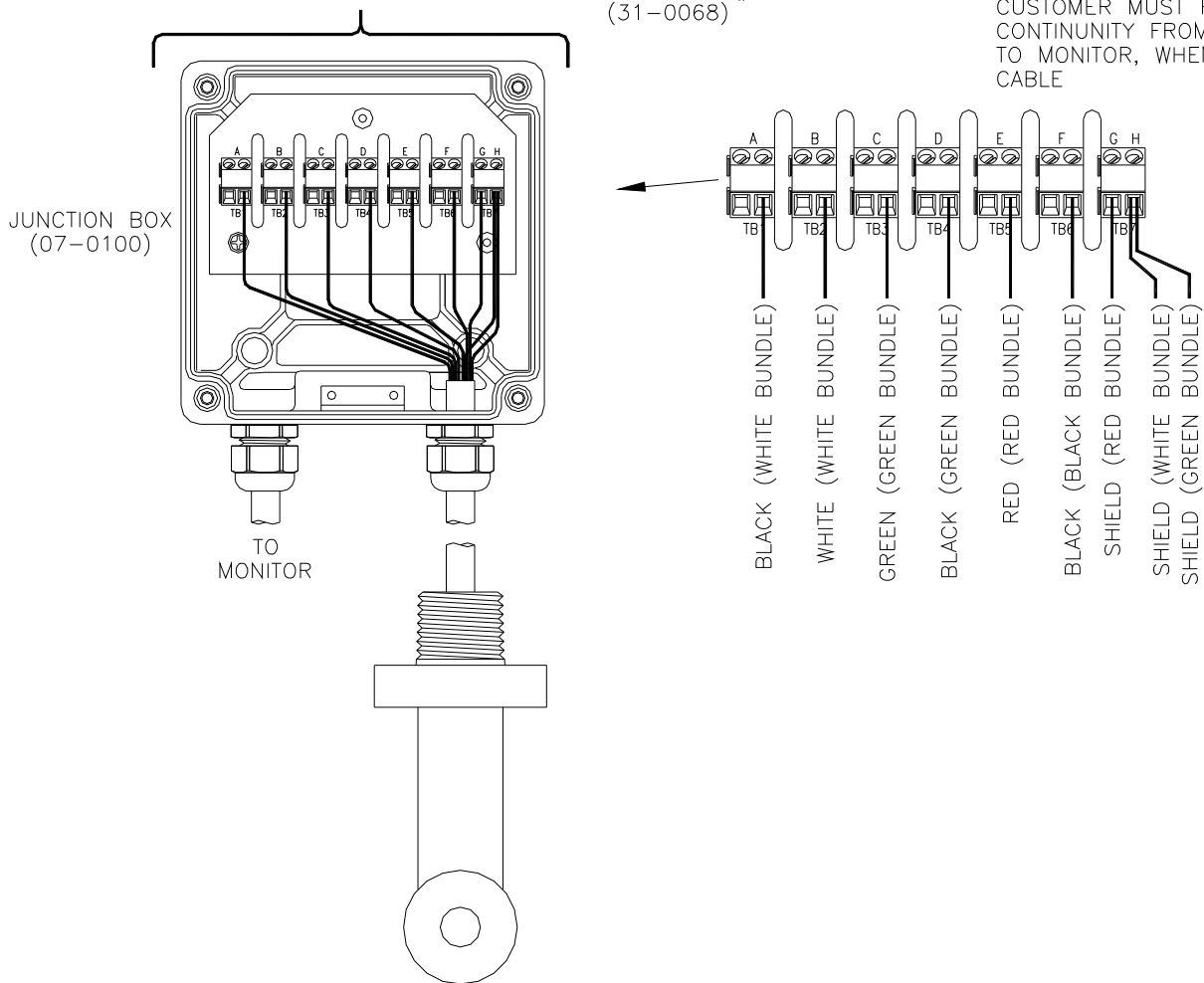
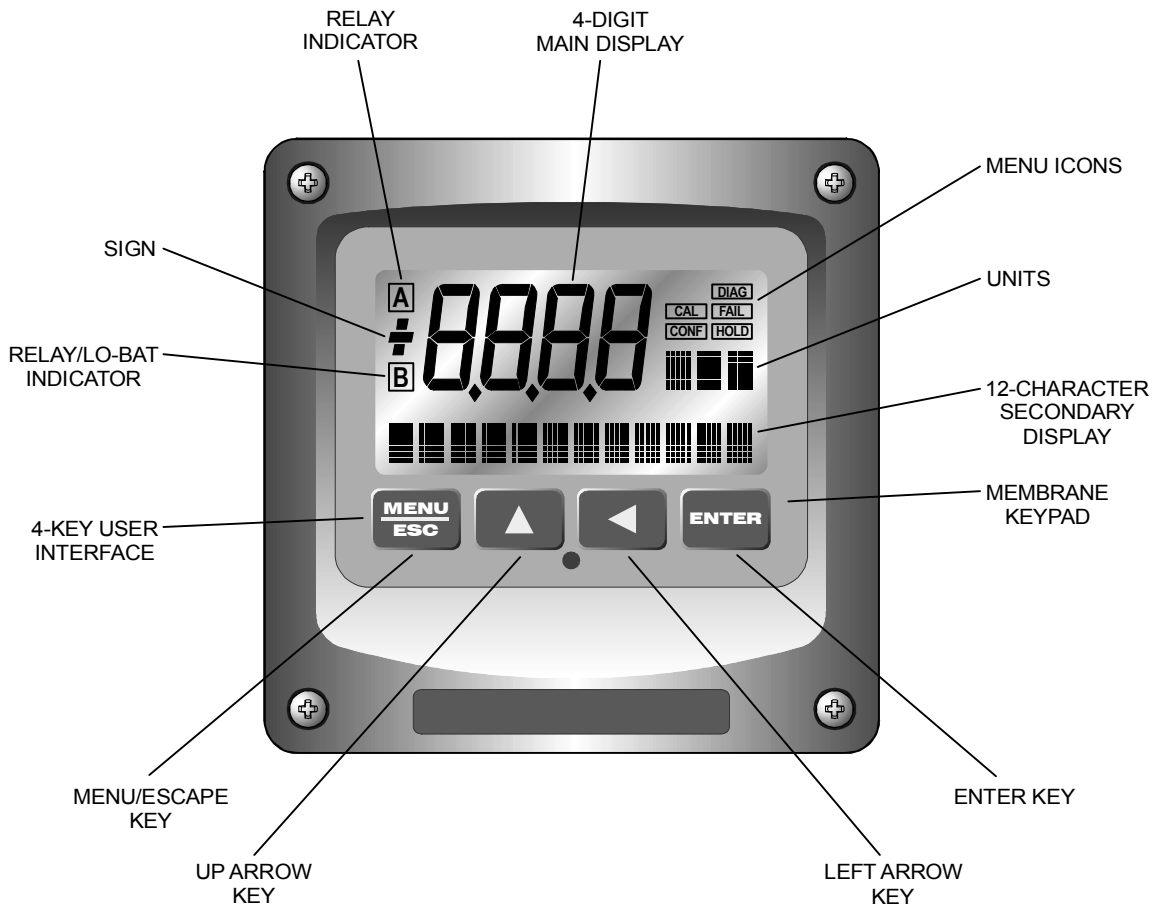


Figure 14 - Junction Box Wiring

# Part 5 – Configuration

## 5.1 User Interface

The user interface for the Q45 Series instrument consists of a custom display and a membrane keypad. All functions are accessed from this user interface (no internal jumpers, pots, etc.).



**Figure 15 - User Interface**

## 5.11 Keys

All user configurations occur through the use of four membrane keys. These keys are used as follows:

- |                     |   |
|---------------------|---|
| <b>MENU/ESC</b>     | To scroll through the menu section headers or to escape from anywhere in software. The escape sequence allows the user to back out of any changes in a logical manner. Using the escape key aborts all changes to the current screen and backs the user out one level in the software tree. The manual will refer to this key as either MENU or ESC, depending upon its particular function. In the battery-powered version of the Q45, this is also the ON button. |
| <b>UP (arrow)</b>   | To scroll through individual list or display items and to change number values.   |
| <b>LEFT (arrow)</b> | To move the cursor from right to left during changes to a number value.   |
| <b>ENTER</b>        | To select a menu section or list item for change and to store any change.   |

## 5.12 Display

The large custom display provides clear information for general measurement use and user configuration. There are three main areas of the display: the main parameter display, the secondary message line, and the icon area.

**Main Parameter** During normal operation, the main parameter display indicates the present process input with sign and units. This main display may be configured to display any of the main measurements that the system provides. During configuration, this area displays other useful set-up information to the user.



**Lower Line**

During normal operation, the lower line of the display indicates user-selected secondary measurements that the system is making. This also includes calibration data from the last calibration sequence and the transmitter model number and software version. During configuration, the lower line displays menu items and set-up prompts to the user. Finally, the lower line will display error messages when necessary. For a description of all display messages, refer to Section 8.4.

**Icon Area**

The icon area contains display icons that assist the user in set-up and indicate important states of system functions. The CAL, CONFIG, CNTRL, and DIAG icons are used to tell the user what branch of the software tree the user is in while scrolling through the menu items. This improves software map navigation dramatically. Upon entry into a menu, the title is displayed (such as CAL), and then the title disappears to make way for the actual menu item. However, the icon stays on.

**HOLD**

The HOLD icon indicates that the current output of the transmitter has been put into output hold. In this case, the output is locked to the last input value measured when the HOLD function was entered. HOLD values are retained even if the unit power is cycled.

**FAIL**

The FAIL icon indicates that the system diagnostic function has detected a problem that requires immediate attention. This icon is automatically cleared once the problem has been resolved.

## Relay Area A/B

The relay area contains two icons that indicate the state of the system relays (if the relay card is installed). If the battery board is installed instead, the B icon indicates that the battery voltage is at a low level. The battery power option and the relay option cannot be installed together.



## 5.2 Software

The software of the Q45CT is organized in an easy to follow menu-based system. All user settings are organized under five menu sections: Measure, Calibration [CAL], Configuration [CONFIG], Control [CONTROL] and Diagnostics [DIAG].

**Note: The default Measure Menu is display-only and has no menu icon.**

### 5.2.1 Software Navigation

Within the CAL, CONFIG, CONTROL, and DIAG menu sections is a list of selectable items. Once a menu section (such as CONFIG) has been selected with the MENU key, the user can access the item list in this section by pressing either the ENTER key or the UP arrow key. The list items can then be scrolled through using the UP arrow key. Once the last item is reached, the list wraps around and the first list item is shown again. The items in the menu sections are organized such that more frequently used functions are first, while more permanent function settings are later in the list. See Figure 16 for a visual description of the software.

Each list item allows a change to a stored system variable. List items are designed in one of two forms: simple single variable, or multiple variable sequence. In the single variable format, the user can quickly modify one parameter - for example, changing temperature display units from °F to °C. In the multiple variable sequence, variables are changed as the result of some process. For example, the calibration of conductivity generally requires more than one piece of information to be entered. The majority of the menu items in the software consist of the single variable format type.



Any data that may be changed will be flashing. This flashing indicates user entry mode and is initiated by pressing the ENTER key. The UP arrow key will increase a flashing digit from 0 to 9. The LEFT arrow key moves the flashing digit from right to left. Once the change has been completed, pressing ENTER again stores the variable and stops the flashing. Pressing ESC aborts the change and also exits user entry mode.

The starting (default) screen is always the Measure Menu. The UP arrow key is used to select the desired display. From anywhere in this section the user can press the MENU key to select one of the four Menu Sections.

The UP arrow icon next to all list items on the display is a reminder to scroll through the list using the UP arrow key.

To select a list item for modification, first select the proper menu with the MENU key. Scroll to the list item with the UP arrow key and then press the ENTER key. This tells the system that the user wishes to perform a change on that item. For single item type screens, once the user presses the ENTER key, part or all of the variable will begin to flash, indicating that the user may modify that variable using the arrow keys. However, if the instrument is locked, the transmitter will display the message **Locked!** and will not enter user entry mode. The instrument must be unlocked by entering the proper code value to allow authorized changes to user entered values. Once the variable has been reset, pressing the ENTER key again causes the change to be stored and the flashing to stop. The message **Accepted!** will be displayed if the change is within pre-defined variable limits. If the user decides not to modify the value after it has already been partially changed, pressing the ESC key aborts the modification and returns the entry to its original stored value.

In a menu item which is a multiple variable sequence type, once the ENTER key is pressed there may be several prompts and sequences that are run to complete the modification. The ESC key can always be used to abort the sequence without changing any stored variables.

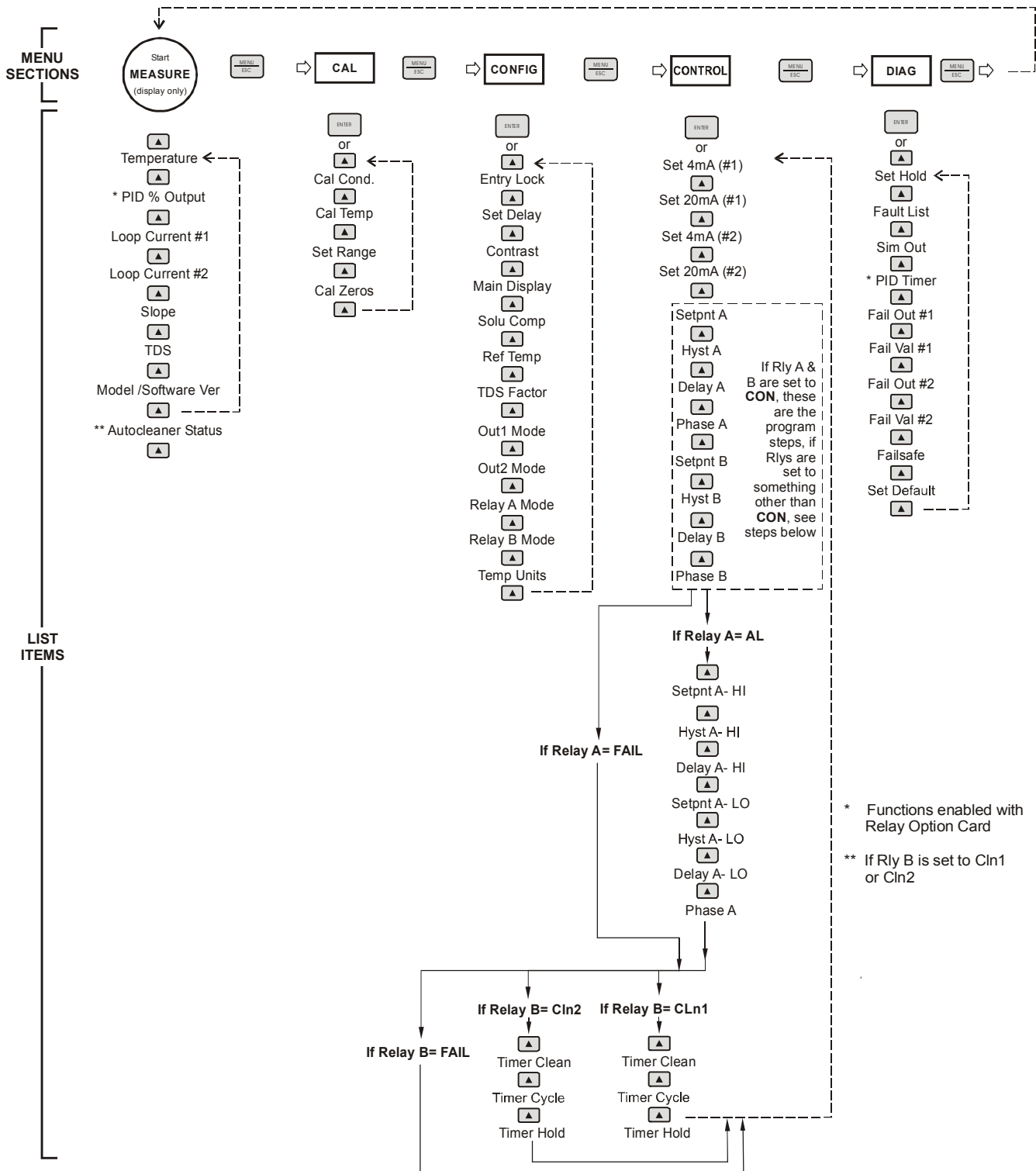


Figure 16 - Software Map



## 5.22 Measure Menu [MEASURE]

The default menu for the system is the display-only menu MEASURE. This menu is a display-only measurement menu, and has no changeable list items. When left alone, the instrument will automatically return to this menu after approximately 30 minutes. While in the default menu, the UP arrow allows the user to scroll through the secondary variables on the lower line of the display. A brief description of the fields in the basic transmitter version is as follows:

### TRANSMITTER MEAS SCREENS:

- 25.7°C** Temperature display. Can be displayed in °C or °F, depending on user selection. A small “m” on the left side of the screen indicates the transmitter has automatically jumped to a manual 25°C setting due to a failure with the temperature signal input.
- 100% 20.00 mA** PID Status screen (if enabled.) Shows the present controller output level on left, and actual transmitter current on the right. The controller can be placed in manual while viewing this screen by pressing and holding the ENTER key for 5 seconds until a small flashing “m” appears on the screen. At that point the controller output can be adjusted up or down using the UP and LEFT arrow keys. To return to automatic operation, press and hold the ENTER key for 5 seconds and the “M” will disappear.
- Loop Current #1** Indicates current output setting on TB1
- Loop Current #2** Indicates current output setting on TB2
- TDS = 200 ppm** Total Dissolved Solids (TDS). Displays TDS of process.
- Q45C2 v4.01** Transmitter software version number.

**Note: A display test (all segments ON) can be actuated by pressing and holding the ENTER key while viewing the model/version number on the lower line of the display.**

For the relay-based analyzer version, or the portable battery powered version of the transmitter, the screens are basically the same, with additions to show two analog outputs instead of one (#1 and #2.)

The MEASURE screens are intended to be used as a very quick means of looking up critical values during operation or troubleshooting.

### 5.23 Calibration Menu [CAL]

The calibration menu contains items for frequent calibration of user parameters. There are four items in this list: Cal Cond, Cell Temp, Set Range, and Cal Zeros.

**Cal Cond** The conductivity calibration function allows the user to adjust the transmitter offset and span reading to match reference buffers, or to adjust the sensor offset to match the sample reading. See Part 6 - Calibration for more details.

**Cal Temp** The temperature calibration function allows the user to adjust the offset of the temperature response by a small factor of  $\pm 5$  °C. The temperature input is factory calibrated to very high accuracy. However, long cable lengths and junction boxes may degrade the accuracy of the temperature measurement in some extreme situations. Therefore, this feature is provided as an adjustment. See Part 6 - Calibration for more details.

**Set Range** This function allows the user to set the display range of the transmitter for a specific application. Once set, all output functions use this display range to establish configuration settings. Press ENTER to initiate user entry mode, and the value will flash. Use the arrow key to modify the range for the desired range and then press ENTER.

**Cal Zeros** This function calibrates all range zero-points to the specific sensor being used. This function is only required to be performed once at initial start-up or when the sensor has been replaced. See Part 6 - Calibration for more details.

## 5.24 Configuration Menu [CONFIG]

The Configuration Menu contains all of the general user settings:

### Entry Lock

This function allows the user to lock out unauthorized tampering with instrument settings. All settings may be viewed while the instrument is locked, but they cannot be modified. The Entry Lock feature is a toggle-type setting; that is, entering the correct code will lock the transmitter and entering the correct code again will unlock it. The code is preset at a fixed value. Press ENTER to initiate user entry mode and the first digit will flash. Use arrow keys to modify value. **See end of manual for the Q45CT lock/unlock code.** Press ENTER to toggle lock setting once code is correct. Incorrect codes do not change state of lock condition.

### Set Delay

The delay function sets the amount of damping on the instrument. This function allows the user to apply a first order time delay function to the conductivity measurements being made. Both the display and the output value are affected by the degree of damping. Functions such as calibration are not affected by this parameter. The calibration routines contain their own filtering and stability monitoring functions to minimize the calibration timing. Press ENTER to initiate user entry mode, and the value will flash. Use the arrow keys to modify value; range is 0.1 to 9.9 minutes. Press ENTER to store the new value.

### Contrast

This function sets the contrast level for the display. The custom display is designed with a wide temperature range, Super-Twist Nematic (STN) fluid.

The STN display provides the highest possible contrast and widest viewing angle under all conditions. Contrast control of this type of display is generally not necessary, so contrast control is provided as a means for possible adjustment due to aging at extreme ranges. In addition, the display has an automatic temperature compensation network. Press ENTER to initiate user entry mode, and the value will flash. Use arrow keys to modify the value; range is 0 to 8 (0 being lightest). Press ENTER to update and store the new value.

**Main Display**

This function allows the user to change the measurement in the primary display area. The user may select between conductivity, sensor temperature, or output current. Using this function, the user may choose to put temperature in the main display area and conductivity on the secondary, lower line of the display. Press ENTER to initiate user entry mode, and the entire value will flash. Use the UP arrow key to modify the desired display value. Press ENTER to store the new value.

**Solu Comp**

This function sets the correction slope value for the linear temperature compensation method and is used when the “Temp Mode” is set to **Lin**. Linear compensation is the method recommended for most aqueous solutions, and the value is typically 2.00 %/°C (25°C reference temperature) for neutral water. This is the factory default and it provides the best compensation for most aqueous solutions. Other typical ranges include:

Acids:	1.0 to 1.6%/°C
Bases:	1.8 to 2.0%/°C
Salts:	2.2 to 3.0%/°C

**NOTE:** If the temperature units are changed between °C and °F (see Temp Units in this Section), the default setting for this output will change between 2.00 %/°C and 1.11%/°F accordingly.

Other compensation slopes for uncommon solutions may be found in chemical handbooks (such as the CRC). Press ENTER to initiate user entry mode, and the entire value will flash. Use the arrow keys to modify the desired value; entry range is 0.000%/°C (no compensation) to 4.000%/°C. Press ENTER to store the new value.

**Ref Temp**

The reference temperature function sets the basis point for the linear temperature compensation methods. In most cases this setting should be left at the default of 25.0 °C.

Press ENTER to initiate user entry mode, and the entire value will flash. Use the arrow keys to modify the desired value; range is 0.0°C to 50.0°C. Press ENTER to update and store the new value. This setting appears in the Software Menu only if “Temp Mode” is set to **Lin**.

- TDS Factor** This function sets the linear relationship of the TDS (total dissolved solids) reading to the conductivity measurement. The actual units for the slope are in mg/L/ $\mu$ S. The default value is 00.49 mg/L/ $\mu$ S.
- Press ENTER to initiate user entry mode, and the entire value will flash. Use the arrow keys to modify the desired value; range is 00.00 mg/L/ $\mu$ S to 99.99 mg/L/ $\mu$ S. Press ENTER to update and store the new value.
- Out 1 Mode** This assigns the 4-20 mA output #1 to either  $\mu$ S (by selecting 1) or for PID output (by selecting 2)
- Out 2 Mode** This assigns the 4-20 mA output # 2 to Temperature (by selecting 1),  $\mu$ S (by selecting 2) or mg/L (by selecting 3)
- Relay A Mode** Relay A can be used in three different ways: as a setpoint control, as a fail alarm, or as a HI-LO alarm band. The three settings for Rly A Mode are **CON**, **FAIL** and **AL**.
- The **CON** setting enables normal control operation for Relay A, with settings for setpoint, hysteresis, delay and phasing appearing in the CONFIG menu automatically. See Figure 17 for further details.
- The **FAIL** setting enables the fail alarm mode for Relay A. Relay A will then trip on any condition that causes the FAIL icon to be displayed on the LCD. Using this mode allows the User to send alarm indications to other remote devices.
- The **AL** setting allows two setpoints to be selected for the same relay, producing a HI-LO alarm band. In this mode, Relay A will trip inside or outside of the band, depending upon the Phase selected. See Figure 18 for further details.
- Relay B Mode** Relay B can be used in a number of ways: as a setpoint control, or as an alarm. The two settings for Relay B Mode are **CON** and **FAIL**.
- The **CON** setting enables normal setpoint operation for Relay B. Relay B then operates identically to Relay A, with settings for setpoint, hysteresis, delay and phasing appearing in the CONFIG menu automatically. See Figure 17 for details.
- The **FAIL** setting enables the fail alarm mode for Relay B. Relay B will then trip on any condition that causes the FAIL



icon to be displayed on the LCD. Using this mode allows the User to send alarm indications to other remote devices. See Figure 18 for details.

### Temp Units

This function sets the display units for temperature measurement. Press ENTER to initiate user entry mode, and the entire value will flash. Use the UP arrow key to modify the desired display value. The choices are °F and °C. Press ENTER to store the new value.

## 5.25 Control Menu [CONTROL]

The Control Menu contains all of the output control user settings:

### Set 4 mA (#1)

### Set 20 mA (#1)

These functions set the main 4 and 20 mA current loop output points for the transmitter. The units displayed depend on the selection made in the CONFIG menu for I out #1 Mode. Also, when the Relay Option Board is installed, the units will also display #1 or #2 – since there are actually two analog outputs present in this version. Typically set 4 & 20 mA are used for conductivity.

The value stored for the 4 mA point may be higher or lower than the value stored for the 20 mA point. The entry values are limited to values within the range specified in “Set Range”, and the 4 mA and the 20 mA point must be separated by at least 1% of this range. Use the LEFT arrow key to select the first digit to be modified. Then use the UP and LEFT arrow keys to select the desired numerical value. Press ENTER to store the new value.

### \*Set 4 mA (#2)

### \*Set 20 mA (#2)

[temp/conductivity]

These functions set the second 4 mA and 20 mA current loop output points for the transmitter. The output may be set to track temperature (default), or conductivity. The values stored for the 4 mA point may be higher or lower than the value stored for the 20 mA point.

The entry value is limited to a value between 0 and 110°C if it is set for temperature, within the range specified in “Set Range” if the output is set to track conductivity. The 4 mA and the 20 mA point must be at least 20 units away from each other. Press ENTER to initiate user entry mode, and

the value will flash. Use arrow keys to modify value. Press ENTER to store the new value.

*NOTE:* If the temperature units are changed between °C and °F (see Temp Units in this section), the default settings for this output will be stored (present data is not converted.)

*NOTE:* If the battery board option is installed, the menu will be shown as **Set 0 V #2** – since the battery board has two 0-2.5 VDC voltage output signals instead of current outputs.

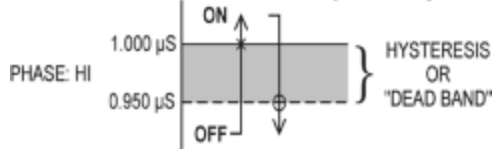
### ALARM CONFIGURATIONS APPLY TO AC POWERED UNITS ONLY

- \*A Setpoint** This function establishes the conductivity trip point for relay A. The entry value is limited to a value within the range specified in “Set Range”. Use the LEFT arrow key to select the first digit to be modified. Then use the UP and LEFT arrow keys to select the desired numerical value. Press ENTER to store the new value.
- \*A Hysteresis** This function establishes the hysteresis, or “deadband”, for Relay A. Hysteresis is most often used to control relay chattering; however, it may also be used in control schemes to separate the ON/OFF trip points of the relay. Press ENTER to initiate user entry mode, and the value will flash. Use the arrow keys to modify value. Press ENTER to store the new value.
- \*A Delay** This function places an additional amount of time delay on the trip point for relay A. This delay is in addition to the main delay setting for the controller. The entry value is limited to a value between 0 and 999 seconds. Press ENTER to initiate user entry mode, and the value will flash. Use arrow keys to modify value; range is 0 to 999 seconds. Press ENTER to store the new value.
- \*A Phasing** This function establishes the direction of the relay trip. When phase is HI, the relay operates in a direct mode. Therefore, the relay energizes and the LCD indicator illuminates when the conductivity value **exceeds** the setpoint. When the phase is LO, the relay energizes and the LCD indicator illuminates when the conductivity level drops **below** the setpoint. The failsafe setting does have an impact on this logic. The description here assumes the failsafe setting is OFF. Press ENTER to initiate user entry mode,

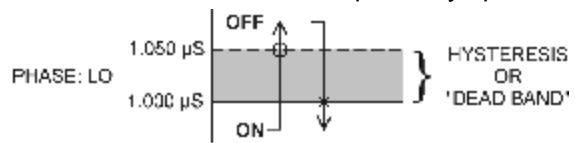
and the entire value will flash. Use the UP arrow key to modify the desired value; selections include **HI** for direct operation or **LO** for reverse operation. Press ENTER to store the new value.

See Figure 17 below for a visual description of a typical control relay application.

When value rises to  $\geq 1.000 \mu\text{S}$ , relay closes.



When value falls to  $\leq 1.000 \mu\text{S}$ , relay opens.



When value rises to  $\geq 1.000 \mu\text{S}$ , relay opens.

When value falls to  $\leq 1.000 \mu\text{S}$ , relay closes.

<b>Settings:</b>	Setpoint:	1.000 $\mu\text{S}$
	Hyst:	0.050
	Delay:	000
	Failsafe:	OFF

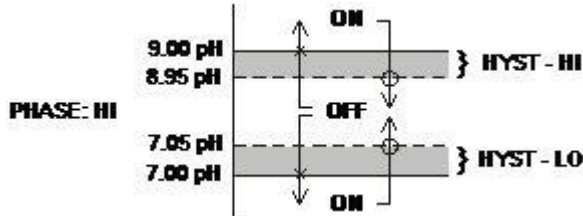
**Figure 17 - Control Relay Example**

- \*Setpnt A-HI
- \*Hyst A-HI
- \*Delay A-HI
- \*Setpnt A-LO
- \*Hyst A-LO
- \*Delay A-LO

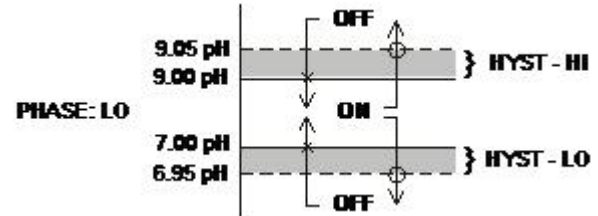
If Relay A Mode is set to Alarm Mode, **AL**, then the following settings will appear in the Config Menu list automatically. In this mode, two setpoints can be selected on the same relay, to create an alarm band. Phase HI selection causes the relay to energize outside of the band, and Phase LO causes the relay to energize inside of the band. This feature enables one relay to be used as a control relay while the other is used as a HI-LO Alarm relay at the same time. Setpoint A-LO must be set lower than Setpoint A-HI. When AL mode is first selected, Setpoint A-LO is defaulted to 0.

Figure 18 is a visual description of a typical alarm relay application.

When value rises to  $\geq 1.000 \mu\text{S}$ , relay closes, until value falls back to  $\leq 0.950 \mu\text{S}$ .



When value falls to  $\leq 0.500 \mu\text{S}$ , relay closes, until value rises back to  $\geq 0.550 \mu\text{S}$ .



When value falls to  $\leq 1.000 \mu\text{S}$ , relay closes, until value rises back to  $\geq 1.050 \mu\text{S}$ .

Setpoint A-HI: 1.000  $\mu\text{S}$   
 Hyst A-HI: 0.050  
 Delay A-HI: 000

When value rises to  $\geq 0.500 \mu\text{S}$ , relay closes, until value falls back to  $\leq 0.450 \mu\text{S}$ .

Setpoint A-LO: 0.500  $\mu\text{S}$   
 Hyst A-LO: 0.05  
 Delay A-LO: 000

Figure 18 - Alarm Relay Example

- \*B Setpoint
- \*B Hysteresis
- \*B Delay
- \*B Phasing

If Relay B Mode is set to **CON** (see **Relay B Mode**), then Relay B will function identically to Relay A. Relay B settings appear in the CONFIG menu list automatically.

### 5.26 Diagnostics Menu [DIAG]

The diagnostics menu contains all of the user settings that are specific to the system diagnostic functions, as well as functions that aid in troubleshooting application problems.

#### Set Hold

The Set Hold function locks the current loop output values on the present process value, and halts operation of the PID controller. This function can be used prior to calibration, or when removing the sensor from the process, to hold the output in a known state. Once HOLD is released, the outputs return to their normal state of following the process input. The transfer out of HOLD is bumpless on the both analog outputs - that is, the transfer occurs in a smooth manner rather than as an abrupt change. An icon on the display indicates the HOLD state, and the HOLD state is retained even if power is cycled. Press ENTER to initiate user entry mode, and entire value will flash. Use the UP

arrow key to modify the desired value, selections are **ON** for engaging the HOLD function, and **OFF** to disengage the function. Press ENTER to store the new value.

**Note:** When the Relay Option Board is installed, the Set Hold function holds BOTH current levels, as well as ALL relay settings.

The Set Hold function can also hold at an output value specified by the user. To customize the hold value, first turn the HOLD function on. Press the ESC key to go to the DIAG Menu and scroll to Sim Output using the UP arrow key. Press ENTER. Follow the instructions under Sim Output (see following page).

**CAUTION:** There is no time-out on the hold feature. Once placed into hold mode, return to normal operation must be done manually.

### Fault List

The Fault List screen is a read-only screen that allows the user to display the cause of the highest priority failure. The screen indicates the number of faults present in the system and a message detailing the highest priority fault present. Note that some faults can result in multiple displayed failures due to the high number of internal tests occurring. As faults are corrected, they are immediately cleared.

Faults are not stored; therefore, they are immediately removed if power is cycled. If the problem causing the faults still exists, however, faults will be displayed again after power is re-applied and a period of time elapses during which the diagnostic system re-detects them. The exception to this rule is the calibration failure. When a calibration fails, no corrupt data is stored. Therefore, the system continues to function normally on the data that was present before the calibration was attempted.

After 30 minutes or if power to the transmitter is cycled, the failure for calibration will be cleared until calibration is attempted again. If the problem still exists, the calibration failure will re-occur. Press ENTER to initiate view of the highest priority failure. The display will automatically return to normal after a few seconds.

### PID Timer

This function sets a timer to monitor the amount of time the PID controller remains at 0% or 100%. This function only

appears if the PID controller is enabled. If the timer is set to 0000, the feature is effectively disabled. If the timer value is set to any number other zero, a FAIL condition will occur if the PID controller remains at 0% or 100% for the timer value. If one of the relays is set to FAIL mode, this failure condition can be signaled by a changing relay contact.

Press ENTER to initiate user entry mode, and the entire value will flash. Use the UP arrow key to modify desired value; range of value is 0-9999 seconds. Press ENTER to store the new value.

### Sim Out

The Sim Out function allows the user to simulate the chlorine level of the instrument in the user selected display range. The user enters a ppm value directly onto the screen, and the output responds as if it were actually receiving the signal from the sensor. This allows the user to check the function of attached monitoring equipment during set-up or troubleshooting. Escaping this screen returns the unit to normal operation. Press ENTER to initiate the user entry mode, and the right-most digit of the value will flash. Use arrow keys to modify desired value.

The starting display value in SIM mode will be the last read value of the input. The output will be under control of the SIM screen until the ESC key is pressed. The instrument will automatically terminate the simulated output after 30 minutes and return to normal operation unless the "HOLD" function is engaged.

*Note:* If the HOLD function is engaged before the Sim Output function is engaged, the simulated output will remain the same even when the ESC key is pressed. Disengage the HOLD function to return to normal output.

### Fail Out

This function enables the user to define a specified value that the main current output will go to under fault conditions. When the Relay Option Board is installed, the display will read **Fail Out #1**. When enabled to **ON**, the output may be forced to the current value set in **Fail Val** (next item.) With the Fail Out setting of ON, and a Fail Val setting of 6.5 mA, any alarm condition will cause the current loop output to drop outside the normal operating range to exactly 6.5 mA, indicating a system failure that requires attention.

Press ENTER to initiate user entry mode, and the entire value will flash. Use the UP arrow key to modify desired value; selections are **ON**, **OFF**. Press ENTER to store the new value.

**Fail Val**

Sets the output failure value for lout#1. When **Fail Out** above is set to **ON**, this function sets value of the current loop under a FAIL condition. When the Relay Option Board is installed, the display will read **Fail Out #1**. The output may be forced to any current value between 4-20 mA.

Press ENTER to initiate user entry mode, and the entire value will flash. Use the UP arrow key to modify desired value; selections are between **4mA**, and **20mA**. Press ENTER to store the new value.

**AC POWERED UNITS ONLY****Fail Out #2**

This function sets the fail-mode of current loop output #2 under a FAIL condition. The settings and operation are identical to Fail Out for output #1.

**Fail Val #2**

This function sets the value of current loop output #2 under a FAIL condition. The settings and operation are identical to Fail Out for output #1.

**AC POWERED UNITS ONLY****\*Failsafe**

This function allows the user to set the optional system relays to a failsafe condition. In a failsafe condition, the relay logic is reversed so that the relay is electrically energized in a normal operating state. By doing this, the relay will not only change state when, for example, a chlorine limit is exceeded, but also when power is lost to the controller.

When failsafe is selected to be ON, the normally-open contacts of the relay will be closed during normal operation. In an attempt to make this configuration less confusing, the LCD icon logic is reversed with this setting, and the icon is OFF under this normal condition. Therefore, when the trip condition occurs, the closed N.O. contacts will be opened (relay de-energized), and the LCD icon will illuminate. In addition, a power fail would also cause the same contacts to open.

**Set Default**

The Set Default function allows the user to return the instrument back to factory default data for all user settings or for just the calibration default. It is intended to be used as a last resort troubleshooting procedure. All user settings or the calibration settings are returned to the original factory values. Hidden factory calibration data remains unchanged. Press ENTER to initiate user entry mode and select either All or CAL with the UP arrow key.



# Part 6 – Calibration

---

## 6.1 Overview and Methods

Calibration of the Q45CT is required to accurately match the sensor characteristics to the monitor/analyzer. Since the output of the conductivity sensor does not degrade over time, it is typically only required that the sensor be calibrated at initial installation and then cleaned periodically to maintain proper system accuracy.

It is important for the user to establish a periodic cleaning and calibration-check schedule for sensor maintenance to maintain high system accuracy. Since the conductivity of a solution is greatly affected by temperature, proper settings for thermal compensation are critical for accurate operation. Before calibrating the instrument for the very first time, it is important to select the proper operating parameters in the configuration menus for temperature compensation methods. Also at initial installation, a temperature calibration must be performed before conductivity can be calibrated.

When using conductivity calibration standards for a wet calibration, take care not to inadvertently contaminate the reference solution; always thoroughly clean the sensor, rinsing off in tap water, and then finish rinsing in pure or de-ionized water. In addition, note that calibration solutions less than 200  $\mu\text{S}$  or greater than 100 mS can be very unstable. Moving the sensor back and forth between different value conductivity reference solutions can quickly contaminate the solutions and render them inaccurate.

### 6.11 1-Point Calibration Explained

The 1-point calibration method is generally known as the "grab sample" calibration method. In the 1-point calibration method, the sensor may be removed from the application and placed into a reference solution. It may also be left in the measurement process and calibrated by reference. The 1-point calibration adjusts the sensor slope to match the exact calibration point. Readings beyond that point are then extrapolated from the determined slope of the calibration line. Since the sensor slope does not degrade over time, frequent re-calibration is unnecessary. Calibration accuracy can be optimized by calibrating with a reference solution which is close to the values typically measured.

### 6.12 Zero Cal Calibration Explained

The sensor offset must be set for the system only on initial sensor installation, or when the cable length has been altered. The Zero Cal method establishes all of the sensor offset points for the instrument's 6 ranges of operation.

## 6.2 Performing a Sensor Zero Calibration

The sensor offset **MUST** be set for the system on initial sensor installation, or when the cable length has been altered. However, it can easily be adjusted at any time by re-calibrating the sensor in air. The sensor zero-calibration generally has little effect in measurements above about 50 mS, but it can have a significant effect in measurements below about 1 mS. If the sensor zero cal is to be performed, it must be done **BEFORE** the 1-point reference calibration.

To begin the sensor zero cal, verify that the sensor is connected and clean and dry. It should be placed in the air with the electrodes at least 1 foot away from any nearby objects. Holding it is not recommended – place on table or just hang.

### Procedure

1. Remove sensor from process and clean thoroughly. Dry sensor and position on table or hang in air (in air is best.) If on table, let end of sensor hang over edge of table.
2. Scroll to the CAL menu section using the MENU key and press ENTER or the UP arrow key. Scroll to the menu **Zero Cal**.
3. Press the ENTER key. The screen will prompt the user to position the sensor in air.
4. Press the ENTER key. The screen will automatically scroll through all ranges and establish and store the proper zero points.

## 6.3 Performing a 1-Point Calibration

This calibration method is intended to be used as an on-line calibration method or a wet-cal with reference solutions. During calibration, the system will display the current conductivity reading, and the user can manually enter a reference value from a reference solution bottle or a comparative reference instrument.

For wet calibrations, the user may use pre-made calibration references (also available from ATI) or a NaCl solution may be made using pure, dried NaCl crystals and one liter of high purity, de-ionized, CO<sub>2</sub>-free water as mixed in the table shown in Figure 19. All table data is at 25°C - therefore, the sensor must be at this temperature to calibrate properly using the table data. If another reference calibration solution is being used, be sure to note temperature of reference solution before calibration. Since the sensor must ideally be at the specified temperature, wet calibrations can be difficult to perform accurately.

NaCl Reference Solution for Calibration (25°C)	
µS/cm	NaCl (gm)
100	0.05
200	0.10
500	0.25
1000	0.50
2000	1.01
3000	1.53
4000	2.06
5000	2.61
8000	4.34
10000	5.56
20000	11.59

**Figure 19 - NaCl Reference Solution for Calibration**

During the 1-point calibration, the system will automatically pick the correct range for the calibration reference if the Q45CT is in the **AUTO** range (see Section 6.11). If the Q45CT is in a normal display mode, the user must be careful to calibrate with a solution that falls into the manual range selected. If the calibration solution is outside the manual range, an error will result.

### Procedure

1. If a zero calibration on the sensor is also to be performed, that must be done **FIRST**. The zero calibration process can have an impact on the result of the 1-point calibration. So if a zero cal is required, do that procedure and return here.
2. Determine whether the calibration will be done on-line or with the sensor removed and placed into a reference solution. If the sensor is removed from the application, rinse and clean. When calibrating a toroid sensor in a beaker of reference solution, there must be plenty of clearance between the sensor and any nearby objects – at least 2 inches. Also, gently stir sensor back and forth to remove any bubbles that may be present in the inner bore.
3. If the sensor has been removed and placed into a solution, allow the sensor to temperature equilibrate with the solution as much as possible. With the sensor coming from an application that differs greatly in temperature, the user may have to wait as much as 20 minutes. If the sensor is on-line, the user may want to set the output HOLD feature prior to calibration to lock out any output fluctuations.

4. Scroll to the CAL menu section using the MENU key and press ENTER or the UP arrow key. Scroll until **Cal Cond** is displayed. Press ENTER.
5. The screen will prompt the user to place the sensor into the reference solution (ideally this has already been done to achieve temperature equilibrium.) Once sensor is ready, press ENTER.
6. The system now begins acquiring data for the calibration value. As data is gathered, the units for conductivity and temperature may flash. Flashing units indicate that this parameter is unstable. The calibration data point acquisition will stop only when the data remains stable for a pre-determined amount of time. This can be overridden by pressing ENTER. If the data remains unstable for 10 minutes, the calibration will fail and the message **Cal Unstable** will be displayed.
7. The screen will display the last measured conductivity value and a message will be displayed prompting the user for the reference value. The user must then modify the screen value with the arrow keys and press ENTER. The system then performs the proper checks.
8. If accepted, the screen will display the message **PASS** with the slope value, then it will return to the main measurement display. If the calibration fails, a message indicating the cause of the failure will be displayed and the FAIL icon will be turned on.

#### 6.4 Temperature Calibration

The temperature input is factory calibrated for the highest accuracy. Temperature calibration is not recommended; however, it is provided for applications in which very long cable lengths are needed. For example, at 50 feet, readings may be off  $\pm 0.2$  °C.

The temperature calibration sequence is essentially a 1-point offset calibration that allows adjustments of approximately  $\pm 5$  °C.

The sensor temperature may be calibrated on line, or the sensor can be removed from the process and placed into a known solution temperature reference. In any case, it is critical that the sensor be allowed to reach temperature equilibrium with the solution in order to provide the highest accuracy.

When moving the sensor between widely different temperature conditions, it may be necessary to allow the sensor to stabilize as much as one hour before the calibration sequence is initiated. If the sensor is on-line, the user may want to set the output HOLD (see Section 5.12) feature prior to calibration to lock out any output fluctuations.

## Procedure

1. Scroll to the CAL menu section using the MENU key and press ENTER or the UP arrow key.
2. Press the UP arrow key until **Cal Temp** is displayed.
3. Press the ENTER key. The message **Place sensor in solution then press ENTER** will be displayed. Move the sensor into the calibration reference (if it hasn't been moved already) and wait for temperature equilibrium to be achieved. Press ENTER to begin the calibration sequence.
4. The calibration data gathering process will begin. The message **Wait** will flash as data is accumulated and analyzed. The °C or °F symbol may flash periodically if the reading is too unstable.
5. The message **Adjust temp value then press ENTER** will be displayed, and the right-most digit will begin to flash, indicating that the value can be modified. Using the UP and LEFT arrow keys, modify the value to the known ref solution temperature. Adjustments up to  $\pm 5$  °C from the factory calibrated temperature are allowed. Press ENTER.
6. Once completed, the display will indicate **PASS** or **FAIL**. If the unit fails, the temperature adjustment may be out of range, the sensor may not have achieved complete temperature equilibrium, or there may be a problem with the temperature element. In the event of calibration failure, it is recommended to attempt the calibration again immediately.

## Part 7 – PID Controller Details

---

### 7.1 PID Description

PID control, like many other control schemes, are used in chemical control to improve the efficiency of chemical addition or control. By properly tuning the control loop that controls chemical addition, only the amount of chemical that is truly required is added to the system, saving money. The savings can be substantial when compared to a system which may be simply adding chemical at a constant rate to maintain some minimal addition under even the worst case conditions. The PID output controller is highly advantageous over simple control schemes that just utilize direct (proportional only) 4-20 mA output connections for control, since the PID controller can automatically adjust the “rate” of recovery based on the error between the setpoint and the measured value – which can be a substantial efficiency improvement..

The PID controller is basically designed to provide a “servo” action on the 4-20 mA output to control a process. If the user requires that a measured process stay as close as possible to a specific setpoint value, the controller output will change from 0% to 100% in an effort to keep the process at the setpoint. To affect this control, the controller must be used with properly selected control elements (valves, proper chemicals, etc.) that enable the controller to add or subtract chemical rapidly enough. This is not only specific to pumps and valves, but also to line sizes, delays in the system, etc.

This section is included to give a brief description of tuning details for the PID controller, and is not intended to be an exhaustive analysis of the complexities of PID loop tuning. Numerous sources are available for specialized methods of tuning that are appropriate for a specific application.

### 7.2 PID Algorithm

As most users of PID controllers realize, the terminology for the actual algorithm terms and even the algorithms themselves can vary between different manufacturers. This is important to recognize as early as possible, since just plugging in similar values from one controller into another can result in dramatically different results. There are various basic forms of PID algorithms that are commonly seen, and the implementation here is the most common version; The ISA algorithm (commonly referred to as the “ideal” algorithm.)

$$\text{output} = P \left[ e(t) + \frac{1}{I} \int e(t) dt + D \frac{de(t)}{dt} \right]$$

Where:

output =	controller output
P =	proportional gain
I =	integral gain
D =	derivative gain
t =	time
e(t) =	controller error (e=measured variable – setpoint)

### Figure 20 - Q45CT (Ideal) PID Equation

The most notable feature of the algorithm is the fact the proportional gain term affects all components directly (unlike some other algorithms - like the “series” form.) If a pre-existing controller utilizes the same form of the algorithm shown above, it is likely similar settings can for made if the units on the settings are exactly the same. Be careful of this, as many times the units are the reciprocals of each other (i.e. reps-per-min, sec-per-rep.)

PID stands for “proportional, integral, derivative.” These terms describe the three elements of the complete controller action, and each contributes a specific reaction in the control process. The PID controller is designed to be primarily used in a “closed-loop” control scheme, where the output of the controller directly affects the input through some control device, such as a pump, valve, etc.

Although the three components of the PID are described in the setting area (section 5.26), here are more general descriptions of what each of the PID elements contribute to the overall action of the controller.

- P Proportional gain. With no “I” or “D” contribution, the controller output is simply a factor of the proportional gain multiplied by the input error (difference between the measured input and the controller setpoint.) Because a typical chemical control loop cannot react instantaneously to a correction signal, proportional gain is typically not efficient by itself – it must be combined with some integral action to be useful. Set the P term to a number between 2-4 to start. Higher numbers will cause the controller action to be quicker.
  
- I Integral gain. Integral gain is what allows the controller to eventually drive the input error to zero – providing accuracy to the control loop. It must be used to affect the accuracy in the servo action of the controller. Like proportional gain, increasing integral gain results in the control action happening quicker. Set the I term to a number between 3-5 to start (1-2 more than P). Like proportional gain, increasing the integral term will cause the controller action to be quicker.

- D Derivative gain. The addition of derivative control can be problematic in many applications, because it greatly contributes to oscillatory behavior. In inherently slow chemical control process', differential control is generally added in very small amounts to suppress erratic actions in the process that are non-continuous, such as pumps and valves clicking on and off. However, as a starting point for chemical process control, its best to leave the "D" term set to 0.

Based on these descriptions, the focus on tuning for chemical applications really only involves adjustment of "P" and "I" in most cases. However, increasing both increases the response of the controller. The difference is in the time of recovery. Although combinations of high "P's" and low "I" will appear to operate the same as combinations of low "P's" and high "I's", there will be a difference in rate of recovery and stability. Because of the way the algorithm is structured, large "P's" can have a larger impact to instability, because the proportional gain term impacts all the other terms directly. Therefore, keep proportional gain lower to start and increase integral gain to achieve the effect required.

Many of the classical tuning techniques have the user start with all values at 0, and then increase the P term until oscillations occur. The P value is then reduced to ½ of the oscillatory value, and the I term is increased to give the desired response. This can be done with the Q45H controller, with the exception that the I term should start no lower than 1.0.

If it appears that even large amounts of integral gain (>20) don't appreciably increase the desired response, drop I back to about 1.0, and increase P by 1.00, and start increasing I again. In most chemical control schemes, I will be approximately 3 times the value of P.

### 7.3 Classical PID Tuning

Unlike many high speed position applications where PID loops are commonly used, the chemical feed application employed by this instrument does not require intense mathematical exercise to determine tuning parameters for the PID. In fact, the risk of instability is far greater with overly tuned PID control schemes. In addition, many of the classical mathematical exercises can be damaging or wasteful in the use of chemicals when the process is bumped with large amounts of input error to seek a response curve. Because of this, the general adjustment guidelines described in section 7.2 are sufficient for almost all application tuning for this instrument. Beyond this, many sources are available for classical tuning methods.



## 7.4 Manual PID Override Control

The Q45 PID output function allows the user to take manual control of the PID control signal. This is often useful when starting up a control loop, or in the event that you wish to bump the system manually to measure system response time.

To access the manual PID control, you must be in the MEASURE mode of operation and you must have the PID output displayed on the lower line. This line will indicate “XX.X% XX.X mA” with the X values simply indicating the current values. With this display on the screen, press and hold the ENTER key for about 5 seconds. You will see a small “m” show up between the % value and the mA value. This indicates you are now in manual mode.

Once in manual, you may increase the PID output by pressing the UP arrow or you may decrease the output by pressing the LEFT arrow. This will allow you to drive the PID output to any desired setting.

To revert to normal PID control, press and hold the ENTER key again until the “m” indicator disappears.

## 7.5 Common PID Pitfalls

The most common problem occurring in PID control applications involves the false belief that proper settings on only the PID controller can balance any process to an efficient level.

Close-loop control can only be effective if all elements in the loop are properly selected for the application, and the process behavior is properly understood. Luckily, the nature of simple chemical control process' are generally slow in nature. Therefore, even a de-tuned controller (one that responds somewhat slowly) can still provide substantial improvements to setpoint control. In fact, damaging oscillatory behavior is far more likely in tightly tuned controllers where the user attempted to increase response too much.

When deciding on a PID control scheme, it is important to initially review all elements of the process. Sticking valves, undersized pumps, or delays in reaction times associated with chemical addition can have a dramatic effect on the stability of the control loop. When controlling a chemical mix or reaction, the sensor should be placed in a location that ensures proper mixing or reaction time has occurred.

The easiest processes to control with closed-loop schemes are generally linear, and symmetrical, in nature. For example, controlling level in tank where the opening of valve for a fixed period of time corresponds linearly to the amount that flows into a tank. Chemical control process' can be more problematic when the nature of the setpoint value is non-linear relative to the input of chemical added.

For example, pH control of a process may appear linear only in a certain range of operation, and become highly exponential at the extreme ranges of the measuring scale. In addition, if a chemical process is not symmetrical, that means it responds differentially to the addition and subtraction of chemical. It is important in these applications to study steady-state impact as well as step-change impact to process changes. In other words, once the process has apparently been tuned under normal operating conditions, the user should attempt to force a dramatic change to the input to study how the output reacts. If this is difficult to do with the actual process input (the recommended method), the user can place the control in manual at an extreme control point such as 5% or 95%, and release it in manual. The recovery should not be overly oscillatory. If so, the loop needs to be de-tuned to deal with that condition (reduce P and/or I.)

# Part 8 – System Maintenance

---

## 8.1 System Checks

1. If the FAIL icon is flashing on the display, check the Fault List to determine the cause of the failure. To access the Fault List, press the MENU/ESC key until the DIAG menu appears. Then press the UP arrow key until the Fault List appears. Press the ENTER key to access the Fault List, and the highest priority fault message will be displayed. For a list of all messages and possible causes/solutions, refer to Section 8.4.
2. In **ALL** environments, connect an earth ground jumper to earth terminal connection on transmitter.
3. Perform a sensor zero calibration and a one-point calibration prior to sensor installation.
4. Check sensor cable color to terminal strip markings.
5. For highly unstable behavior, remove sensor from the process and measure the process solution in a plastic beaker. If the reading now stabilizes, check process mount for possible entrapped air. If sensor was mounted in-line in plastic tee, measuring lower conductivity water, ensure no high voltage sources (pumps, AFDs, motor starters, etc) are present within about 1 foot of tee.
6. If the instrument 4-20 mA output is connected into other control systems, disconnect output loop from system load and run through a handheld DMM to monitor current. Also disconnect any relay wiring, if present. Finally, connect power on 110/230 V units with separate line cord and connect to a power outlet in an alternate location. Verify that the system operates correctly in this mode first.

## 8.2 Instrument Checks

1. Remove sensor completely and connect 1100 Ohms from the GREEN to BLACK (green bundle) on the analyzer input leads. The temperature reading should display approximately 25 °C and the conductivity reading should display approximately 0.0 uS.
2. Reconnect the sensor and leave dry in air. With a DMM, measure the AC voltage between RED and BLACK sensor leads. The DMM should read between 100 mVrms and 300 mVrms @ about 10 kHz. The display should show some value close to 0 uS if the sensor has been properly zero calibrated.

3. For the line powered version, verify the proper line voltage power. With power disconnected, verify continuity across the line fuse.
4. For the DC transmitter variation, verify that power supply has required voltage based on size of resistance in current loop. Large resistive loads can reduce available power for transmitter.

### 8.3 Sensor Tests

Toroidal sensors can be tested with a digital voltmeter (DVM) to determine if a major sensor problem exists. Follow the steps below to verify sensor integrity:

- A. Disconnect the nine sensor wires from the terminal strip on the transmitter. Check sensor covering for any mechanical damage to plastic covering.
- B. Connect a DVM between the RED and BLACK wires in the red jacket pair. With the DVM set to measure resistance, you should measure between 0.4 and 2.0 Ohms.
- C. Connect a DVM between the WHITE and BLACK wires in the white jacket pair. With the DVM set to measure resistance, you should measure between 0.4 and 2.0 Ohms.
- D. Connect a DVM between the WHITE wire from the white jacket pair, and the RED wire from the red jacket pair. With the DVM set to measure resistance, you should measure an open circuit.
- E. Connect a DVM between the GREEN and BLACK wires in the green jacket pair. You should find a resistance value that depends on the temperature. The table below lists the resistance values.

Temperature °C	Resistance Ω
0	1000
5	1019
10	1039
15	1058
20	1078
25	1097
30	1117
35	1136
40	1155
45	1175
50	1194

**Figure 21 - Pt1000 RTD Table**

### 8.4 Display Messages

The Q45 Series instruments provide a number of diagnostic messages that indicate problems during normal operation and calibration. These messages appear as prompts on the secondary line of the display or as items on the Fault List.

The following messages will appear as prompts:

MESSAGE	DESCRIPTION	POSSIBLE CORRECTION
<b>Cal Unstable</b>	Calibration problem, data too unstable to calibrate.	Clean sensor, get fresh cal solutions, allow temperature and conductivity readings to fully stabilize, do not handle sensor or cable during calibration.
<b>Slope HIGH</b>	Sensor slope from calibration is greater than 400%.	Get fresh cal solutions, allow temperature and conductivity readings to fully stabilize, check for correct buffer values
<b>Slope LOW</b>	Sensor slope from calibration is less than 20%.	Clean sensor, get fresh cal solutions, allow temperature and conductivity readings to fully stabilize, check for correct buffer values.
<b>Offset HIGH</b>	Sensor offset from calibration is too high	Clean sensor, get fresh cal solutions, allow temperature and conductivity readings to fully stabilize, check for correct solution values.
<b>Out of Range</b>	Input value is outside selected range of the specific list item being configured.	Check manual for limits of the function to be configured.
<b>Locked!</b>	Transmitter security setting is locked.	Enter security code to allow modifications to settings.
<b>Unlocked!</b>	Transmitter security has just been unlocked.	Displayed just after security code has been entered.
<b>TC-F25 lock!</b>	The TC won't calibrate because there is something wrong with the connection to the temperature element in the sensor.	Perform Sensor Tests and Instrument Tests to confirm operation of TC in sensor. Check all connections between sensor and instrument.

The following messages will appear as items on the Fault List:

MESSAGE	DESCRIPTION	POSSIBLE CORRECTION
<b>Sensor High</b>	The raw signal from the sensor is too high.	Check wiring connections to sensor.
<b>Sensor Low</b>	The raw signal from the sensor is too low.	Check wiring connections to sensor.
<b>Cond too High</b>	The conductivity reading is > 2000 mS.	The conductivity reading is over operating range limits. Move to a higher range or select "Auto" from Main Display in CONFIG menu.
<b>Temp High</b>	The temperature reading is > 210 °C.	The temperature reading is over operating limits. Check wiring and expected temp level. Perform RTD test as described in sensor manual. Recalibrate sensor temperature element if necessary.
<b>Temp Low</b>	The temperature reading is < -10 °C	The temperature reading is under operating limits. Check wiring and expected temp level. Perform RTD test as described in sensor manual. Recalibrate sensor temperature element if necessary.
<b>TC Error</b>	TC may be open or shorted.	Check sensor wiring and perform RTD test as described in sensor manual.
<b>Cond Cal Fail</b>	Failure of conductivity calibration.	Clean sensor, get fresh cal solutions and redo calibration. Verify conductivity value of application or reference solutions. Perform sensor tests as described in sensor manual. Replace sensor if still failure.
<b>EEprom Fail</b>	Internal nonvolatile memory failure	System failure, consult factory.
<b>Chcksum Fail</b>	Internal software storage error.	System failure, consult factory.
<b>Display Fail</b>	Internal display driver fail.	System failure, consult factory.
<b>Range Cal Fail</b>	Failure of factory temperature calibration.	Consult factory.

# Spare Parts

---

<b><u>Part No.</u></b>	<b><u>Description</u></b>
07-0041	24 VDC, 2-Wire (Single output only)
07-0042	115 VAC with 2 Relays & 2 Outputs
07-0043	230 VAC with 2 Relays & 2 Outputs
07-0100	Junction box
31-0068	Sensor interconnect cable
63-0099	Toroidal Conductivity Sensor, Noryl
09-0047	Conductivity Standard - 447 microSiemens, 500 mL
09-0048	Conductivity Standard - 1,500 microSiemens, 500 mL
09-0049	Conductivity Standard - 8,974 microSiemens, 500 mL
09-0050	Conductivity Standard - 80,000 microSiemens, 500 mL
23-0018	Fuse, 100mA, 250V, (115VAC units)
23-0019	Fuse, 50mA, 250V, (230VAC units)
03-0313	Q Series Power Supply (rear), 115VAC
03-0314	Q Series Power Supply (rear), 230VAC
03-0336	Q45CT Front Lid Assembly

**Lock/Unlock Code: 1458**