

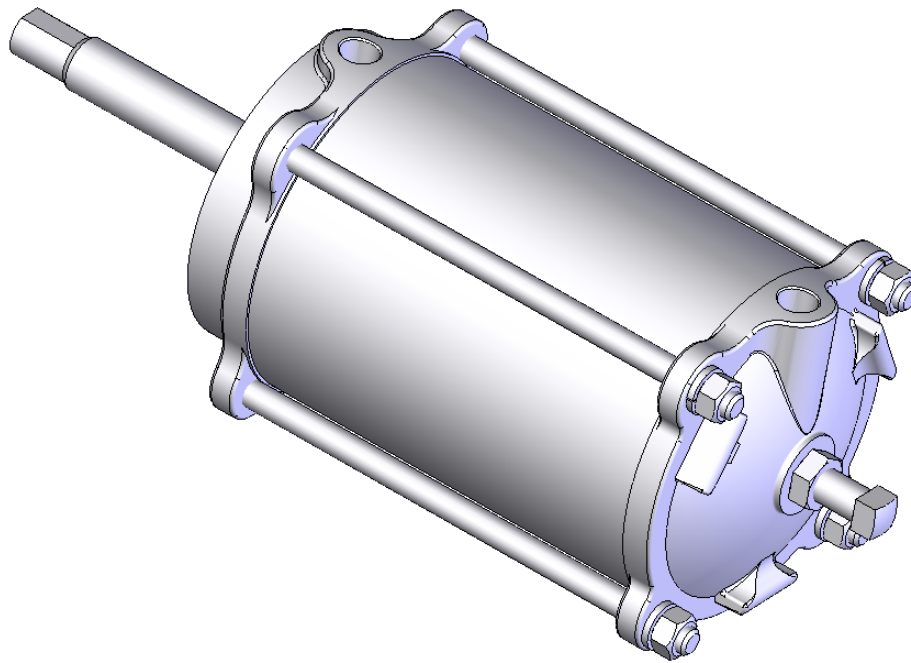

**DeZURIK PNEUMATIC  
CYLINDER OPERATOR  
FOR G-SERIES ACTUATORS**



Instruction D10047  
March 2017

### Instructions

These instructions provide information about pneumatic cylinder operators. They are for use by personnel who are responsible for installation, operation and maintenance of pneumatic cylinder operators.

### Safety Messages

All safety messages in the instructions are flagged with an exclamation symbol and the word Caution, Warning or Danger. These messages indicate procedures that must be followed exactly to avoid equipment damage, personal injury or death. Safety label(s) on the product indicate hazards that can cause equipment damage, personal injury or death. If a safety label becomes difficult to see or read, or if a label has been removed, please contact DeZURIK for replacement label(s).



#### **WARNING!**

**Personnel involved in the installation or maintenance of valves should be constantly alert to potential emission of pipeline material and take appropriate safety precautions. Always wear suitable protection when dealing with hazardous pipeline materials. Handle valves, which have been removed from service with the assumption of pipeline material within the valve.**

---

### Inspection

Your pneumatic cylinder operator has been packaged to provide protection during shipment; however, it can be damaged in transport. Carefully inspect the unit for damage upon arrival and file a claim with the carrier if damage is apparent.

### Parts

Recommended spare parts are listed on the assembly drawing. These parts should be stocked to minimize downtime.

Order parts from your local DeZURIK sales representative, or directly from DeZURIK. When ordering parts, please include the 7-digit part number and 4-digit revision number (example: **9999999R000**) located on the data plate attached to the valve assembly. Also include the part name, the assembly drawing number, the balloon number and the quantity stated on the assembly drawing.

### DeZURIK Service

DeZURIK service personnel are available to install, maintain and repair all DeZURIK products. DeZURIK also offers customized training programs and consultation services.

For more information, contact your local DeZURIK sales representative or visit our website at [www.dezurik.com](http://www.dezurik.com).

## Table of Contents

Description - - - - -	4
Air Supply - - - - -	4
Lubrication - - - - -	4
Adjustment - - - - -	4
Disassembly - - - - -	4
Reassembly - - - - -	5

### Description

This is a Double Acting Cylinder intended for pneumatic service.



#### **WARNING!**

**This is a PRESSURE CONTAINING VESSEL. Release the pressure from both ends of the cylinder before attempting any disassembly or repair.**

---

### Air Supply

Maximum cylinder supply pressure is 100 psi (689 kPa). For maximum cylinder life, the air should be filtered and dry.

### Lubrication

If the cylinder is disassembled, lubricate the cylinder wall, piston seal, O-ring and O-ring groove using one of these lubricants.

- Dow Corning Molykote No. 44 (**recommended**)
- Shell Retinax AM (alternate)
- Shell Lithall MDS (alternate)

### Adjustment

The set screw in the end of the cylinder is used to limit the stroke of the cylinder. Adjust the set screw so the piston rod contacts it when the valve is in the closed position. Lock the set screw in place with the nut. Be sure the thread seal is positioned properly.

### Disassembly

---



#### **WARNING!**

- **Servicing the actuator while the pipeline is under pressure can cause personal injury or equipment damage. Relieve pipeline pressure before servicing the actuator.**
  - **Accidental operation of power actuator can cause personal injury or equipment damage. Disconnect and lock out power to actuator before servicing.**
- 

1. Relieve the pressure in the pipeline and close the valve.
2. Shut off the air supply to the cylinder.
3. Relieve the pressure in the cylinder.
4. Disconnect the cylinder tubing.
5. Remove the nuts and washers from the tie rods and remove the cylinder cap.
6. Remove the O-ring from the cylinder cap.
7. Remove the cylinder tube, rotating it while pulling it off the piston.
8. Remove the nut on the piston rod and remove the piston.
9. Remove the piston seal and its O-ring. Clean the O-ring, seal and groove.
10. Remove the extension cap from the other end of the housing.

## Pneumatic Cylinder Operator for G-Series Actuators

### Disassembly *(continued)*

11. **Eccentric Valves:** Remove the nuts and spring washers from the rack rod.  
**All other valves:** Remove the jam nuts from the rack rod.
12. Pull the piston rod (complete with rack rod) from the cylinder head.
13. Take out the four screws and separate the cylinder head from the actuator housing.
14. Remove the rod seal and O-ring from the cylinder head.

### Reassembly

**NOTE:** It is recommended to use new seals and o-rings when reassembling the cylinder.

1. Lubricate the rod seal, then push it into place in the cylinder head as shown in Figure 1. The back-up rings are cut with a bevel; be sure the ends match up and do not overlap.

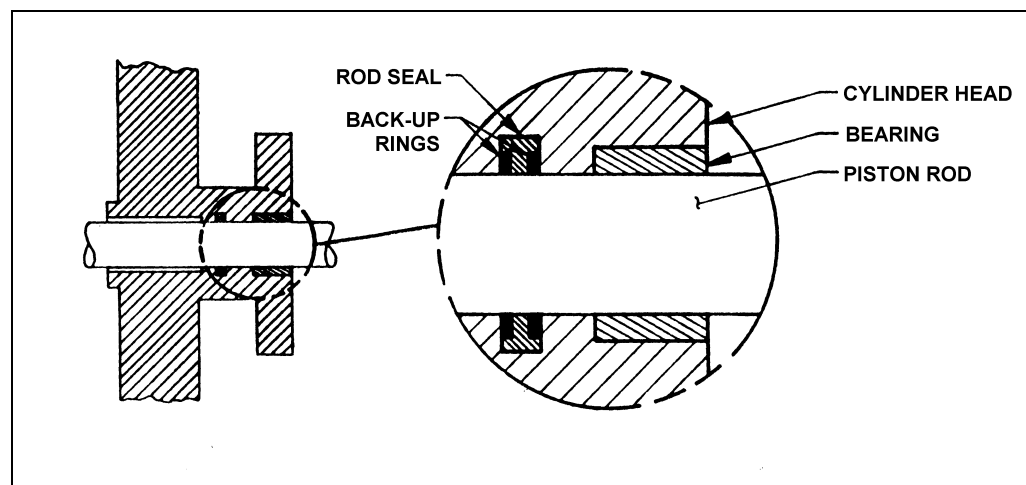

**Figure 1 – Cylinder Component Identification**

2. Mount the cylinder head on the actuator. Fasten the cylinder head to the housing with the four screws removed earlier.
3. Carefully install the rack rod and piston rod.
4. **Eccentric Valves:** Install the spacer, spring washers and nuts on the rack rod. See *Actuator Instructions* for spring washer arrangement.

**All other valves:** Install the jam nuts on the rack rod.

5. **Eccentric Valves:** Tighten the nut until the spring washers are completely compressed and then back off until they return to their normal unstressed shape.

**All other valves:** Tighten the first nut.

6. Tighten the second nut.
7. Install the extension cap.
8. Put the piston on the piston rod and install the nut.
9. Thoroughly lubricate the piston groove, new O-ring, new piston seal and inside of cylinder tube.
10. Slide the small size lubricated O-ring into the counterbore in the piston.
11. Slide the piston onto the piston rod so the O-ring in the piston faces the cylinder head.

**Reassembly** *(Continued)*

12. Install the nut to hold the piston in place and tighten nut to 45 ft. lbs.
13. Slide the medium size lubricated O-ring over the piston until it fits in the groove. See Figure 2.
14. Slide the lubricated piston seal over the piston without stretching it any more than necessary. The seal should fit into the groove over the O-ring. See Figure 2.

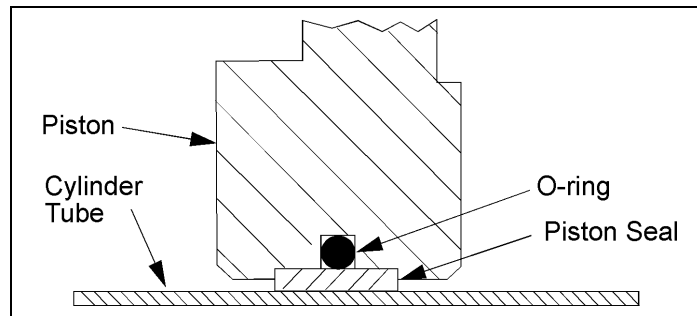
**Figure 2 – Piston Seal Installation**

15. Carefully slide the lubricated cylinder tube over the piston seal. Start with the tube at a 45° angle to the piston, and rotate the tube onto the piston.

**Note:** On 6 inch and larger cylinders, remove tie rods as needed to allow positioning the cylinder tube at a 45° angle. See Figure 3. Replace tie rods after installing the cylinder tube.

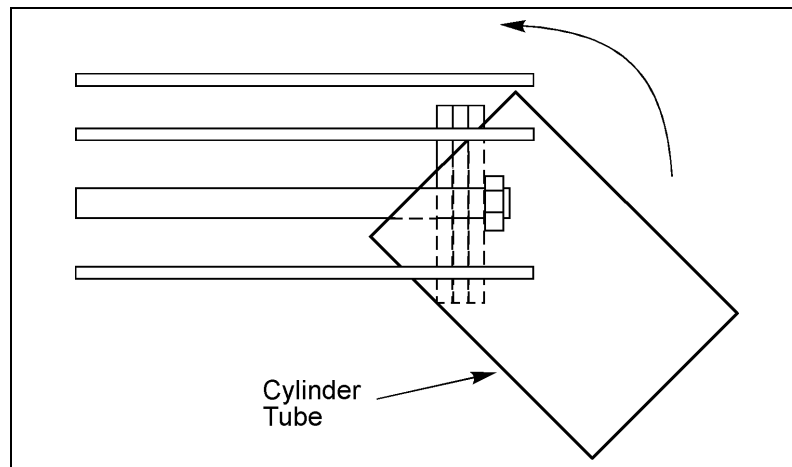
**Figure 3 – Installing Cylinder Tube**

16. Clean the O-ring groove in the cylinder cap.
17. Lubricate and install the O-ring in the cylinder cap.
18. Slide the cylinder cap over the tie rods and push it in until the O-ring slides into the cylinder tube.

## Pneumatic Cylinder Operator for G-Series Actuators

---

### Reassembly *(Continued)*

19. Install the lock washers and nuts on the tie rods. Tighten the nuts to the torque specified in Table A.

**Table A: Tie Rod Nut Torques**

Cylinder Size	Torque		
	(ft lbs)	(cm/kg)	(Nm)
4"	12	175	16
6" & 8"	16	225	22
10" & 12"	20	275	27

20. Reconnect the cylinder tubing.

**Note:** When using flexible tubing, install only one swivel connector per piece of tubing. If the actuator has an accessory piped to the cylinder, place the swivel connector on the accessory port end of the tubing. Otherwise, place the swivel connector on the cylinder port end of the tubing.

21. Reconnect the air supply to the actuator.
22. Check the open and closed position stops and readjust if necessary. See the *Adjustment* section of these Instructions and the *Open Position Adjustment* section of the *Actuator Instructions* for the correct stop adjustment procedures.