

Model B20/62

Free Chlorine Recorder

Home Office

Analytical Technology, Inc.
6 Iron Bridge Drive
Collegeville, PA 19426

Ph: 800-959-0299
610-917-0991

Fax: 610-917-0992

Email: sales@analyticaltechnology.com

European Office

ATI (UK) Limited
Unit 1 & 2 Gatehead Business Park
Delph New Road, Delph
Saddleworth OL3 5DE

Ph: +44 (0)1457-873-318

Fax: + 44 (0)1457-874-468

Email: sales@atiuk.com

PRODUCT WARRANTY

Analytical Technology, Inc. (Manufacturer) warrants to the Customer that if any part(s) of the Manufacturer's equipment proves to be defective in materials or workmanship within the earlier of 18 months of the date of shipment or 12 months of the date of start-up, such defective parts will be repaired or replaced free of charge. Inspection and repairs to products thought to be defective within the warranty period will be completed at the Manufacturer's facilities in Collegeville, PA. Products on which warranty repairs are required shall be shipped freight prepaid to the Manufacturer. The product(s) will be returned freight prepaid and allowed if it is determined by the manufacturer that the part(s) failed due to defective materials or workmanship.

This warranty does not cover consumable items, batteries, or wear items subject to periodic replacement including lamps and fuses.

Gas sensors carry a 12 months from date of shipment warranty and are subject to inspection for evidence of misuse, abuse, alteration, improper storage, or extended exposure to excessive gas concentrations. Should inspection indicate that sensors have failed due to any of the above, the warranty shall not apply.

The Manufacturer assumes no liability for consequential damages of any kind, and the buyer by acceptance of this equipment will assume all liability for the consequences of its use or misuse by the Customer, his employees, or others. A defect within the meaning of this warranty is any part of any piece of a Manufacturer's product which shall, when such part is capable of being renewed, repaired, or replaced, operate to condemn such piece of equipment.

This warranty is in lieu of all other warranties (including without limiting the generality of the foregoing warranties of merchantability and fitness for a particular purpose), guarantees, obligations or liabilities expressed or implied by the Manufacturer or its representatives and by statute or rule of law.

This warranty is void if the Manufacturer's product(s) has been subject to misuse or abuse, or has not been operated or stored in accordance with instructions, or if the serial number has been removed.

Analytical Technology, Inc. makes no other warranty expressed or implied except as stated above

TABLE OF CONTENTS

UNPACKING	3
INTRODUCTION	4
<i>Figure 1 - Chlorine Monitoring System with Internal Transmitter (ATI-0131)</i>	5
<i>Figure 2 - Chlorine Monitoring System with External Transmitter (ATI-0132)</i>	5
SPECIFICATIONS	6
RECORDER UNIT	6
SENSOR.....	6
FLOWCELL ASSEMBLY	6
INSTALLATION	7
<i>Figure 3 - Recorder Installation (ATI-0107)</i>	7
<i>Figure 4 - Flowcell Dimensions (ATI-042)</i>	8
<i>Figure 5 - Sensor Pipe Mount Installation (ATI-0155)</i>	9
<i>Figure 6 - Mounting Assembly Detail (ATI-0188)</i>	10
ELECTRICAL CONNECTIONS	11
<i>Figure 7 - Recorder Customer Connections with Internal Transmitter (ATI-0134)</i>	11
<i>Figure 8- Recorder Customer Connections with Remote Transmitter (ATI-0135)</i>	12
<i>Figure 9 - Junction Box Dimensions (ATI-068)</i>	13
<i>Figure 10 - Junction Box Interconnect Wiring (ATI-0137)</i>	14
CHLORINE SENSOR ASSEMBLY	14
<i>Figure 11 - Chlorine Flow Sensor Assembly (ATI-0246)</i>	16
<i>Figure 12 - Chlorine Submersible Sensor Assembly (ATI-0245)</i>	16
RECORDER PROGRAMMING	17
CHART SPEED SELECTION	17
PROGRAMMING DIGITAL DISPLAY RANGE	17
ALARM HYSTERESIS ADJUSTMENT.....	18
ALARM SETPOINT ADJUSTMENT.....	18
CHART SETUP	19
CHART PAPER INSTALLATION.....	19
PEN INSTALLATION.....	19
OPERATION	20
ZEROING THE SYSTEM.....	20
<i>Figure 13 - Transmitter Test Points, Zero, & Span Potentiometers (ATI-085)</i>	21
FLOW SYSTEM STARTUP	21
CALIBRATION	22
MAINTENANCE	23
SENSOR MAINTENANCE	23
FLOWCELL MAINTENANCE	23
SPARE PARTS LIST	24

UNPACKING

When you receive your B20/62 Chlorine Recorder, open the shipping package and inspect the contents to be sure that all items have been received. The following items should be included:

Quantity 1 - Model B20 Recorder

Quantity 1 - Model A10-62 Chlorine Sensor

Quantity 1 - #03-0029 25 ft. sensor interconnect cable

Quantity 1 - #00-0043 Clear Flowcell Assembly

Quantity 1 - #09-0011 4 Oz. Bottle of Free Chlorine Electrolyte

Quantity 1 - #05-0005 Box of 10 Free Chlorine Membranes

Quantity 1 - #05-0004 Spare Parts Kit, containing o-rings and screws

Quantity 1 - AC Power Cord

Quantity 1 - Model B12/62 Chlorine Transmitter (if remote transmitter option selected)

In addition to the standard items listed above, any additional spare parts, junction boxes, cable, or spare sensors that were ordered separately will be included. Compare the contents of the shipping container with the packing list. The items listed above are the standard components that are included with every standard B20/62 free chlorine monitor. Any other items will be listed separately on the packing list. Check the contents of the shipping container carefully to insure that nothing is overlooked. Should you find anything missing from the shipment, immediately contact the ATI sales department by calling either 800-959-0299 or 610-917-0991. If you prefer, you may send a fax describing the error to 610-917-0992.

INTRODUCTION

The Model B20/62 is an on-line monitoring system designed for the continuous recording of free chlorine in solution. The recorder is well suited for potable water treatment plants, cooling water, reverse osmosis membrane protection, or activated carbon filter break-through detection. Units are available with operating ranges of 0-5 PPM or 0-20 PPM. For units with a range of 0-5 PPM, the recorder may be spanned for any operating ranges between 0-1 and 0-5 PPM. Units with an overall range of 0-20 PPM may be spanned for operating ranges between 0-5 and 0-20 PPM. The sensing system will operate on water streams with temperatures from 0 to 50° C.

The basic sensing element used in the free chlorine recorder is a polarographic membraned sensor which measures chlorine directly. Water simply flows past the sensor and directly to drain, with the flowrate and pressure across the sensor controlled by a constant head flow cell assembly. The chlorine measurement does not alter the sample or add any chemicals to the sample stream, so the water flow can return to the system if desired. Water streams with pH values above 8 may require the use of a CO₂ buffer system to reduce and stabilize the pH prior to measurement.

The measured free chlorine concentration is indicated directly on a 10" circular chart, which may be programmed for 24 hour or 7 day rotation. An LED display provides direct indication of chlorine concentration in addition to the recording. A box of 25 charts are supplied with the basic unit, with a 24 hour chart on one side and a 7 day chart on the other side. Charts are graduated with a 0-100 scale, and additional charts in packages of 100 are available from ATI (see parts list). Recorders employ replaceable felt tip pens for recording chlorine data. The recorder is supplied with one red pen as standard. Additional pens in packages of 6 are available from ATI (see parts list).

The standard model B20/62 system includes three main components, a wall or panel mounted recorder unit, a constant head flow cell, and a free chlorine sensor. For connection of the sensor to the electronics, a 25' cable is supplied. The sensor cable may be extended up to 100 feet by use of a junction box (00-0048) and 5 conductor shielded sensor cable (31-0001) available from ATI. Should an application require location of the sensor more than 100 feet from the recorder, the chlorine amplifier may be located remote from the recorder up to 5000 feet and interconnected with 2 conductor shielded cable (31-0008).

ATI Model B20/62 Free Chlorine Recorder

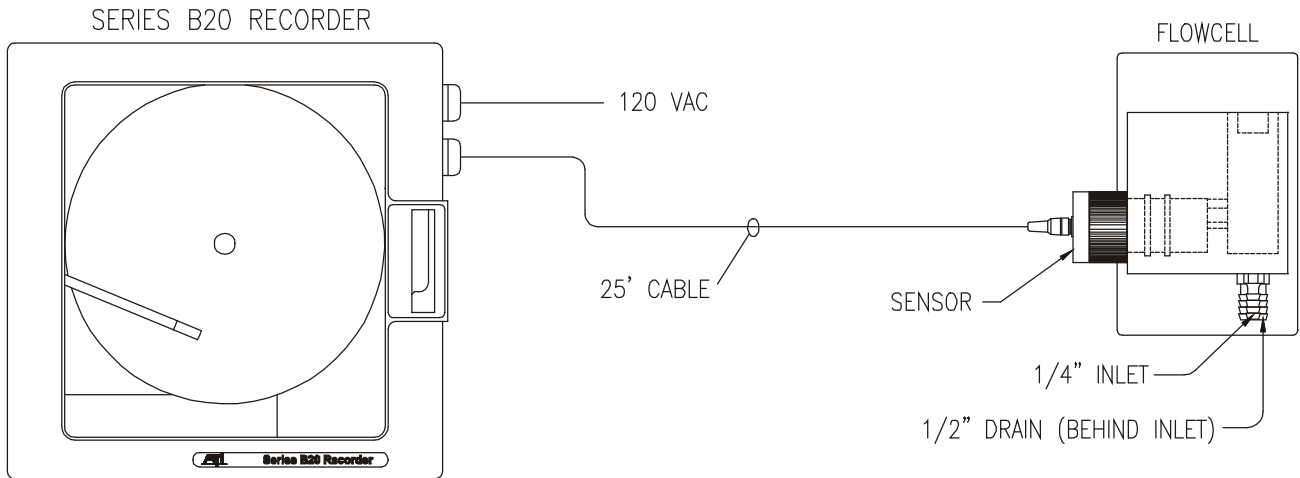

Figure 1 - Chlorine Monitoring System with Internal Transmitter (ATI-0131)

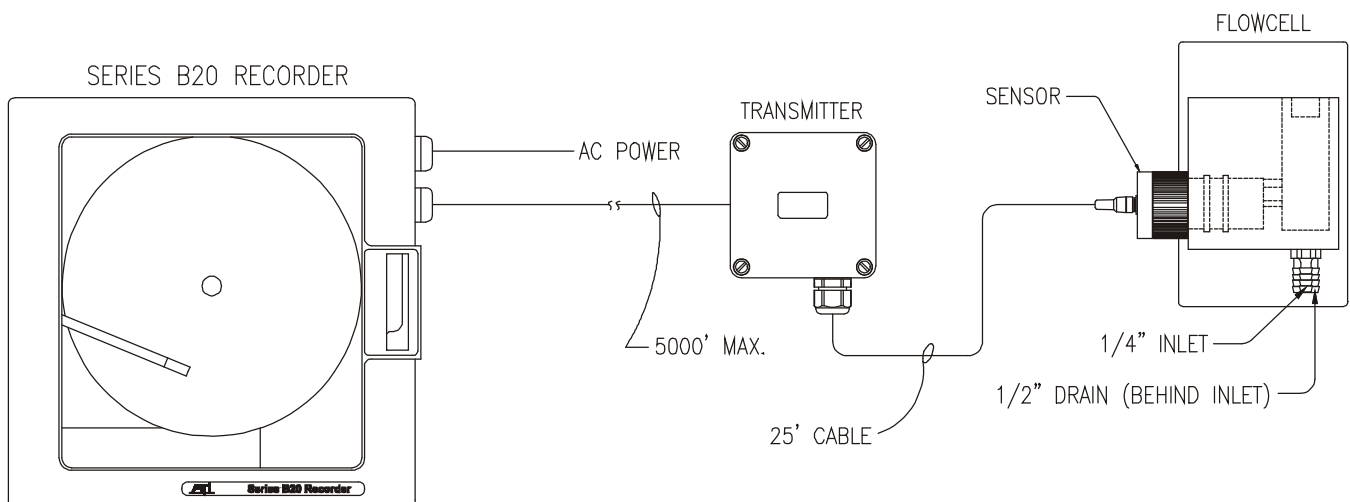

Figure 2 - Chlorine Monitoring System with External Transmitter (ATI-0132)

SPECIFICATIONS

RECORDER UNIT

Range:	0-5 or 0-20 PPM, Selected at ordering time.
Accuracy:	± 0.05 PPM
Repeatability:	± 0.02 PPM
Linearity:	0.5% of F.S.
Display:	4 digit LED
Alarms:	Two programmable setpoints
Alarm Relays:	Two SPDT, 5 A @ 120 VAC resistive
Temperature Compensation:	Automatic from -2° to +52° C.
Recorder Size:	10" Circular Chart
Chart Speed:	Selectable for 24 hour or 7 days per revolution.
Operating Conditions:	0-50° C., 0-95% R.H. non-condensing.
Power:	110/220 VAC ±10%, 50/60 Hz.
Enclosure:	NEMA 3R Noryl, Glass window, wall or panel mount.
Size:	14"W x 14"H x 6"D

SENSOR

Response Time:	90% in 60 seconds.
Temperature Sensor:	100K thermistor
Temperature Limits:	-5° to +55° C.
Connection:	Watertight 6 pin plug
Materials:	Noryl and stainless steel

FLOWCELL ASSEMBLY

Type:	Constant head overflow system
Materials:	Clear Cast Acrylic, stainless steel mounting plate
Inlet Flow:	7-30 GPH, 15 GPH recommended.
Inlet Connection:	1/4" Hose barb
Drain Connection:	1/2" Hose barb
Size:	4.5"W x 7"H x 3.5"D

INSTALLATION

The main installation requirements of ATI's free chlorine recorder are mechanical installation and connection of power to the electronics and water sample to the flowcell.

Figure 3 provides details on the mechanical installation of the recorder unit. Dimensions on the panel cutout are included. Bracket for panel or wall mounting are included with the recorder and are attached as shown in Figure 3.

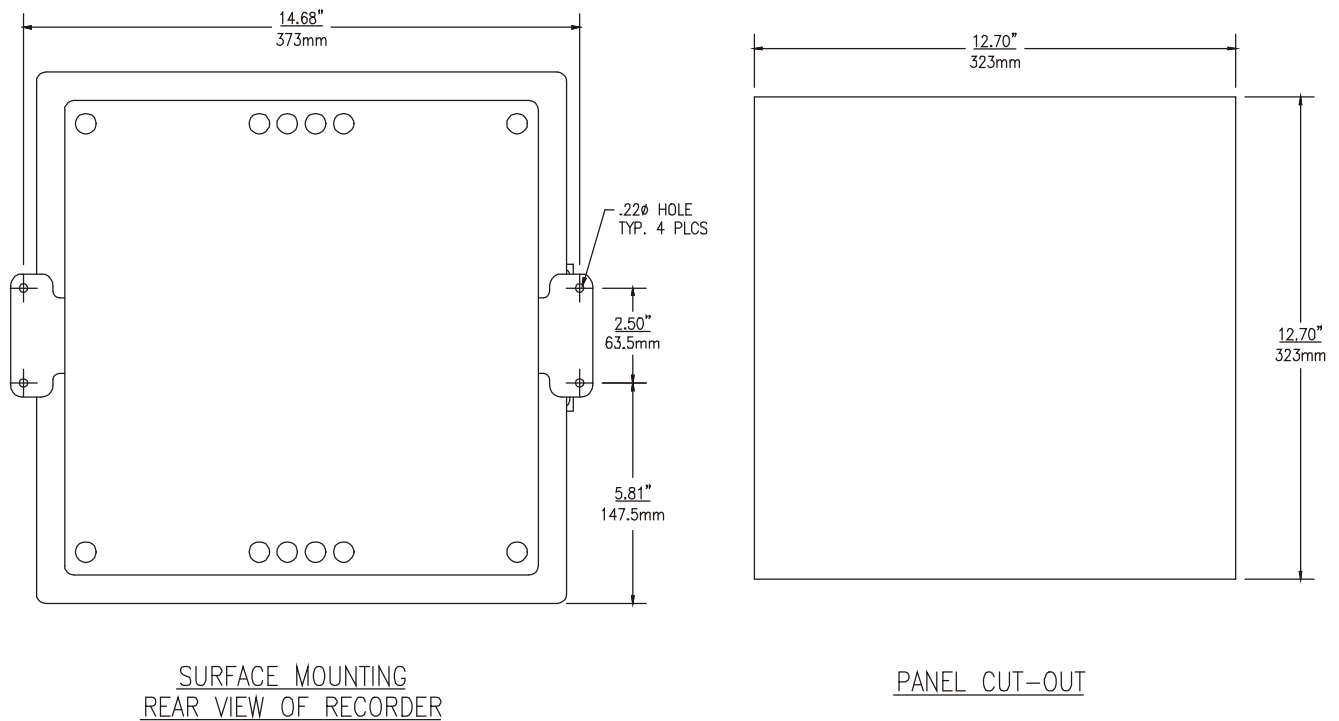

Figure 3 - Recorder Installation (ATI-0107)

Free chlorine sensors are best used in a constant head overflow chamber because variations in sample flow rate and pressure can cause unstable readings. When monitoring low concentrations (below 0.5 PPM), this method should always be used. Some applications, however, are much easier done using a submersible sensor. This method can sometimes be used where flow is reasonably constant, and hydraulic head does not vary appreciably. Chlorine sensors can never be used in completely stagnant conditions. A flow velocity of at least 0.3 feet per second is normally required for measurement. Any applications for a submersible free chlorine sensor should first be discussed with ATI. A trial of such installations may be necessary.

Mechanical installation of the flowcell requires that it be mounted to a wall or other convenient flat surface. Alternatively, the mounting holes on the plate will accommodate a 2" U-bolt for mounting the plate to a 2" pipe. Figure 4 shows the dimensions and mounting hole locations for the flowcell. Be sure to allow enough clearance on the left side of the flowcell for insertion and removal of the sensor. About 12 inches clearance is recommended.

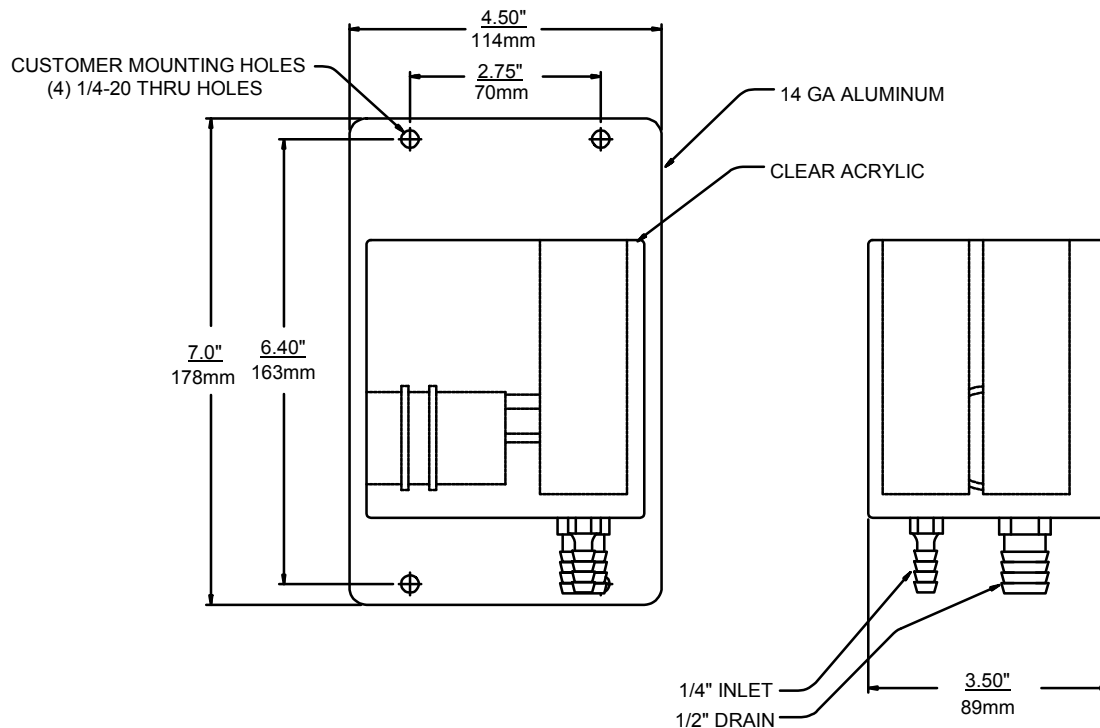

Figure 4 - Flowcell Dimensions (ATI-042)

Once mounted, inlet and drain connections must be made. The flowcell contains a 1/8" MNPT inlet connection and a 3/8" MNPT drain connection. Hose barbs for the inlet and drain connections are supplied with the flowcell for use with flexible tubing. The inlet hose barb is used with 1/4" I.D. tubing and the drain hose barb is used with 1/2" I.D. tubing.

Submersible sensors are mounted to a 1" pipe using a standard 1" PVC thread by thread pipe coupling. The mounting pipe can be secured to standard 1 1/2" pipe rail using a mounting bracket kit available from ATI (part number 00-0628) as shown in Figures 5 and 6.

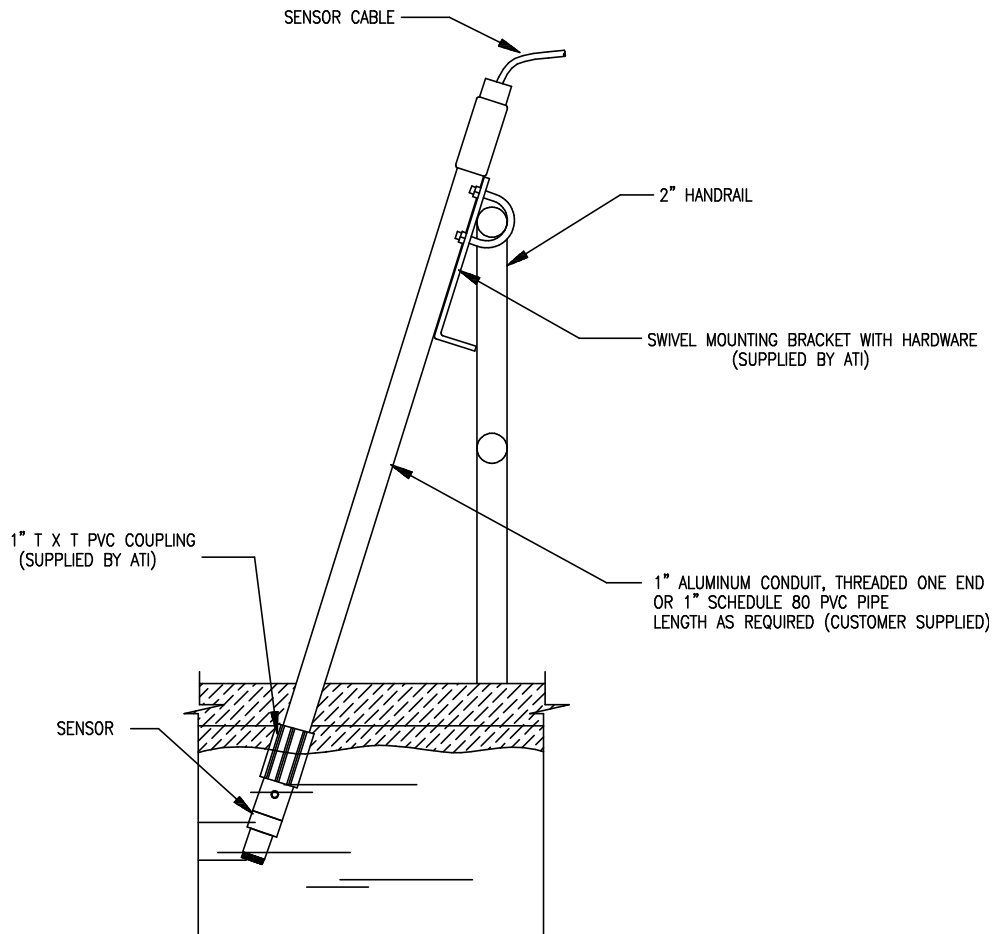

Figure 5 - Sensor Pipe Mount Installation (ATI-0155)

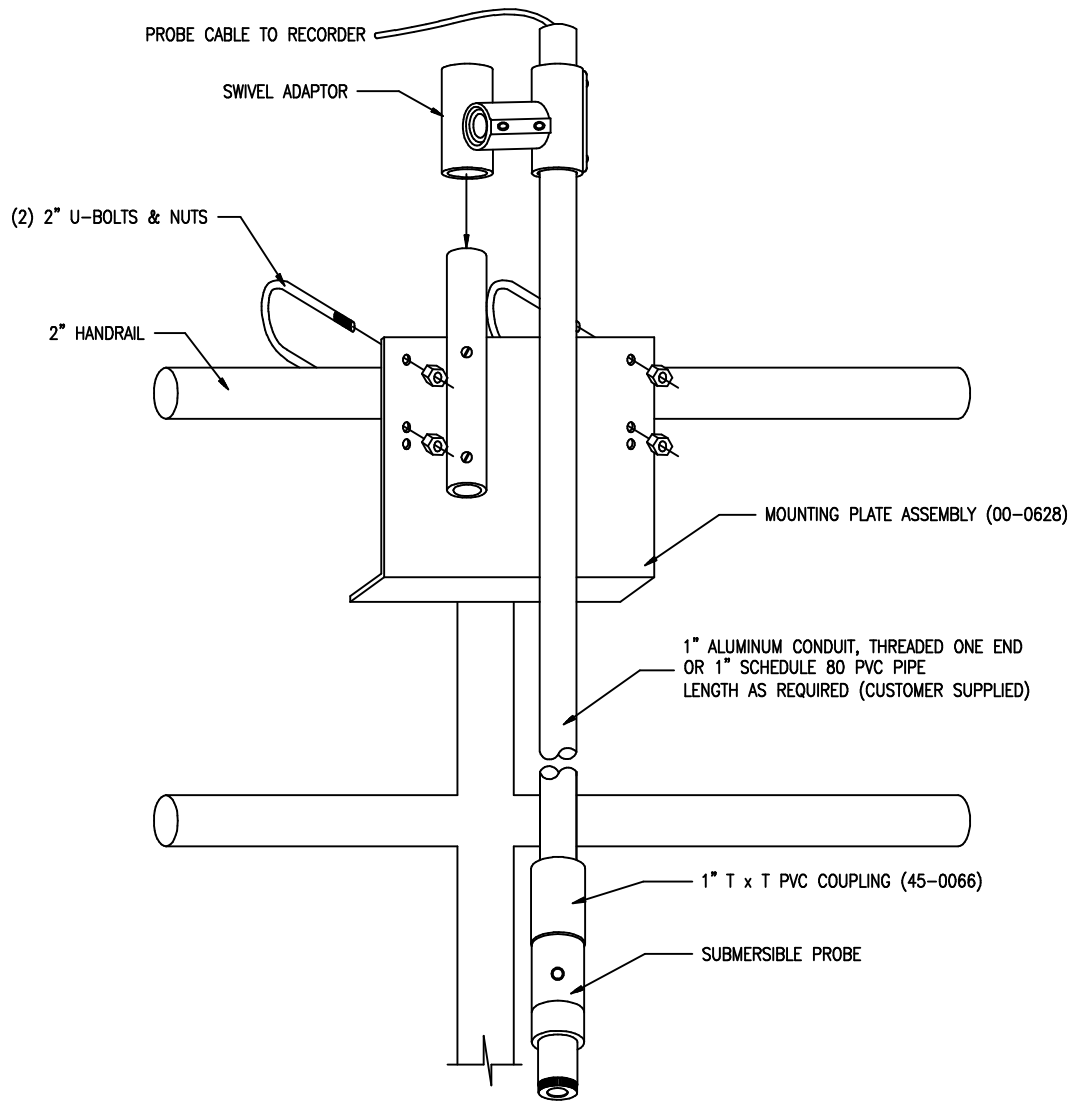

Figure 6 - Mounting Assembly Detail (ATI-0188)

ELECTRICAL CONNECTIONS

All electrical connections are made inside the recorder unit. Refer to Figure 7 below for the proper connections. A power cord is supplied with each unit for AC connection and a 5 conductor shielded interconnect cable is supplied for connection of the chlorine sensor to the recorder. Refer to Figure 8 for interconnection of a system with remote chlorine amplifier.

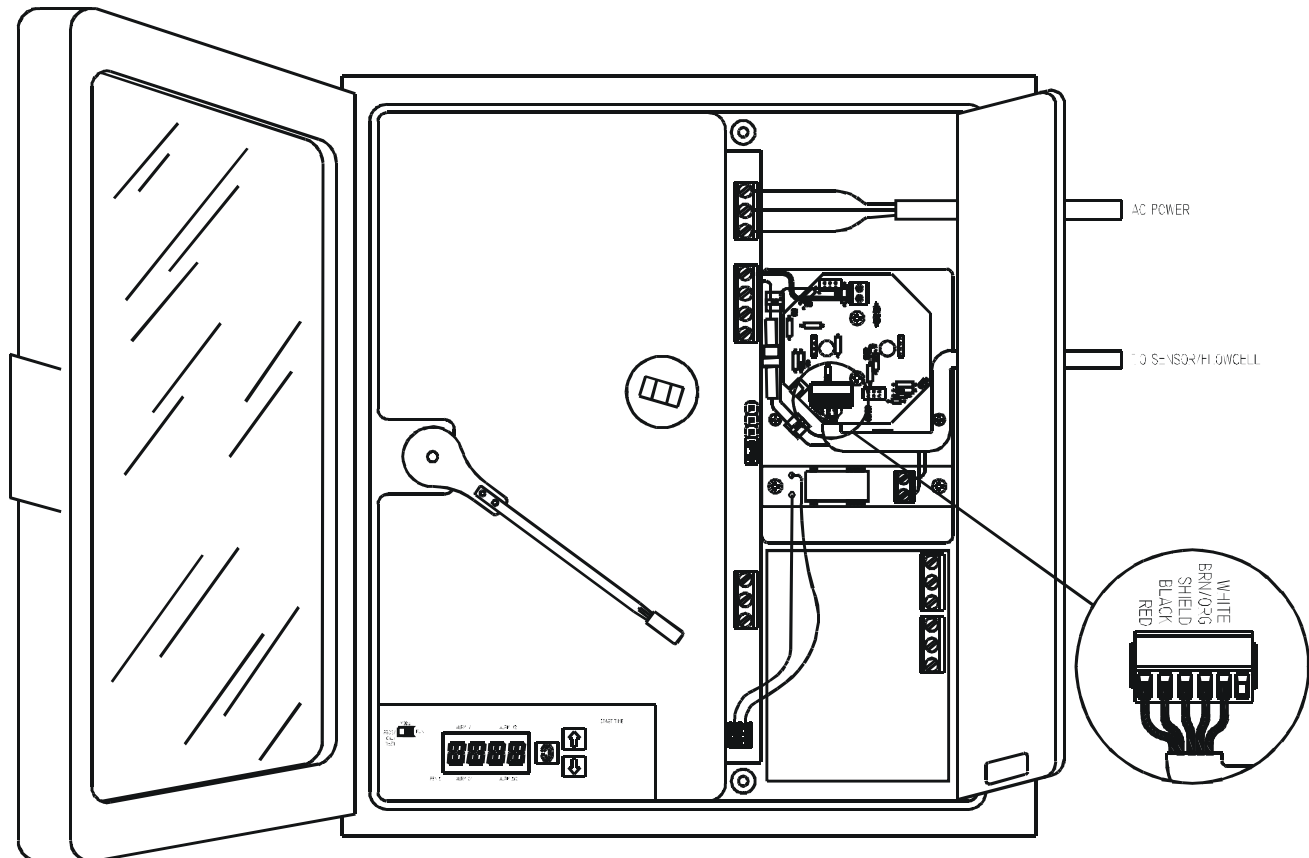

Figure 7 - Recorder Customer Connections with Internal Transmitter (ATI-0134)

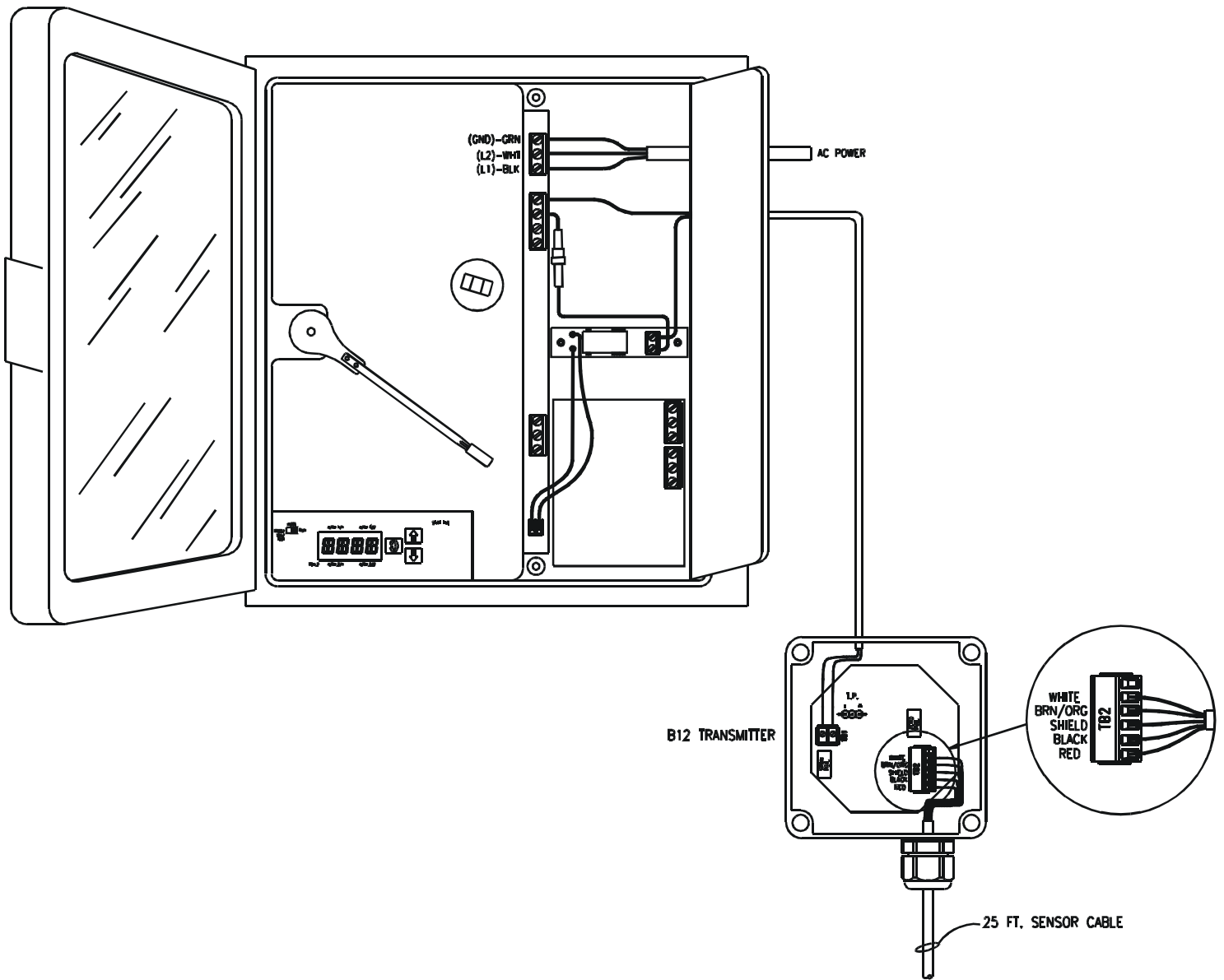

Figure 8- Recorder Customer Connections with Remote Transmitter (ATI-0135)

ATI Model B20/62 Free Chlorine Recorder

For installations where the sensor is to be located more than 25 feet from the recorder (max. 100 feet), a junction box must be used. The junction box is shown in Figure 9 and is supplied with a 1/2" conduit hub on one end and a sensor cable gland on the other end.

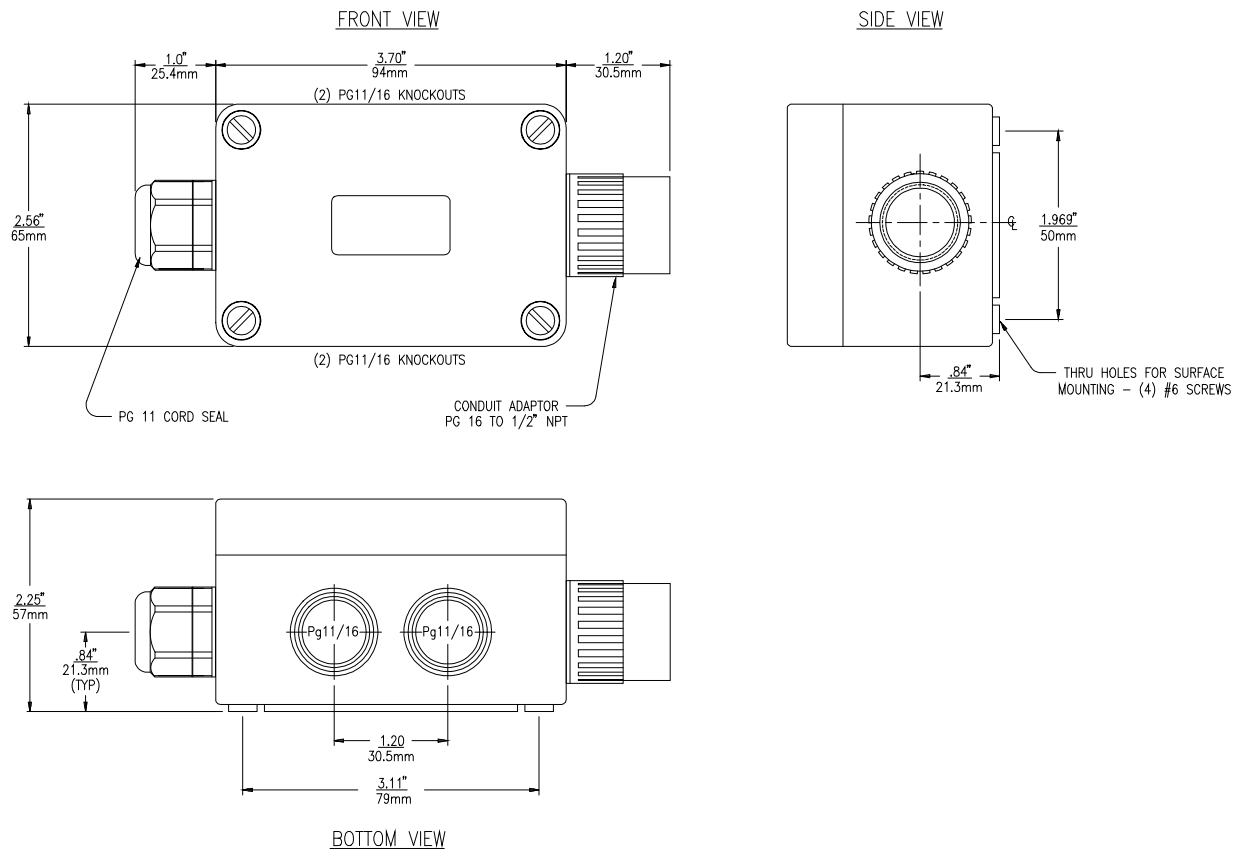

Figure 9 - Junction Box Dimensions (ATI-068)

Installation wiring for systems containing a junction box is shown in Figure 10.

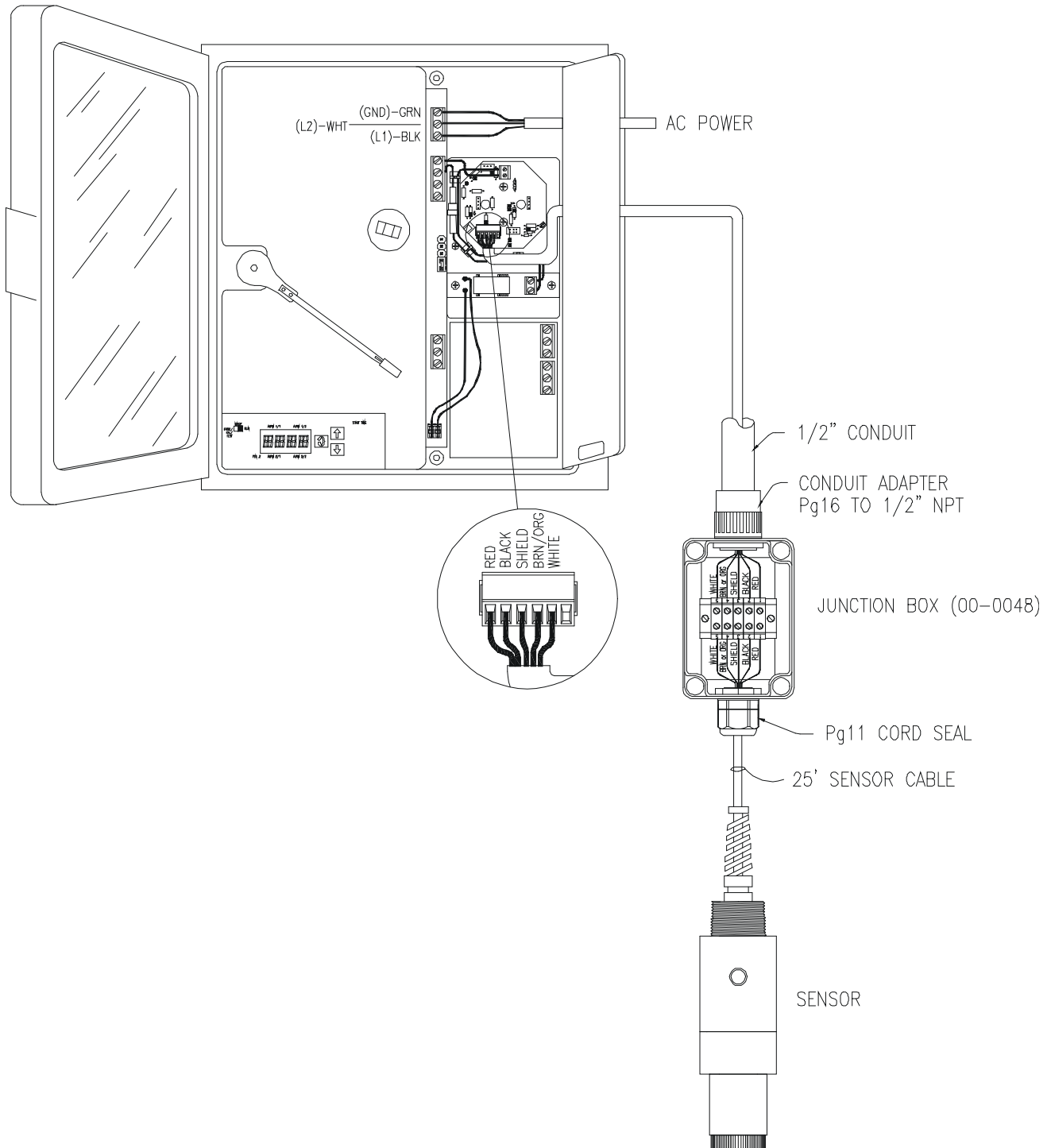

Figure 10 - Junction Box Interconnect Wiring (ATI-0137)

CHLORINE SENSOR ASSEMBLY

The chlorine sensor supplied with the B20 is shipped dry. It will not operate until it is prepared by adding electrolyte and a membrane. Preparation of the sensor for operation must be done carefully. The procedure should be done by a qualified technician, and it should only be done when the system is ready for operation. Until then, it is best to leave the sensor in the condition in which it is received. Refer to Figures 11 and 12 on the following page.

Follow the procedure below to prepare the chlorine sensor for operations:

1. Unscrew the electrolyte canister from the assembled sensor and also remove the vent screw from the side of the sensor body.
2. Remove the membrane cap from the bottom of the canister and discard the protective membrane. O-rings are contained in grooves on both the bottom and top of the canister. Be sure that these o-rings remain in place.
3. From the package of membranes supplied with the sensor, place a new membrane into the membrane cap. **The membrane is white in color and is separated from other membranes by a light blue paper spacer.**
4. Screw the membrane cap on to the canister until you feel the o-ring compress. Hand tight compression is all that is needed. Do not use tools to tighten. The membrane should be flat across the bottom of the canister without wrinkles.
5. Fill the canister with electrolyte until the level reaches the bottom of the internal threads.
6. Slowly screw the canister onto the sensor body. A small amount of electrolyte will run out of the hole from which the vent screw was removed. Place a paper towel around the sensor to absorb the electrolyte overflow. The electrolyte is harmless and will not irritate skin. Tighten the canister until the o-ring at the top of the canister is compressed. Once again, do not use tools to tighten.
7. Shake excess electrolyte from the vent hole on the side of the sensor and replace the vent screw.

The sensor is now ready for operation. The membrane should be stretched tightly across the tip of the sensor. When handling the assembled sensor, do not set the sensor on its tip or damage to the membrane will result. Severe impacts on the tip of the sensor from dropping or other misuse may cause permanent damage to the sensor.

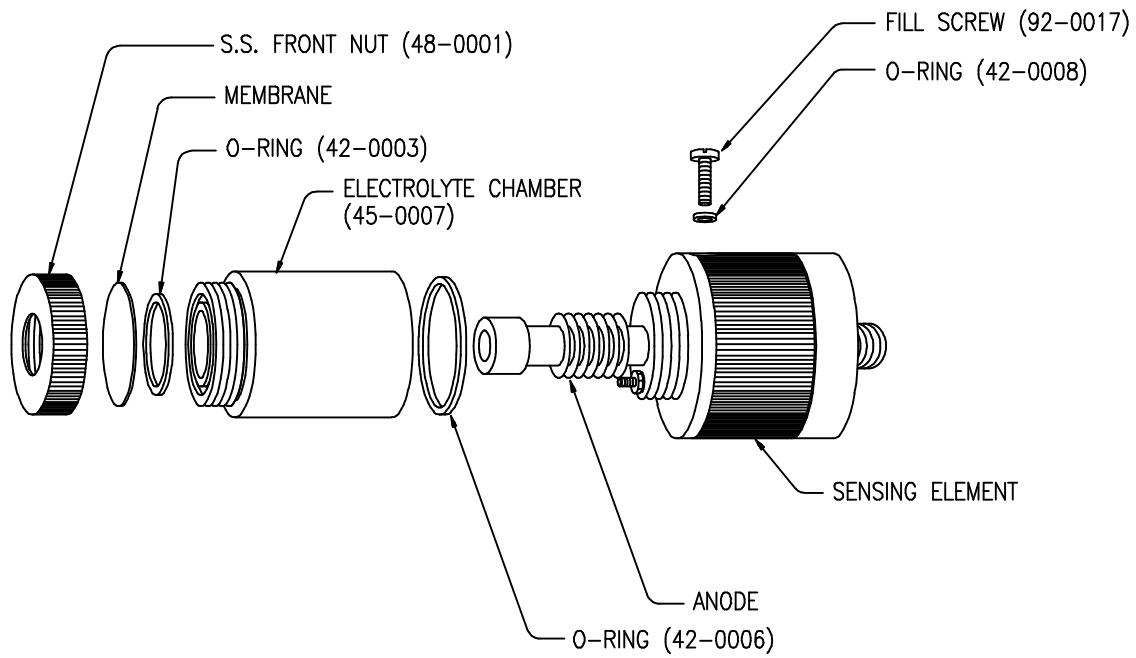

Figure 11 - Chlorine Flow Sensor Assembly (ATI-0246)

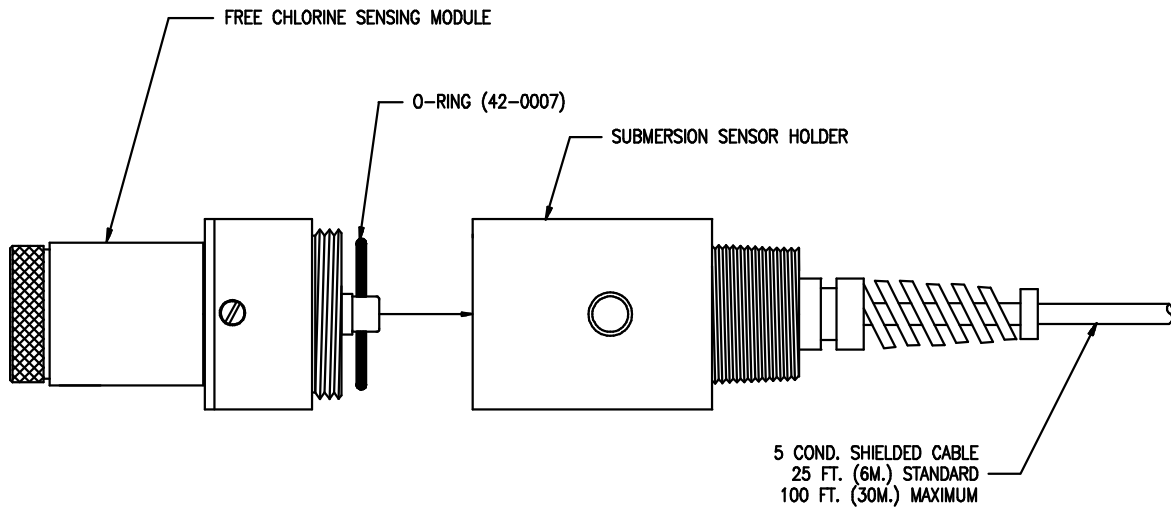

Figure 12 - Chlorine Submersible Sensor Assembly (ATI-0245)

RECORDER PROGRAMMING

Prior to operation, recheck electrical connections to be sure that everything is in accordance with customer connection diagrams. If everything is in order, power may be applied to the recorder. Note that the L1 or "hot" power connection is made to a terminal block containing a fuse. The fuse is held in by a lever connector which can be pulled up to disconnect power from the system.

After power has been turned on, the unit must be allowed to stabilize for at least 3 hours prior to calibration. This time period is primarily to allow the sensor time to come to a stable zero. Stabilization will occur whether the sensor is in unchlorinated water or installed in the flowcell with chlorinated water running through the flowcell. The simplest method is to place the sensor in the flowcell and allow normal sample to flow for 3 hours while the sensor stabilizes. Do not be concerned with the values being shown on the recorder or the display during this time.

Recorders are factory programmed for most of the variables required for operation. About the only programming that might be needed is setting chart speed, setting the alarm setpoints, and adjusting the operating range. These functions are described below.

Chart Speed Selection

All B20 chlorine recorders are factory set for 24 hour chart speed. However, the speed can be easily changed to 7 day rotation by a simple adjustment. To change chart speed, the unit must be put into the "program" mode. A "MODE" switch just to the left of the LED display must be put in the program position for changing chart speed. When the switch position is changed, "pro9" (this is suppose to indicate PROG or program mode) will appear on the display. Press the DOWN arrow once, then press the SCROLL key, press the DOWN key again, and then the SCROLL key again. The display will now indicate the current chart speed setting, normally 24 hours. Press the UP key twice and the display will indicate "7 day". If this is the only adjustment you intend to make, simply slide the switch back to the RUN position. If you want to set other parameters, press SCROLL, UP, and SCROLL again and your display will indicate PEN 1, which is the starting point for other adjustments.

Programming Digital Display Range

The digital display on the front of the recorder is programmed to display residual chlorine concentration in engineering units of PPM. The engineering units representing zero and full scale are set at the factory based on the operating range specified on your order. For example, if the order calls for a 0-2 PPM range, the display will be programmed to read 0.00 to 2.00 corresponding to the 4-20 mA signal coming from the internal transmitter. If a range change is desired, three programming variables must be adjusted, the decimal point location (dPOS), the full scale value (EUU), and the chart full scale value (CHUP).

NOTE: The recorder display is simply an indicator of the 4-20 signal coming from the transmitter. You must also recalibrate the transmitter in order to change the operating range of the system.

To change the recorder display scaling, start with the display indicating “prog” and press the DOWN key seven times. The display will indicate “dPOS”. Press the scroll key and the display will indicate the number of decimal places to be shown on the display. Normally, this value is 2, but can be changed if desired. Use the UP or DOWN keys to select the number of decimal places desired. Press SCROLL again and the display will indicate “EUU”.

The “EUU” routine allows adjustment of the full scale display, or the value that will be shown when the transmitter is at 20 mA. Press the SCROLL key and the current full scale value will be shown. Use the UP or DOWN key to change this value to your new full scale value. When adjusted, press the DOWN key and the display will indicate “EUL”.

The “EUL” routine adjusts the display value corresponding to 4 mA. This is factory set at zero, and should not normally be changed. Press the SCROLL key to verify that the value shown is zero. Then press SCROLL again and the display will indicate “ChUP”.

The “ChUP” routine programs the value that equates to the upper chart deviation. This value must be adjusted to the same value as that set in “EUU” above. Press the SCROLL key to view the current setting and use the UP and DOWN keys to adjust to the full scale value. When complete, press the SCROLL key and the display will indicate “ChLO”.

The “ChLO” routine, like the “EUL” routine above, should normally be set to zero. Press the SCROLL key to verify that this is the case. Then press SCROLL again to exit. Press the UP key twice and the display will return to “pro9”.

Alarm Hysteresis Adjustment

Alarm hysteresis is the change allowed between relay activation and deactivation around the alarm setpoint. It is a good idea to program a small amount of hysteresis to avoid relay chattering when the measured value is close to an alarm setpoint. For example, a high alarm with a setpoint of 1.00 PPM will energize at 1.00 PPM and deenergize at .99 PPM. If the measurement is changing back and forth from 1.00 to .99, the relay will open and close rapidly, which could result in relay failure. Adding hysteresis of 0.03 PPM will require the value to fall below .97 before the relay deactivates, avoiding relay chatter.

Alarm hysteresis is factory set at 0.05 PPM. If you wish to increase or decrease that value, start from the “pro9” display and press the down key twelve times. The display will show “HYSt”. Press the SCROLL key and the display will show the current setting. Use the UP or DOWN key to adjust as desired. When done, press SCROLL again and then press the UP key twice to return to “pro9”.

Alarm Setpoint Adjustment

Alarm setpoints are adjusted while the recorder is in the RUN mode. With the unit indicating chlorine concentration, press the SCROLL key. The display will indicate “CC”. Press SCROLL again and the display will indicate the current setpoint for alarm 1. The red alarm indicator next to ALARM 1/1 will be flashing. Use the UP and DOWN keys to adjust to the desired value and then press SCROLL. The display will then indicate the alarm 2 setpoint and the red indicator next to ALARM 1/2 will be flashing. Adjust alarm 2 in the same manner and press the SCROLL key to return to the normal chlorine display.

CHART SETUP

Installation of chart paper and pens is simple. The directions below describe each procedure. A label on the lower right portion of the front panel provides a simplified description of the proper procedure.

Chart Paper Installation

To install chart paper in the recorder, it is best to move the pen to the edge of the recorder paper. This is done automatically. Press the SCROLL key once and "CC" will appear on the display. Press DOWN and the chart pen will move to the edge of the paper.

Once the chart pen is out of the way, flip up the chart retainer so it is straight up and remove the old chart. Place a new chart on the spindle and line up the time line on the chart to match the current time. The "start time" line is located just to the right of the UP key. Be sure that the chart is under the 3 edge guides so that the paper stays flat. Then push the retainer back to its down position and press the DOWN key. The pen will move back to the position determined by the current input value.

Pen Installation

Recorder pens snap onto the pen arm of the recorder. Recorders are shipped from the factory with the pen installed and a rubber cap over the tip of the pen. A tab at the back of the pen is used to simply lift the pen out of its holder. To remove, pull up on the tab at the back of the pen. Hold the pen arm just behind the pen to avoid bending the arm. To install a new pen, place the end of the pen against the v-groove at the end of the pen arm and press the back of the pen into the holder.

OPERATION

Once the sensor has had sufficient time to stabilize, the zero and span of the system must be set. Establishing a stable zero is critical to the proper operation of the recorder and should always be done before setting the span. The zero and span potentiometers used for adjustment of the B20 recorder are located on the transmitter circuit board located behind the right half of the recorder chart plate. See Figure 7 for the location of the transmitter. Figure 13 below shows the position of the zero and span potentiometers on the transmitter board. They are the same whether the transmitter is internal to the recorder or external.

While it is not necessary to remove the chart paper during calibration, the chart paper must be moved out of the way to open the right hand compartment where the transmitter is located. Pull the chart paper out of the two edge guides on the right compartment and loosen the two retaining screws that secure this panel. Open the panel to allow access to the transmitter adjustments. If your system is supplied with a remote transmitter, this is not necessary as the adjustments will be made in the remote transmitter.

ZEROING THE SYSTEM

To establish a stable system zero, proceed as follows. The steps below assume that the sensor has been prepared in accordance with the **Chlorine Sensor Assembly** section earlier in this manual. Note that the 2-3 hour waiting time in step 2 below is not required if the recorder has been running for 3 hours prior to zeroing. If the unit has been running, the sensor will normally return to a stable zero within 15 minutes.

1. Connect the sensor to the electronics by plugging the cable plug into the receptacle on the top of the sensor. Submersible sensors will normally be permanently wired to the recorder.
2. Place about an inch of water in a small beaker or other convenient container and immerse the tip of the sensor. The water used need not be distilled, but it must not contain residual chlorine. For submersible sensors, submerge the entire sensor in a bucket of unchlorinated water. Allow the sensor to sit undisturbed for at least 2-3 hours.
3. Observe the value indicated on the LED display. The display should be fairly close to 0.00. Use the zero potentiometer on the transmitter board to adjust the LED display to 0.00. If your system is supplied with the optional remote amplifier, connect a DVM to the test points indicated in Figure 14. Adjust the zero potentiometer until the voltage on the DVM reads .040V.

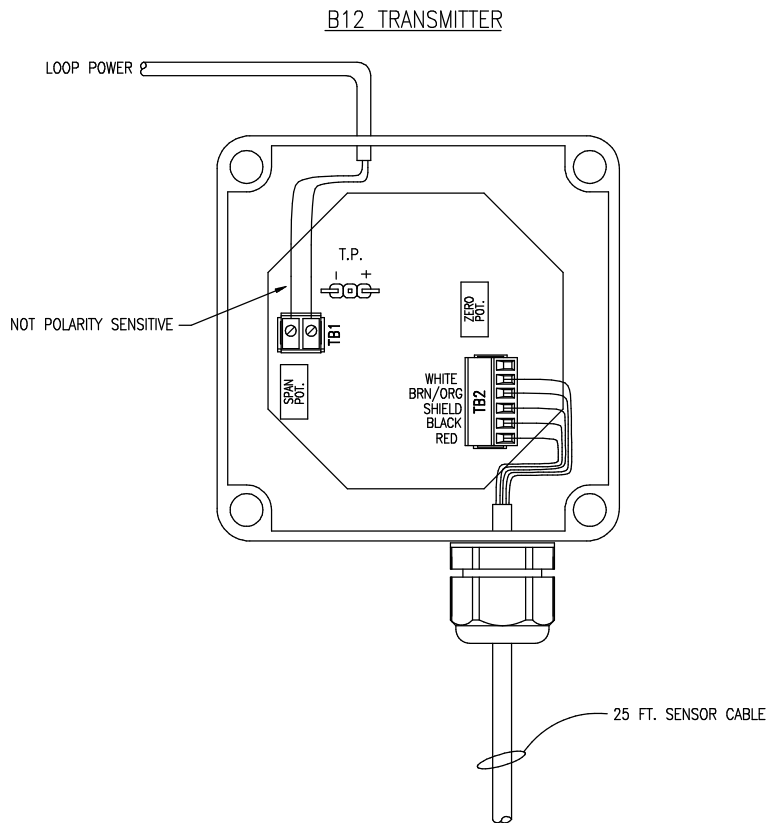

Figure 13 - Transmitter Test Points, Zero, & Span Potentiometers (ATI-085)

FLOW SYSTEM STARTUP

The free chlorine recorder should be calibrated while operating on a chlorinated sample stream. Place the system into operation as follows:

1. Place the previously zeroed sensor into the sensor chamber of the flowcell assembly. The sensor is inserted into the side of the flowcell and is sealed in place with a double o-ring. The o-rings are lubricated at the factory to allow the sensor to slide smoothly into place. If insertion becomes difficult, use a small amount of silicon grease to lubricate the o-rings.
2. Turn on the inlet water flow to the flowcell and adjust the inlet flowrate so that water is overflowing from the inlet chamber. The best performance will be obtained when some water is always overflowing. This maintains constant flow and pressure on the sensor at all times.
3. Allow the system to operate undisturbed for 30-60 minutes. Assuming the water contains free chlorine, the recorder will be indicating positive values. If the chlorine residual in the system is stable, the value on the recorder will increase to some PPM value and remain at that level. At that point, calibration may be completed.

CALIBRATION

Calibration of the Free Chlorine Recorder must be done against a laboratory measurement on the same sample that the sensor is measuring. A sample should be collected from the inlet line feeding the flowcell and quickly analyzed for free chlorine. When calibrating, it is best to have a reasonably high concentration of free chlorine in the system. The higher the value, the smaller will be the calibration errors caused by errors in the laboratory analytical procedure. It is generally preferable to calibrate at values above 0.5 PPM to reduce calibration errors. If possible, the amperometric titration procedure for free chlorine should be used as the reference method. Alternately, the DPD colorimetric method may be used provided that the sample contains mainly free chlorine, with no more than a trace of chloramines. The DPD procedure will indicate high values for free chlorine if a large amount of monochloramine is present in the sample.

Calibrate the system as follows:

1. With the recorder indicating a stable free chlorine value, collect a sample from the inlet line and determine the free chlorine concentration using an appropriate laboratory method.
2. Using the span potentiometer (see Figure 13), adjust the LED display value to the value measured by the laboratory test. If your unit is supplied with a remote transmitter, use the Test Point Voltage equation to calculate the proper voltage at the test points of the transmitter. The transmitter output is between .040V and .200 V, proportional to span at the test point.

$$\text{Test Point Voltage} = [.160V \times (\text{Free Cl}_2 \text{ Value} \div \text{Full Scale Span})] + .040V$$

3. After adjustment, carefully close the transmitter compartment and put the chart paper back into the edge guides.

MAINTENANCE

The B20/62 Free Chlorine Recorder will generally provide unattended operation over long periods of time. With proper care, the system should continue to provide measurements indefinitely. For reliable operation, maintenance on the system must be done on a regular schedule. Keep in mind that preventive maintenance on a regular schedule is much less troublesome than emergency maintenance that always seems to come at the wrong time.

SENSOR MAINTENANCE

Virtually all of the maintenance required for operation of the Chlorine Recorder is sensor related. The electronics are generally trouble free. They are burned in at the factory and will likely have a problem only if random component failure occurs.

Sensor maintenance is required for accurate measurements. The primary requirement is simply to keep the sensor membrane clean. The membrane is a microporous polymer that is resistant to anything that will be encountered in water streams. However, deposits can form on the surface or in the pores of the membrane, and these deposits will reduce the sensitivity. Certain constituents in water, mainly iron and manganese, will form precipitates when the water is chlorinated. These precipitates can sometimes form a coating on the membrane.

Because membranes are microporous, they can be relatively difficult to clean effectively. Immersing the tip of the sensor in 1N nitric acid solution will sometimes remove deposits that cause low sensitivity, but this is not always the case. The recommended practice is to simply replace the membrane when it becomes fouled. To change a membrane, follow the Sensor Assembly procedure on page 14 of this manual. Do not reuse the electrolyte from the sensor when changing a membrane. Always refill with fresh electrolyte. The electrolyte is stable and does not have a limited shelf life.

Even if no buildup is apparent on the membrane, it should be changed on a regular schedule. The recommended membrane change interval is every 3 months. For high purity water applications, this can probably be extended if desired, but a more frequent changing interval is a small price to pay for avoiding membrane failure at the wrong time.

While the sensor is disassembled for membrane changing, examine the condition of the o-rings on both ends of the electrolyte canister. If the o-rings show any signs of damage, replace them with new ones from the spare parts kit. It is good practice to change these o-rings once a year, regardless of their condition.

FLOWCELL MAINTENANCE

The maintenance on the flowcell is simply to keep it clean. The flowcell is clear to assist operators in examining the condition of the sensor without interfering with operations. Deposits on the flowcell will make this more difficult. The flowcell may be cleaned by wiping or by washing with detergents or dilute acids. Do not try to clean with solvents as the acrylic may craze or crack.

Change the o-ring in the flowcell yearly or if any damage is observed. If insertion of the sensor into the flowcell becomes difficult, use silicon grease to lubricate the o-rings that hold the sensor in place. Use only enough grease to provide surface lubrication. Excess grease could foul the sensor membrane.

SPARE PARTS LIST

<u>PART NO.</u>	<u>DESCRIPTION</u>
00-1094	Free chlorine recorder with display (internal transmitter)
00-1096	Recorder with display (external transmitter)
00-0321	Remote free chlorine transmitter
01-0049	Remote free chlorine transmitter circuit board
01-0063	Internal free chlorine transmitter circuit board
03-0029	Sensor interconnect cable, 25 ft.
00-0574	Residual chlorine sensor, flowcell type
02-0057	Sensing Element, flowcell sensor
00-0577	Residual chlorine sensor, submersible, with 25' cable
02-0021	Sensing Module, submersible sensor
02-0017	Sensing Element, submersion sensor
02-0058	Submersion sensor holder
45-0007	Electrolyte chamber
48-0001	Membrane holder, type 316 stainless steel
45-0010	Membrane holder, noryl
05-0005*	Free chlorine Membranes, pkg. of 10
05-0004*	Sensor screw and o-ring kit (for flowcell sensor)
05-0010	Sensor screw and o-ring kit (for submersible sensor)
09-0011*	Free chlorine electrolyte, 4 oz (120 cc)
00-0043	Flowcell assembly with mounting plate
42-0014*	Flowcell o-ring (each)
55-0035*	Pens (Pkg. 5)
55-0039*	Charts, 2 sided 24hr/7day

Note: Items marked with an asterisk (*) are recommended spare parts.