

# Building Sustainability Management

Solutions for Building Management and Optimization

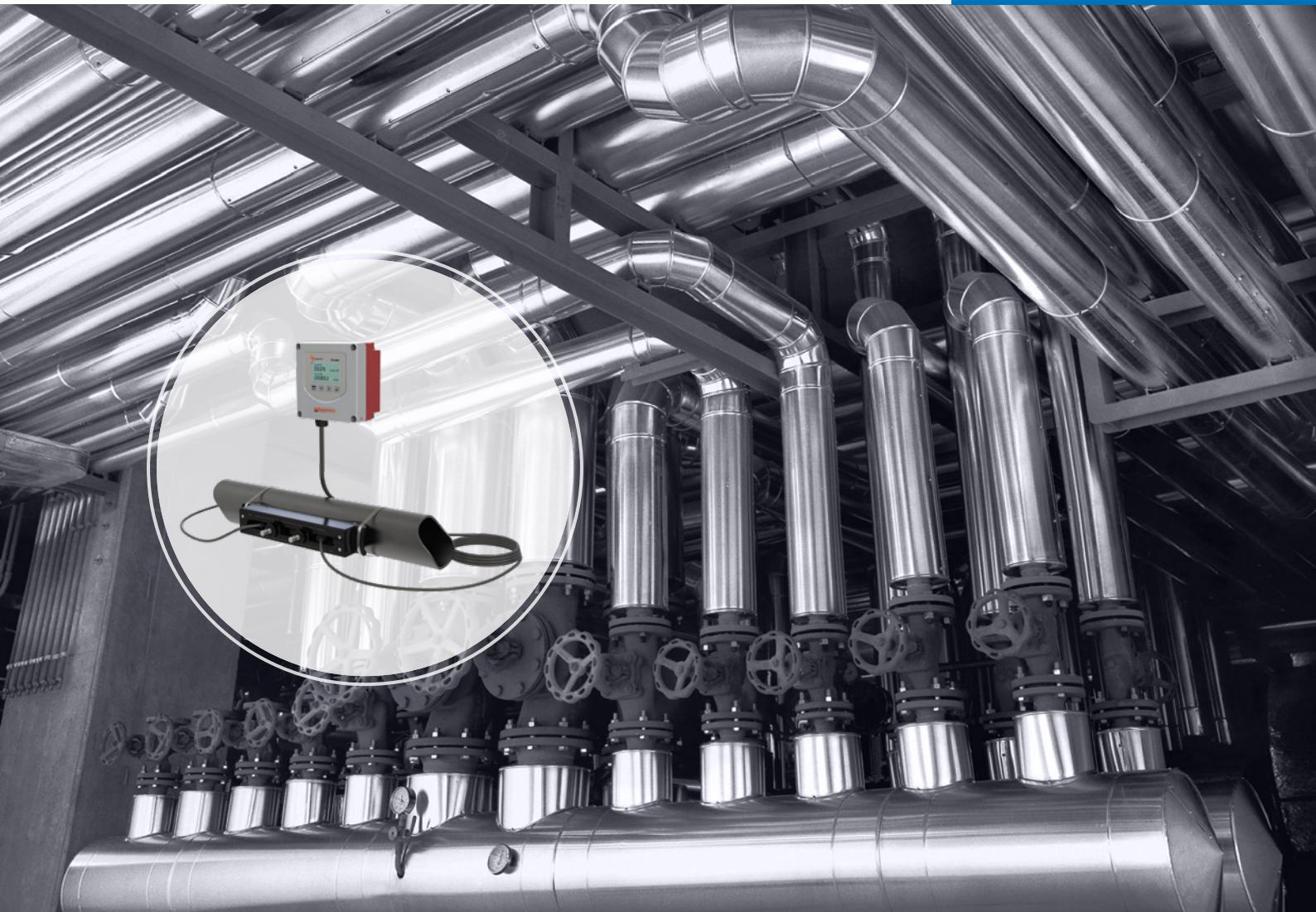



# Content

<b>Company</b>	<b>4</b>	<b>Products</b>	<b>22</b>
Sustainability	4	Dynasonics® UHC 100	23
Measurement	5	Dynasonics® TFX-5000	24
Solutions for Building Management	6	Dynasonics® U500w	25
		Dynasonics® TFX-500w	26
<b>Heating and Cooling Systems</b>	<b>10</b>	Impeller SDI	27
Hydronic Heating and Cooling	11	ModMAG® M1000 & M2000	28
Flow Meter Overview	11	ModMAG® M5000	30
Measurement Location	12	Impeller 380 Btu Series	31
Steam Heating	14	Impeller 220 Series	32
Flow Meter Overview	14	Recordall® Disc Meters	33
Measurement Location	14	Recordall® Turbo Meters	34
<b>Water Measurement and Optimization</b>	<b>15</b>	Vortex VN2000	35
Effective Water Measurement for Smarter Buildings	16	Preso® Cone Meter	36
Flow Meter Overview	17		
Optimization	18		
Water Measurement	19		
Irrigation	20		
Flow Meter Overview	20		
Measurement Location	20		
Wastewater	21		
Flow Meter Overview	21		
Measurement Location	21		

# Company

## Sustainability

### Message from the President

Sustainability has been vital to Badger Meter since our founders invented the frost-proof water meter in 1905. That invention helped people measure their water use even during the harsh months of winter in Wisconsin. Today, our smart metering and flow instrumentation solutions help municipal utilities and building management throughout the world measure virtually anything that moves through a pipe. In the process, we deliver long-term value to our customers, employees and investors by providing solutions that help manage and conserve the world's most precious natural resources.

As a corporation, Badger Meter pursues continuous improvement initiatives in three major sustainability categories:

- **OUR PRODUCTS** help save water and other natural resources through our highly accurate metering and analytics solution.
- **OUR OPERATIONS** include socially responsible supply chain practices and responsible use of resources in the management of our facilities.
- **OUR PEOPLE** are a major source of strength and together we strive to cultivate and maintain a healthy, productive and engaged workforce while contributing to the communities and industries in which we are a part.

We are proud of our success and the progress we continue to make. Our sustainability team and the company as a whole remain dedicated to helping our customers efficiently use resources, to practice what we preach in our operations, and through our dedicated and engaged workforce we continue to make our company and the world a more vibrant place.

All the best,

Ken Bockhorst  
Chairman, CEO and President - Badger Meter





# Measurement

## Actionable Intelligence for Buildings

You and your customers expect peak performance every day year-round and optimizing system performance allows the building to respond to changing occupant and environment demands and to manage costs. Badger Meter products provide the actionable intelligence for property managers to control, manage and optimize their facilities.

Adjusting building automation and water delivery systems to accommodate changes in usage, occupancy and facility age allows facilities to ensure occupant comfort while balancing costs, quality, and extending the useful life of older systems.

With a broad portfolio of technologies, Badger Meter provides solutions for every phase in a building's lifecycle from new construction to retrofit. A variety of installation styles and options means that Badger Meter delivers solutions specific to your building's needs.

Badger Meter has the measurement solutions you need for:

- Water delivery
- Heating and cooling systems
- Wastewater collection
- Water safety and sustainability

### Product solutions of Badger Meter

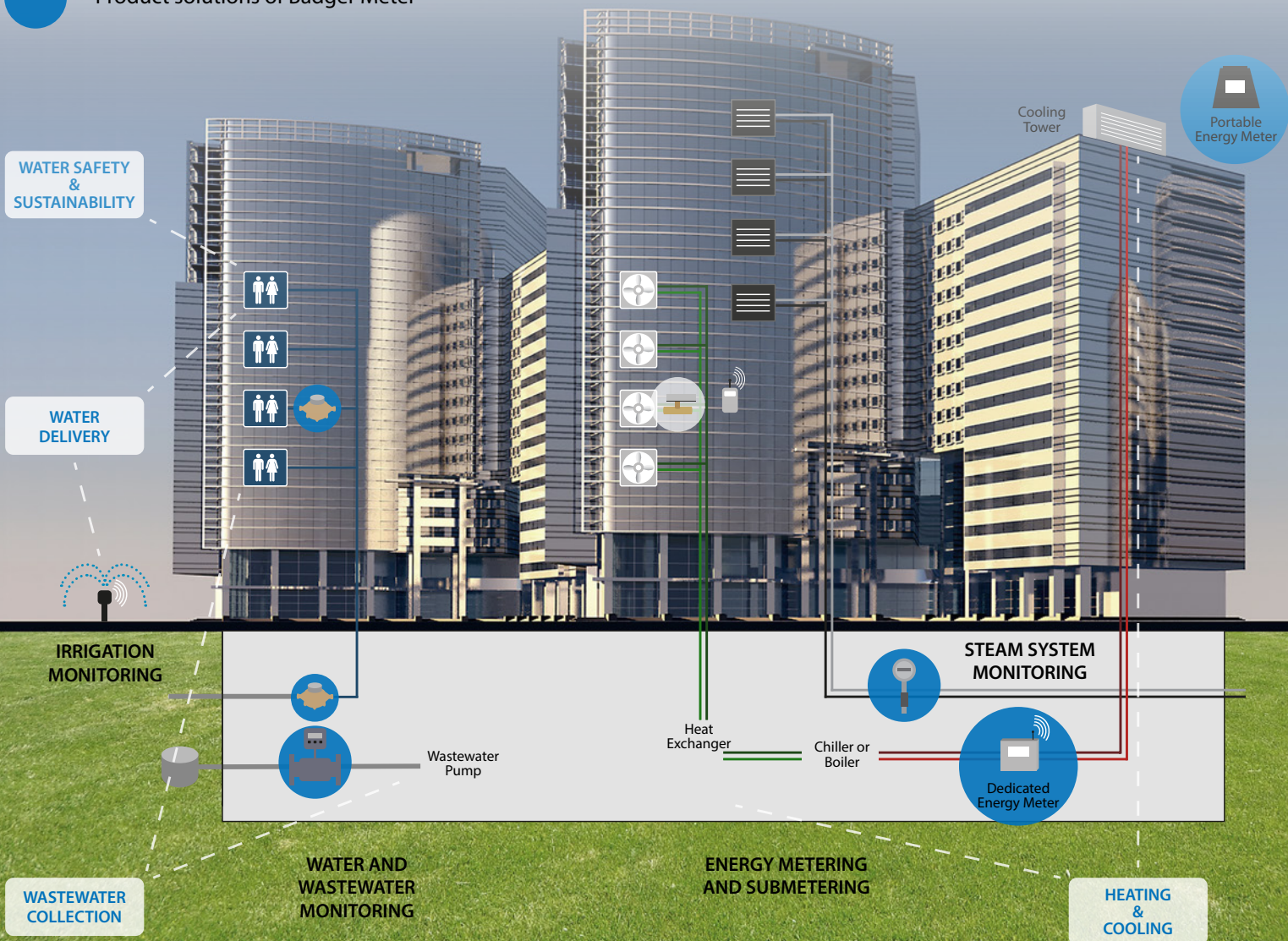

# Solutions for Building Management

Technology which measures your building resources

## ModMAG® M2000



Electromagnetic flow meter

Features:

- Dual Hastelloy C electrodes come standard
- Bi-directional flow measurement sensing and totalization
- Digital and analog outputs
- Empty pipe detection
- Cost-effective

## Dynasonics® TFX-5000



Transit time ultrasonic flow and energy meter

Features:

- Installs without shutting and draining system
- Large, bi-directional flow measuring range
- Data log up to 8 records
- Water-glycol and energy

## Dynasonics® U500w<sup>(1)</sup>



Transit time ultrasonic water meter

Features:

- Four sizes and lay lengths
- Completely submersible IP68
- Minimum extended low-flow rate lower than typical positive displacement meters
- Simplified one-piece electronic meter and register that integral to the meter body

## Dynasonics® TFX-500w



Transit time ultrasonic Clamp-on water meter

Features:

- Low installation costs
- Non-invasive clamp-on flow meter
- Measures flow rate, total and velocity of water flow
- Set up through keypad interface and SoloCUE® software

## ModMAG® M5000



Electromagnetic flow meter

Features:

- Battery-powered meter
- Internal datalogger
- Strong battery life
- Excellent repeatability
- Cost-effective

## Dynasonics® UHC 100



Ultrasonic heat meter and cooling energy meter

Features:

- Records energy usage
- EN1434, Canada approvals
- No straight sections required
- Power supply options: Battery / External

<sup>(1)</sup> Product available in the Americas only

### Impeller SDI



#### Insertion flow sensor

##### Features:

- Low installation costs
- Single direction powered insert with raw, scaled pulse and analog output
- Bi-direc. powered insert with analog and scaled pulse output
- Battery powered insert with a local and remote display and scaled pulse output

### Impeller 380 Btu Series

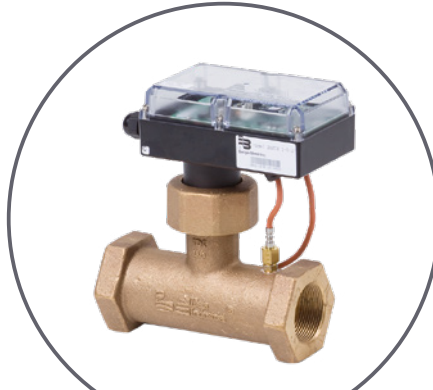

#### Flow sensor with Btu transmitter

##### Features:

- Single direction powered insert BACnet or Modbus RS-485 communications protocols or a scaled pulse output
- Flow Rate, Flow Total, Energy Rate, Energy Total, Temp 1, Temp 2, and Delta T can all be transmitted on the RS-485 connection

### Impeller 220 Series



#### Flow sensor

##### Features:

- Six-bladed impeller design with a proprietary, non-magnetic sensing mechanism
- Sensor electronics easily removed from tee
- Digital signal easily interfaced with transmitters, monitors or PLCs

### Recordall® Disc Meters



#### Nutating disc water meter

##### Features:

- Delivers precision accuracy with extended flow ranges
- Light weight
- Magnetic coupling
- Output: Pulse, 4-20mA, local read, etc...
- Low maintenance and long life

### Recordall® Turbo Meters <sup>(1)</sup>



#### Industrial turbine meter

##### Features:

- Direct coupled turbine based on an exclusive "floating rotor" design that reduces bearing friction and associated wear and tear
- Low pressure loss for improved system efficiency

### Vortex VN2000



#### Vortex meter

##### Features:

- Hot tap or direct insertion
- Steam or wet gases/air
- High flow ranges
- Large pipe sizes
- Cost-effective
- Low installation costs

<sup>(1)</sup> Product available in the Americas only



**Preso® Cone Meter**

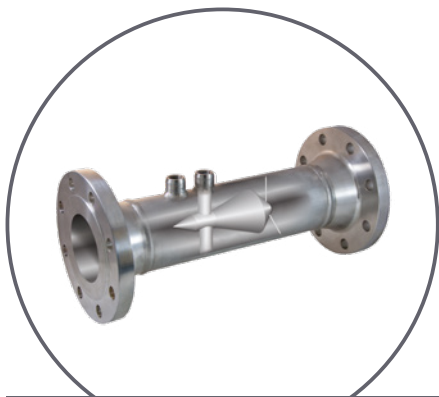

Cone differential pressure flow meter

Features:

- Little or no straight run piping requirements
- No additional flow conditioning devices needed
- Low maintenance and long life
- Steam measurement

**FC-5000 Btu Monitor**



Compatible with Impeller SDI and ModMAG® M2000

Features:

- Scaled pulse output
- Communication via EIA-485 Modbus
- Control panel mounted or wall mounted

**212 Heat Calculator**



Compatible with Impeller SDI and ModMAG® M1000/M2000

Features:

- 4-20 mA output option
- Communication via M-Bus and Modbus RTU RS 485
- Control panel mounted or wall mounted
- Approved for EN1434

**About Install Style**

Style	+ Pros	- Cons
Inline	<ul style="list-style-type: none"> <li>• The best accuracies and repeatabilities</li> <li>• Wider flow turndown ranges with more low-flow measurement capabilities</li> </ul>	<ul style="list-style-type: none"> <li>• Most labor intensive to install</li> <li>• Requires process shutdown and pipe draining to install (smaller diameter pipes may freeze)</li> </ul>
Insertion	<ul style="list-style-type: none"> <li>• Covers multiple pipe sizes</li> <li>• Less costly to install than an inline meter</li> <li>• Some models can be inserted into an active pipe (e.g. hot tap)</li> </ul>	<ul style="list-style-type: none"> <li>• Lower accuracy than inline</li> <li>• Flow profile dependent</li> </ul>
Clamp-on	<ul style="list-style-type: none"> <li>• Covers multiple pipe sizes</li> <li>• No plumbing skills required</li> <li>• Non-invasive flow meter</li> <li>• Low installation costs</li> </ul>	<ul style="list-style-type: none"> <li>• Lower accuracy than inline</li> </ul>



## Turn your Data into Proactive Intelligence

The AquaCUE® Flow Measurement Manager cloudbased software suite offers a wide choice of managed, traditional fixed network, mobile and consumer engagement solutions to meet your meter reading and reporting needs.

Increasingly, facility and sustainability managers are looking for ways to understand and monitor their water operations, improve inefficiencies, and address equipment problems and wasteful behavior. Sub-metering throughout a facility, property, or campus empowers personnel to make more knowledgeable decisions for more efficient use of valuable fluid resources.



### Benefits

#### Increased Visibility Through Analytics:

Provides proactive intelligence for optimal water management – faster leak detection, revenue management, water conservation, clarity and easier data collection for compliance reporting.

#### Enhanced Customer Service:

Advanced user profile and anomaly trending, combined with a cloud-based website and smartphone/tablet apps, allow you to gain a greater understanding of consumption patterns to quickly resolve or prevent related issues.

#### Focus on Water Management:

Built to minimize your deployment and system maintenance, we provide the hosted software platform, system maintenance and software support.

#### Future-Proof Technology:

Receive the cloud-based AquaCUE® software suite with regular updates.

# Heating and Cooling Systems

Heating and cooling systems exist to deliver thermal comfort and acceptable indoor air quality within reasonable installation, operation, and maintenance costs. In facilities that contain computer data centers, HVAC systems deliver the cooling required to maintain critical 24-7 operations.

HVAC systems can be designed as individual systems for individual buildings or as a larger district network that delivers heating and/or cooling to multiple buildings. District heating and cooling networks provide an economy of scale that is often not as viable for individual buildings.

All heating and cooling systems are comprised of:

- Heat generation or elimination, e.g. a boiler or chiller
- Distribution of the heat or chilling via water, steam (heat only), or air
- Consumption of the heating or cooling by a tenant, zone, or department

Measurement of key system parameters is critical to optimize operation and continuity of service. When buildings convert from constant heating/cooling to as-needed operation to reduce energy costs and provide a more consistent level of comfort, measurement is an essential part of system feedback loops.



**Hydronic Energy Measurement**



**Water Measurement**



**Steam Measurement**

# Hydronic Heating and Cooling

Hydronic, water-based, systems minimize energy usage, deliver more even heating/cooling, and are compatible with a wide variety of energy sources to heat or cool the liquid. Hydronic systems are one of the most popular methods used in district heating and cooling networks as well as in many individual systems.

Because hydronic systems use water which evaporates, and can be prone to mineral build-up, it is necessary to add and strategically eliminate water during system operation. Excessive amounts of added water, known as make-up water, are often indicative of leaks or stuck valves, which in turn correlate to water damage or water waste.

**WITH EVERY HYDRONIC ENERGY SYSTEM WE MEASURE:**

1. Energy at each boiler, chiller or cooling tower to determine system efficiency.
2. Energy at each tenant, zone or apartment to determine cost allocation and distribution network load balancing.
3. Make-up water.
4. Wastewater from system blowdown.

## Flow Meter Overview

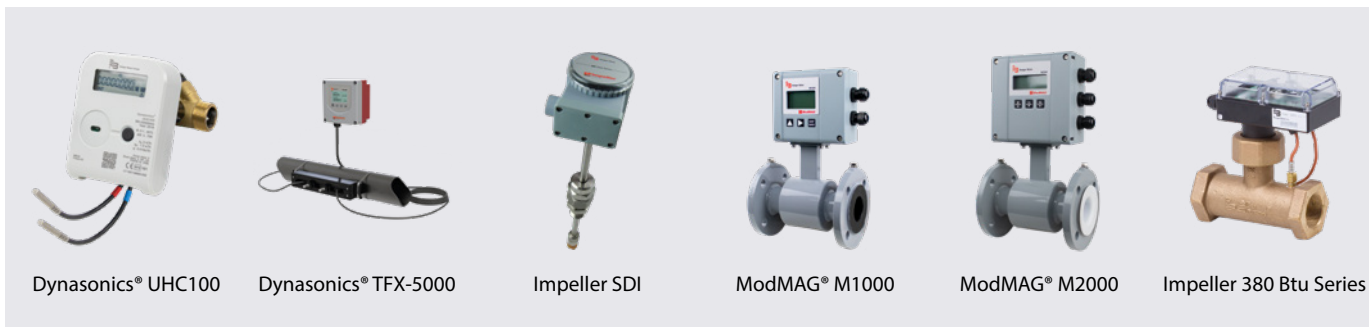

Solutions	Line Sizes	Application				Install Style			Communication				Certification			See Page		
		Heating	Cooling	Glycol water	Potable water	Inline	Insertion	Clamp-on	BACnet MS/TP	BACnet/IP	Modbus RTU	Mbus	AquaCUE®	EN1434 Class 2	CE		NSF 61 / 372	US/Canada Safety
Dynasonics® UHC100	1/2"...4" (DN15...DN100)	✓	✓		✓	✓						✓		✓	✓			23
Dynasonics® TFX-5000	1/2"...48" (DN15...DN1200)	✓	✓	✓	✓			✓	✓	✓	✓		✓		✓	NA	✓	24
Impeller SDI + FC5000	1 1/2"...36" (DN40...DN900)	✓	✓	✓	✓		✓		✓		✓	✓		✓				29
Impeller SDI + 212	1 1/2"...36" (DN40...DN900)	✓	✓	✓	✓		✓				✓	✓		✓	✓			29
ModMAG® M1000 + FC5000	1"...10" (DN25...DN250)		✓	✓	✓	✓			✓		✓	✓	✓		✓	✓	✓	28/29
ModMAG® M1000 + 212	1"...10" (DN25...DN250)		✓	✓	✓	✓					✓	✓	✓	✓	✓	✓		28/29
ModMAG® M2000 + FC5000	1"...10" (DN25...DN250)		✓	✓	✓	✓			✓		✓	✓	✓		✓	✓	✓	28/29
ModMAG® M2000 + 212	1"...10" (DN25...DN250)		✓	✓	✓	✓					✓	✓	✓	✓	✓	✓		28/29
Impeller 380 Btu Series	3/4"...2" (DN20...DN50)	✓	✓	✓	✓	✓			✓		✓							31

## Measurement Location

E

W

### Hydronic System

Hydronic systems can use chiller, boilers, or heat exchangers to accordingly increase or decrease the temperature of the water-based fluid in the hydronic system. Buildings may use external heat or cooling sources to further reduce energy costs. During chiller operation, banks of chillers are staged up and down to meet demand as chillers typically need to a load between 40% and 80% for proper operation.

Because flow rate and the amount of energy distributed varies by the season, especially for heat, be sure to select a measurement device that accommodates the design flow rate and the minimum flow rate.

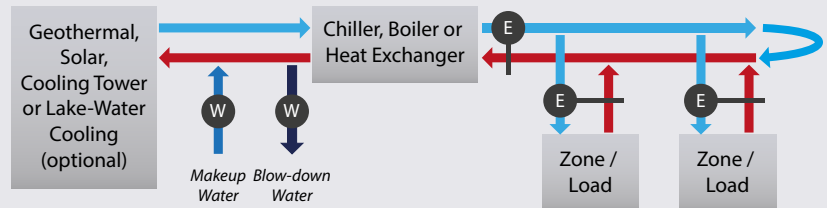

### Boiler Energy Management

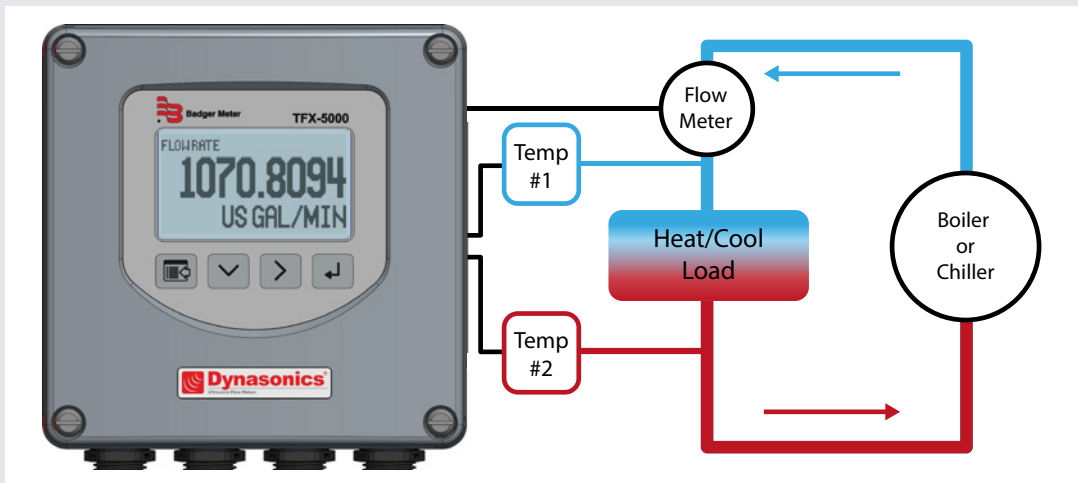

Energy flow meters at key locations provide measures of system efficiency and energy use. Energy flow meters calculate energy using one flow rate measurement and two temperature measurements.



## District Cooling and Heating

District cooling is the modern and efficient way to air condition clusters of buildings in cities and on campuses. In a district cooling system, a central plant with large and highly efficient industrial equipment that produces chilled water for supplied buildings through an isolated underground piping network. Cold supply water enters the buildings and flows to a heat exchanger, absorbing heat from the building space and providing air conditioning. The warmed water recirculates back to the central plant through a closed loop return line. The warmed water recirculates back to the central plant through a closed loop return line.

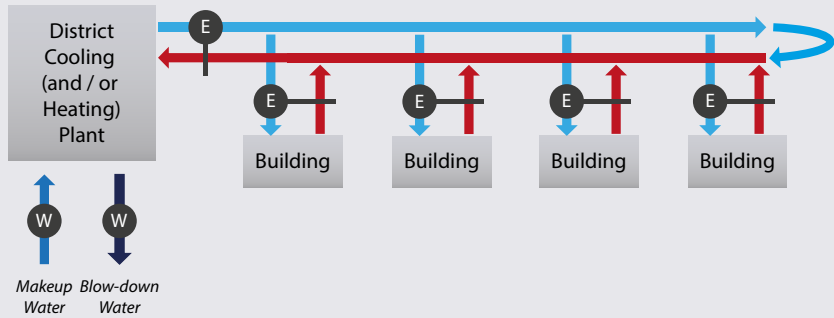

## Cooling Towers

Ideally, the amount of makeup water added to a cooling tower loop should equal the amount of water lost through evaporation and blow-down water. The amount of water lost through evaporation will vary based on the type and efficiency of the cooling tower and the amount of cooling. Using too much make-up water often signals a system leak or stuck valve.

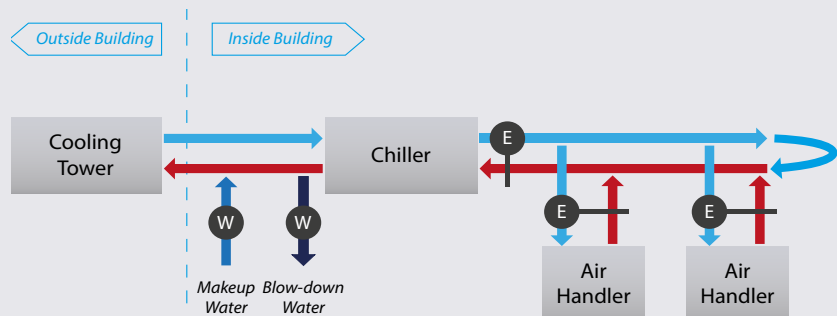

# Steam Heating

Steam-based systems are used to efficiently and cost-effectively heat facilities in cooler climates. Steam-based systems, similar to hydronic systems, are used in both district heating networks and in individual systems.

**IN STEAM HEAT SYSTEMS, MEASURE:**

1. Energy at each boiler or chiller to determine system efficiency.
2. Energy at each tenant, zone or apartment to determine cost allocation and distribution network load balancing.
3. Make-up water.
4. Wastewater from system blowdown.
5. Water condensate return. Condensate is a byproduct of steam as it cools and offsets make-up water.

## Flow Meter Overview



Product	Line Sizes	Install Style			Communication					Certification		See Page	
		Inline	Insertion	Clamp-on	BACnet MS/TP	BACnet/IP	Modbus RTU	Mbus	AquaCUE®	CE	US/Canada Safety		
Vortex VN2000	2" ...36" (DN50...DN900)		✓		✓		✓						35
Preso® Cone Meter	1/2" ...24" (DN15...DN600)	✓			Depends on selected pressure transmitter							36	

## Measurement Location



**Steam Load Management**

Measures energy efficiency by measuring steam delivery through a pipe to a heating zone. Low flow capability is important to understand system operation across all settings of heat generation.

The diagram illustrates a steam system. A central boiler is shown with two water (W) inputs: 'Makeup Water' (blue arrow pointing up) and 'Blow-down Water' (blue arrow pointing down). A main steam (S) pipe (blue arrow) exits the boiler to the right. This pipe branches into two parallel pipes, each leading to a 'Zone / Load' box. Each zone has a steam (S) input (blue arrow pointing down) and a return pipe (red arrow pointing up). A return pipe (blue arrow) also exits the right side of the system, looping back to the boiler. A water (W) input (blue arrow) is shown entering the system from the left.

# Water Measurement and Optimization

Water is vital for life and has become a scarce resource in many locations. From commercial facilities to residences to factories, people and the things that we consume and use require water. Besides climate change, economic growth and overpopulation are among the main causes of water scarcity. Another cause is increasing environmental pollution. If a water source is polluted by oil or by toxic substances in the air, it is no longer available as a drinking water reservoir.

As water scarcity increases, regional governments respond by establishing water usage restrictions or mandating water use reductions. The first step in managing or reducing water usage is to understand your water usage baseline. You cannot manage what you do not measure. Badger Meter provides a complete portfolio of solutions for measuring water usage from small to large pipe, with solutions for common applications including:

- Potable water
- Reclaimed water
- Landscape / irrigation water
- Wastewater

To understand water consumption within a facility that consumes water in multiple locations, Badger Meter recommend adding flow meters at key locations to provide zone-specific water usage reductions. Common areas measure water within a facility includes:

- Residents or tenants
- Food services
- Landscape / irrigation
- Pool / spa
- Cooling towers
- Departments, such as in manufacturing or medical facilities
- Other facility zones



# Effective Water Measurement for Smarter Buildings

Due to water scarcity, everyone is exploring and implementing methods to reduce total water consumption and waste. While builders designed and oversized the plumbing in older buildings to accommodate future occupancy, even new buildings with more optimized plumbing are finding that bathrooms, appliances, and people are continuing to reduce water usage on an ongoing basis.

## IMPORTANT POTABLE WATER FLOW METER SECTION TIPS:

1. Always select a flow meter sized to measure the anticipated flow rates based on expected water usage.
2. Strategically position flow meters in all key locations, such as by bathrooms and kitchens, to more quickly pinpoint abnormal water usage patterns that could indicate a possible leak.
3. Always be mindful of site installation constraints when selecting a meter because while all meters should be plumbed to operate under full pipe conditions, some meters require straight runs of pipe before and after the meter.

## Share the data where needed

W

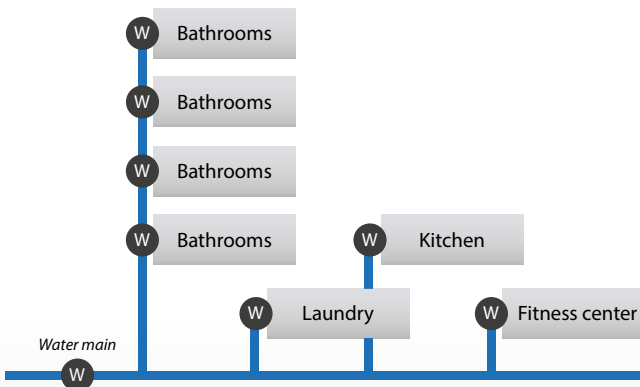

Because not all currently deployed building management systems provide data views to allow an entire organization to view and manage water usage, Badger Meter flow meters offer multiple output options to enable sharing of water measurement data.

1. Outputs for AquaCUE® and other water consumption dashboards
2. Modbus and BACnet connections for Building Energy Management Systems (BEMS)
3. Pulse and analog outputs
4. AquaCUE® provides an additional REST API interface for sharing water consumption data



# Flow Meter Overview



Product	Line Sizes	Application			Install Style			Communication					Certification			See Page
		Makeup Water	Blow-down Water	Condensate Return <sup>(2)</sup>	Inline	Insertion	Clamp-on	BACnet MS/TP	BACnet/IP	Modbus RTU	Mbus	AquaCUE®	CE	NSF 61 / 372	US/Canada Safety	
Dynasonics® TFX-5000	1/2"…48" (DN15…DN1000)	✓	✓	✓			✓	✓	✓	✓		✓	NA	✓	24	
ModMAG® M5000	1/2"…24" (DN15…DN600)	✓	✓	✓	✓					✓	✓	✓	✓		30	
ModMAG® M2000	1/4"…54" (DN6…DN1350)	✓	✓	✓	✓					✓	✓	✓	✓	✓	28	
ModMAG® M1000	1/4"…20" (DN6…DN500)	✓	✓	✓	✓					✓	✓	✓	✓	✓	28	
Impeller SDI	1 1/2"…36" (DN40…DN900)	✓	✓	✓		✓									27	
Dynasonics® U500w <sup>(1)</sup>	5/8"…4" (DN15…DN100)	✓	✓	✓	✓		✓					✓	✓	✓	25	
Recordall® Disc Meters	1/2" … 2" (DN15 … DN50)	✓	✓	✓	✓						✓	✓	✓	✓	33	

<sup>(1)</sup> Product available in the Americas only

<sup>(2)</sup> In use with a ModMAG® meter, the conductivity of the condensate return must be > 20 µS/cm.

# Optimization

## AquaCUE® turns your data into proactive intelligence

The AquaCUE® Flow Measurement Manager brings a new level of optimizing information to light. Its intuitive software suite with targeted advanced metering analytics, combined with proven cellular communication technologies, enables greater visibility and control over water resources. The system puts interval meter data to work to address demands for actionable intelligence and improve operations.

Cellular endpoints minimize the need for complicated infrastructure and pre-programmed to automatically broadcast hourly meter reading and event data to the system software. This information helps identify potential leaks and other anomalies in water use. The customizable dashboard delivers information set per individual requirements.

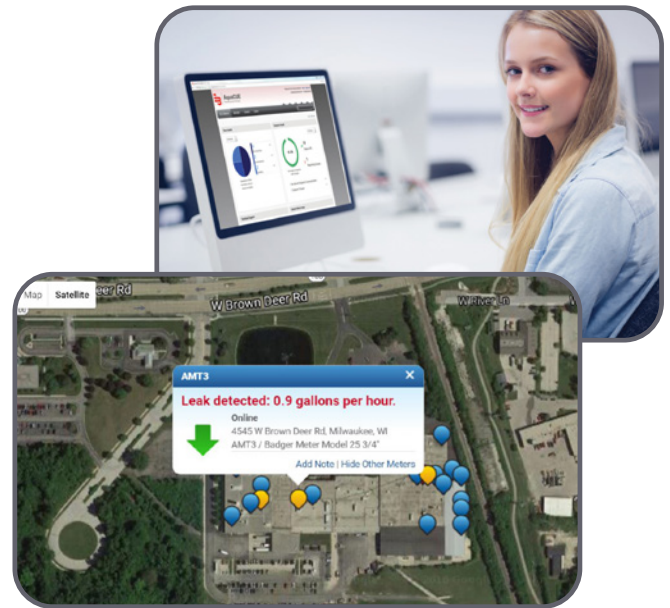

## Data transfer and data collection

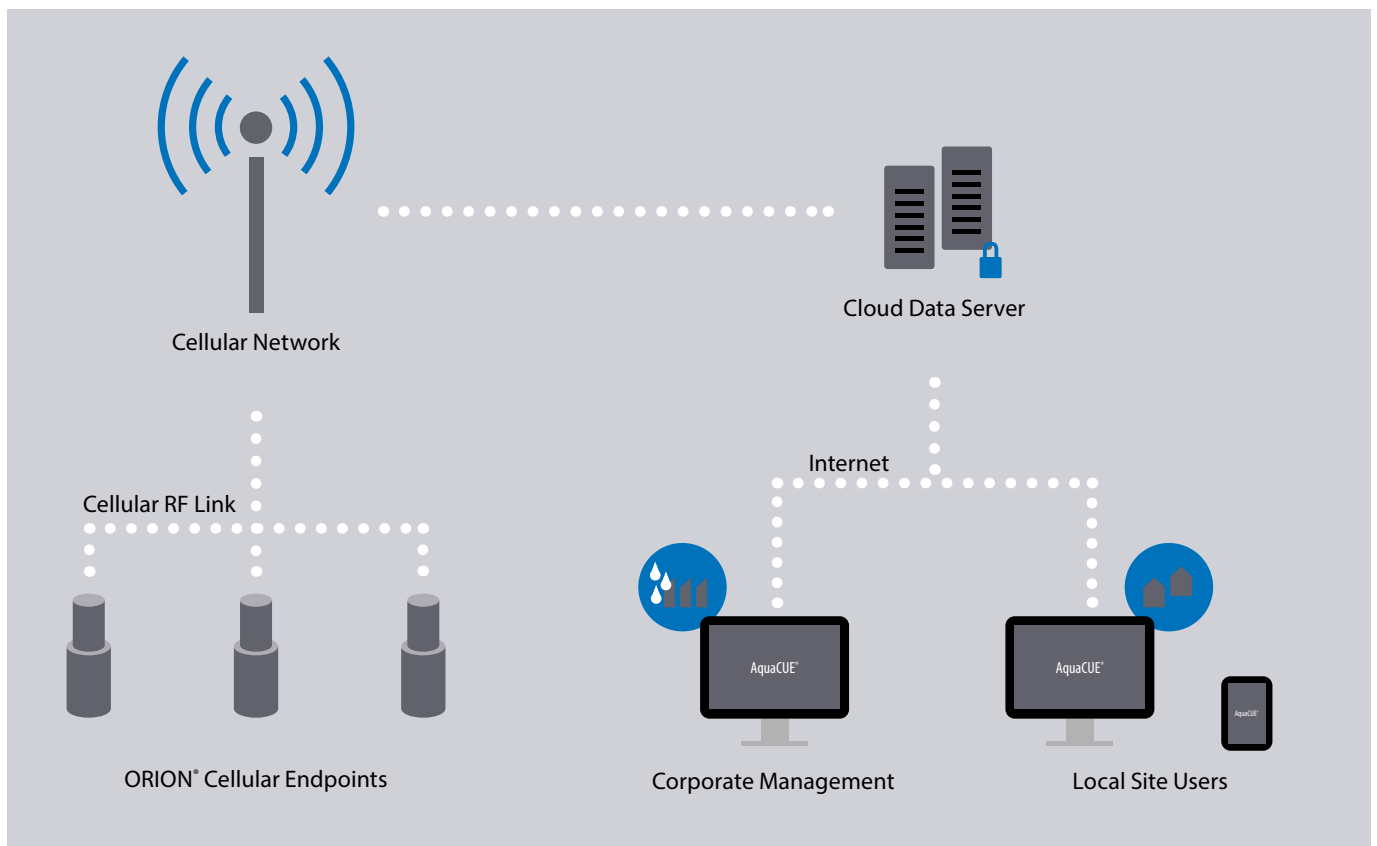

**Define and design**

Sub-metering improves water-use visibility. Identify, define and install flow meters anywhere water flows through a pipe. Set parameters and design the optimal flow management system to meet your water efficiency goals.

**Monitor and learn**

The intuitive AquaCUE® dashboard features in-depth analytics and graphs that incorporate historical data, such as temperature and rainfall overlays to provide an easy to understand picture of how water is currently being used throughout your facilities.

**Take action and make a difference**

With smart flow measurement comes smart flow management. AquaCUE® empowers users at all levels of an organization to identify and quickly address flow inefficiencies, equipment problems or wasteful behaviors. Smarter water consumption helps conserve water and save money.

**FEATURES YOU NEED**

- Customize dashboards to deliver information in a format matched to your response
- Ability to set unique alert conditions to define and monitor exceptions
- User friendly website interface enables access to users at all metering locations
- Secure, cloud-based - ISO 27001 certified and SOC 2 examined for security, availability and confidentiality
- Automatic software updates
- Integration with your operations and process systems via API

**Water Measurement**



Product	Line Sizes	Application			Install Style			Communication					Water Safety	See Page	
		Water	Wastewater	Landscape irrigation	Inline	Insertion	Clamp-on	BACnet MS/TP	BACnet/IP	Modbus RTU	Mbus	AquaCUE	Pulse and/or Analog		NSF 61 / 372
Dynasonics® TFX-500w	1/2"…10" (DN15…DN250)	✓		✓			✓		✓			✓	✓	NA	26
Dynasonics® TFX-5000	1/2"…48" (DN15…DN1000)	✓	✓				✓	✓	✓	✓		✓	✓	NA	24
Dynasonics® U500w <sup>(1)</sup>	5/8"…4" (DN15…DN100)	✓		✓	✓							✓	✓	✓	25
ModMAG® M5000	1/2"…24" (DN15…DN600)	✓	✓		✓					✓		✓	✓	✓	30
ModMAG® M2000	1/4"…54" (DN6…DN1350)	✓	✓		✓					✓		✓	✓	✓	28
Recordall® Disc Meters	1/2"…2" (DN15…DN50)	✓		✓	✓							✓	✓	✓	33
Recordall® Turbo Meters <sup>(1)</sup>	1 1/2"…12" (DN40…DN300)	✓			✓							✓	✓	✓	34

<sup>(1)</sup> Product available in the Americas only

# Irrigation

## Flow Meter Overview



Impeller SDI



Impeller 220 Series

Product	Line Sizes	Application			Install Style			Communication					Water Safety	See Page	
		Water	Wastewater	Landscape irrigation	Inline	Insertion	Clamp-on	BACnet MS/TP	BACnet/IP	Modbus RTU	Mbus	AquaCUE®			Pulse and/or Analog
Impeller SDI	1 1/2" ...36" (DN40...DN900)	✓				✓							✓		27
Impeller 220 Series	3" ...40" (DN80...DN1000)	✓		✓	✓	✓							✓		32

## Measurement Location



### Irrigation Water Management

A dedicated irrigation meter is a water meter that exclusively meters water used for outdoor watering and irrigation. A separate irrigation meter provides accurate measurement of outdoor water use and better ability to manage peak demands driven by irrigation demands.

Some water utilities and municipalities allow customers to deduct irrigation water usage from their wastewater billing. Irrigation systems are a common source of many leaks, the water lines are susceptible to freezing in some climates and raised sprinkler heads can be damaged during lawn mowing.

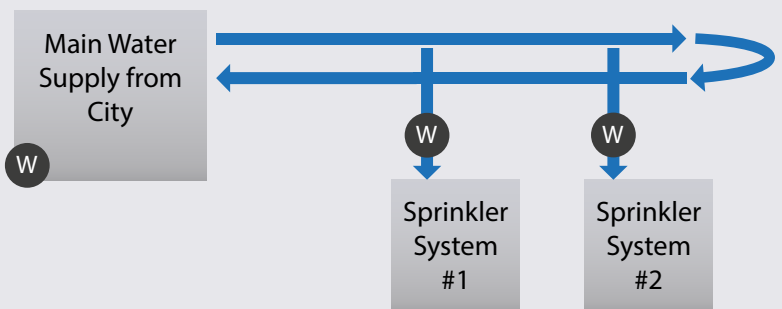



# Wastewater

## Flow Meter Overview



Dynasonics® TFX-5000



ModMAG® M1000



ModMAG® M2000

Product	Line Sizes	Application			Install Style			Communication					Water Safety	See Page	
		Water	Wastewater	Landscape irrigation	Inline	Insertion	Clamp-on	BACnet/MS/TP	BACnet/IP	Modbus RTU	Mbus	AquaCUE®			Pulse and/or Analog
Dynasonics® TFX-5000	1/2"…48" (DN15…DN1200)	✓	✓				✓	✓	✓	✓		✓	✓	NA	24
ModMAG® M1000	1/4"…8" (DN6…DN200)	✓	✓		✓					✓		✓	✓	✓	28
ModMAG® M2000	1/4"…54" (DN6…DN1350)	✓	✓		✓					✓		✓	✓	✓	28

## Measurement Location



### Wastewater Management

Humans consume vast quantities of water and create an increasing amount of wastewater. We help customers measure their water usage. Measurements help customers determine where they can reduce costs, identify losses and comply with water use restrictions.

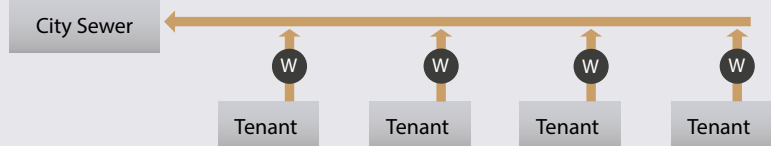

# Products

Ultrasonic flow meters, impeller meters, electromagnetic flow meters, nutating disc meters, vortex meters and differential pressure flow meters - all of these products are HVAC and water solutions.

**E****Hydronic Energy Measurement****W****Water Measurement****S****Steam Measurement**

# Dynasonics® UHC 100

E

## Ultrasonic Heat Meter / Cooling Energy Meter

The UHC 100 series has been designed to measure heating and cooling energy. It can be used with heating/cooling media (water or glycol solution) in centrally heated or cooled spaces such as residential houses or buildings.

### Features

- Static liquid metering using ultrasonic technology
- Heating and cooling
- EN1434:2015 Standard heat meter approval; Accuracy Class 2
- Canada Weights and Measures heat meter approval option, Accuracy Class 2
- No straight sections required for 1/2"...1-1/2" (DN15...50)
- Temperature of conveying liquid: 41...266° F (5...130° C)
- Fifteen year battery life or external power options
- Optional communication modules
- Mounting in any installation position
- Integral data logger with time/date



- Low flow ranges
- Small pipe sizes
- Cost-effective
- Horizontal/vertical installation

### Technical data

<b>Types</b>	<ul style="list-style-type: none"> <li>• Heat meter</li> <li>• Heating &amp; cooling energy meter</li> </ul>
<b>Sizes</b>	1/2"...2" (DN15...DN100)
	1/2"...1-1/2" NPT; 3/4...2" G thread (DN15...DN100)
<b>Flow rate</b>	2.19...219 gpm (0.6...60 m <sup>3</sup> /h)
<b>Display (flow rate/total)</b>	9-digit
<b>Protection class [IP]</b>	IP67
<b>Installation position</b>	All installation positions (vertical, horizontal)
<b>Nominal pressure</b>	Up to 232 psi (16 bar)
<b>Medium temperature measurement range</b>	41...266 °F (5...130 °C)
<b>Power supply</b>	<ul style="list-style-type: none"> <li>• External 24 VAC / VDC</li> <li>• 2 x 3.6 V battery</li> </ul>

# Dynasonics® TFX-5000



## Transit Time Ultrasonic Flow Meter

The TFX-5000 transit time ultrasonic flow meter measures volumetric flow and heating/cooling energy rates in clean liquids as well as those with small amounts of suspended solids or aeration, such as surface water or raw sewage.

By clamping on to the pipe, the meter installs without having to shutdown the system or drain the pipes and never contact the internal liquid.

### Features

- Large, bi-directional flow measuring range
- Data log up to 8 records
- Non-invasive clamp-on
- BACnet MS/TP, BACnet/IP, Modbus RTU, Modbus TCP and AquaCUE® connectivity
- Large, easy-to-read graphical display
- Rugged, aluminum enclosure for a long service life in harsh environments



- High flow ranges
- Large pipe sizes
- Cost-effective
- Horizontal/vertical installation

### Technical data

<b>Types</b>	<ul style="list-style-type: none"> <li>• Flow meter</li> <li>• Heating &amp; cooling energy flow meter</li> </ul>	
<b>Sizes</b>	1/2"...48" (DN15...DN1200)	
<b>Flow rate</b>	0.7...33000 gpm (0.19...7500 m <sup>3</sup> /h)	
<b>Accuracy</b>	Medium pipes	± 0.5% ± 0.0025 ft/s (0.008 m/s)
	Small pipes	1" (25 mm) and larger = ±1% ± 0.03 ft/s (0.009 m/s) 3/4" (20 mm) and smaller = ±1% of full scale
<b>Display (flow rate/total)</b>	8-digit	
<b>Installation position</b>	All installation positions (vertical, horizontal)	
<b>Medium temperature measurement range</b>	-40...350 °F (-40...176 °C)	
<b>Power supply</b>	<ul style="list-style-type: none"> <li>• External 24 VAC / VDC</li> <li>• Mains supply 85 - 264 VAC</li> </ul>	

# Dynasonics® U500w<sup>(1)</sup>

W

## Ultrasonic Water Meter

Dynasonics® U500w ultrasonic water meters use solid state technology in a compact, totally encapsulated, weatherproof and UV-resistant housing, suitable for building and property management submetering applications. Equipped with an easy-to-read, 9-digit LCD display, the ultrasonic meter presents consumptions, rate of flow, reverse-flow indication and alarms. With no moving parts, the U500w meter also improves reliability and has greater extended low flow accuracy compared to other positive displacement meters.

### Features

- Four sizes and lay lengths
- Completely submersible IP68
- Minimum extended low-flow rate lower than typical positive displacement meters.
- Simplified one-piece electronic meter and register that integral to the meter body.
- Sealed, non-removable, tamper-protected meter.
- Easy-to-read 9-digit LCD display.
- AquaCUE® connectivity



- Low flow ranges
- Small pipe sizes
- Cost-effective
- Horizontal/vertical installation

### Technical data

<b>Sizes</b>	5/8"...4" ( DN15...DN100)
<b>Flow rate</b>	0.1...1100 gpm (0.02...300 m <sup>3</sup> /h)
<b>Accuracy</b>	<ul style="list-style-type: none"> <li>• ±1.5% over the normal flow range</li> <li>• ±3.0% from the extended low flow range to the minimum flow value</li> </ul>
<b>Display (flow rate/total)</b>	9-digit
<b>Installation position</b>	All installation positions (vertical, horizontal)
<b>Nominal pressure</b>	Up to 175 psi (12 bar)
<b>Medium temperature measurement range</b>	45...140 °F (7...60 °C)
<b>Power supply</b>	Battery-powered
<b>Approvals</b>	NSF 61/372

<sup>(1)</sup> Product available in the Americas only



# Dynasonics® TFX-500w

W

## Ultrasonic Clamp-on Flow Meter

The TFX-500w ultrasonic clamp-on flow meter is quickly and easily installed without cutting or tapping the pipe. Ultrasonic waves transmit upstream and downstream through the pipe wall and water flowing in the pipes. By measuring the difference in the travel time and knowing the pipe size, the meter determines the velocity and flow rate. TFX-500w flow meters are a cost effective meter for measuring water flow in a variety of applications.

### Features

- Low installation costs
- Non-invasive clamp-on flow meter.
- Bidirectional, full pipe flow measurement.
- Measures flow rate, total and velocity of water flow.
- Large easy to read display.
- Set up through keypad interface and SoloCUE® software.
- Connects to AquaCUE® flow analytics.
- Modbus RTU and BACnet MS/TP communications.



- Low flow ranges
- Small pipe sizes
- Cost-effective
- Horizontal/vertical installation

### Technical data

<b>Sizes</b>	1/2"...10" (DN15...DN250)
<b>Flow rate</b>	0.1...9800 gpm (0.02...2673 m <sup>3</sup> /h)
<b>Accuracy</b>	±1
<b>Display (Flow rate/total)</b>	8-digit
<b>Installation position</b>	All installation positions (vertical, horizontal)
<b>Power supply</b>	Class II power supply is required; 9...28V DC@5 W maximum
<b>Temperature measurement range</b>	-40...250 °F (-40...121 °C)

# Impeller SDI

E

W

## Insertion Flow Sensor

The SDI series flow sensor offers unparalleled performance for liquid flow measurement in closed pipe systems in an easy-to-install economical package. Impeller sensors offer a quick response to changes in flow rate and are well suited to flow control and batch type applications in addition to flow monitoring. The new four-bladed impeller design is rugged, non-fouling and does not require custom calibration. The battery-powered versions are a complete flow measuring system providing a programmable display of rate, total or both powered by a "C" sized lithium battery.

### Features

- Low installation costs
- Single direction powered insert with raw, scaled pulse and analog output
- Bi-directional powered insert with analog and scaled pulse output
- Battery powered insert with a local and remote display and scaled pulse output



- High flow ranges
- Large pipe sizes
- Cost-effective
- Horizontal installation

### Technical data

<b>Sizes</b>	1-1/2"...36" (DN40...DN900)
<b>Accuracy</b>	±1%
<b>Installation position</b>	Horizontal installation
<b>Nominal pressure</b>	Up to 1000 psi (68 bar)
<b>Power supply</b>	<ul style="list-style-type: none"> <li>• Battery powerd</li> <li>• 8-35 VDC</li> <li>• 12-30 VAC</li> </ul>

# ModMAG® M1000 & M2000

E

W

## Electromagnetic Flow Meter

Combining a general-purpose detector with an amplifier, the ModMAG® M1000 and M2000 electromagnetic flow meters feature an advanced, user-friendly design and are for field verification testing with the use of a simple, handheld device. The meters are manufactured under strict quality standards and employ sophisticated, microprocessor-based signal conversion with accuracies up to 0.3 percent of reading for ModMAG® M1000 and 0.2 percent of reading for ModMAG® M2000. The wide selection of liner and electrode materials helps ensure maximum compatibility and minimum maintenance over a long operating period.

### Features

- Dual Hastelloy C electrodes come standard
- LCD display
- Verification device
- Bi-directional flow measurement sensing and totalization
- Digital and analog outputs
- Store and restore parameters
- AquaCUE® connectivity



- High flow ranges
- Large pipe sizes
- Cost-effective
- Horizontal/vertical installation

### Technical data

	<b>M1000</b>	<b>M2000</b>
<b>Sizes</b>	1/4"...20" (DN6...DN500)	1/4"...78" (DN6...DN2000)
<b>Flow velocity</b>	0.10...39.37 ft/s (0.03...12 m/s)	0.10...39.37 ft/s (0.03...12 m/s)
<b>Accuracy</b>	± 0.3 %	± 0.2 %
<b>Display</b>	LCD display	LCD display
<b>Installation position</b>	All installation positions (vertical, horizontal)	All installation positions (vertical, horizontal)
<b>Temperature measurement range</b>	Up to 302 °F (150 °C)	Up to 302 °F (150 °C)
<b>Power supply</b>	9...36 VDC, 92...275 VAC	10...36 VDC, 85...265 VAC

## **Impeller SDI and ModMAG® M1000/M2000 are compatible with FC-5000 BTU Monitor**

The FC-5000 product lines are microprocessor-driven devices designed for flow monitoring, while the BTU Monitor expands device capabilities by integrating inputs for fluid temperature data. Instantaneous rate and total energy consumption is achieved, simultaneously, while conforming to EN 1434 calculation standards.

### **Features**

- BTU calculator
- Large, easy-to-read display
- Intuitive navigation and programming
- Fully programmable inputs and outputs



- Scaled pulse output
- Communication via EIA-485 Modbus and USB
- Control panel mounted or wall mounted

## **Impeller SDI and ModMAG® M1000/M2000 are compatible with 212 Heat Calculator**

The 212 heat calculator has been designed to measure the energy consumed in hot water heating systems and chilled water cooling systems.

The 212 is supplied with temperature probes and easily interfaces with our impeller meters, electromagnetic flow meters and non-invasive ultrasonic flow meters.



- 4-20 mA output option
- Communication via M-Bus and Modbus RTU RS 485
- Control panel mounted or wall mounted
- Approved for EN1434

# ModMAG® M5000

W

## Battery-powered Electromagnetic Water Meter

The ModMAG® M5000 is a battery-powered electromagnetic flow meter with a very high accuracy even at very low flows. The excellent repeatability as well as the above-average battery life makes this innovative water meter indispensable for the water market. Typical applications are leak detection in water networks, water consumption measurements and irrigation plants.

The meter is best suited for applications without a power supply where exact consumption or flow rates are required. Of course, the ModMAG® M5000 can also be used with an available power supply. The meter can be powered with main voltage and in case of a main failure, it is powered by an internal battery. Important data are consequently saved.



- High flow ranges
- Large pipe sizes
- Cost-effective
- Horizontal/vertical installation

### Features

- LCD display
- Battery-powered
- Internal datalogger
- Strong battery life
- Excellent repeatability
- AquaCUE® connectivity

### Technical data

<b>Sizes</b>	1/2"...24" (DN15...DN600)
<b>Flow rate</b>	0.08...44816 gpm (0.018...10178 m <sup>3</sup> /h)
<b>Accuracy</b>	± 0.4 %
<b>Display</b>	LCD display
<b>Installation position</b>	All installation positions (vertical, horizontal)
<b>Temperature measurement range</b>	Up to 302 °F (150 °C)
<b>Power supply</b>	Battery-powered



# Impeller 380 Btu Series

E

## Flow Sensor with Btu Transmitter

The 380 BTU meter is an all-in-one energy usage package for monitoring hydronic heating and cooling systems. This meter accurately measures flow and temperature differential to compute energy and can interface with many existing control systems.

The rugged design incorporates an impeller flow sensor and two temperature probes. One temperature probe is conveniently mounted directly in the flow sensor tee. The second is placed on either the supply or the return line, depending on the application. These minimal connections help simplify installation and save time.

### Features

- Single direction powered insert BACnet or Modbus RS-485 communications protocols or a scaled pulse output
- Flow Rate, Flow Total, Energy Rate, Energy Total, Temp 1, Temp 2, and Delta T can all be transmitted on the RS-485 connection



- Low flow ranges
- Small pipe sizes
- Cost-effective
- Horizontal/vertical installation

### Technical data

<b>Sizes</b>	3/4"...2" (DN20...DN50)
<b>Flow rate</b>	1.7...157.3 gpm (0.36...35.7 m <sup>3</sup> /h)
<b>Accuracy</b>	± 2 %
<b>Installation position</b>	All installation positions (vertical, horizontal)
<b>Nominal pressure</b>	Up to 400 psi (27 bar)
<b>Temperature measurement range</b>	-4...260 °F (-20 °C...125 °C)
<b>Power supply</b>	12...35 VDC, 12...28 VAC

# Impeller 220 Series

W

## Flow Sensor

220 Series sensors are specifically designed for installation in underground vaults that might be subjected to flooding.

As the liquid flow turns the impeller, a low impedance 8V DC square wave signal is transmitted with a frequency proportional to the flow rate. This signal can travel up to 2,000 feet (610 m) between the sensor and the display unit without the need for amplification.

### Features

- Six-bladed impeller design with a proprietary, non-magnetic sensing mechanism
- Sensor electronics easily removed from tee
- Two-wire sensor - power and signal transmit on a single pair of wires up to the distance of 2000 feet (610 m)
- Flow indicators are configured with two 48 inch (DN1200) single conductor leads
- Digital signal easily interfaced with transmitters, monitors or PLCs



- Low flow ranges
- Small pipe sizes
- Cost-effective
- Horizontal/vertical installation

### Technical data

<b>Sizes</b>	1/2"...4" (DN15...DN100)
<b>Flow rate</b>	0.3...30 ft/sec (0.9...9.14 m/sec)
<b>Accuracy</b>	± 1 %
<b>Installation position</b>	All installation positions (vertical, horizontal)
<b>Nominal pressure</b>	Up to 400 psi (27 bar)
<b>Temperature measurement range</b>	Up to 221 °F (105 °C)

# Recordall® Disc Meters

W

## Nutating Disc Flow Meters

The Recordall® disc meter combines the accuracy of positive displacement design with the reliability and economy of nutating disc technology. They provide an accurate, cost-effective solution for your residential metering needs. Combining the accuracy of positive displacement meters with the reliability and economy of nutating disc technology, the simple but efficient design of this meter makes it an ideal solution for measuring flow. Well suited for measuring the flow of water and compliant with Safe Water Drinking Act.

### Features

- Delivers precision accuracy with extended flow ranges
- Light weight
- Magnetic coupling



- Low flow ranges
- Small pipe sizes
- Cost-effective
- Horizontal/vertical installation

### Technical data

<b>Sizes</b>	1/2"...2" (DN15...DN50)
<b>Flow rate</b>	0.5...170 gpm (0.3...38 m <sup>3</sup> /h)
<b>Accuracy</b>	± 1.5 %
<b>Installation position</b>	All installation positions (vertical, horizontal)
<b>Nominal pressure</b>	Up to 150 psi (10 bar)

# Recordall® Turbo Meters<sup>(1)</sup>

W

## Turbine Flow Meters

The Recordall® Turbo Meter is a rugged, reliable meter ideally suited for measuring potable water applications. Its compact size and ease of serviceability without removal from the line make this a cost effective selection. Designed with performance in mind, the meter provides a high level of accuracy over a wide flow range with a minimum of pressure loss.

### Features

- Direct coupled turbine based on an exclusive “floating rotor” design that reduces bearing friction and associated wear and tear
- Low pressure loss for improved system efficiency
- Exceptional registration accuracy across low flow rate, normal operating flow rate and maximum continuous operation flow
- Permanently sealed, tamper-resistant register or encoder
- AquaCUE® connectivity



- High flow ranges
- Large pipe sizes
- Cost-effective
- Horizontal installation

### Technical data

<b>Sizes</b>	1 1/2"...12"
<b>Flow rate</b>	1:30
<b>Accuracy</b>	± 0.5 % ... ± 1.5 %
<b>Installation position</b>	Horizontal position
<b>Nominal pressure</b>	Up to 150 psi (10 bar)
<b>Temperature measurement range</b>	Up to 120 °F

<sup>(1)</sup> Product available in the Americas only

# Vortex VN2000

S

## Vortex Meters

### VN2000 Hot tap Insertion Flow Meter

The VN2000 Hot Tap Insertion Vortex Flow Meter measures the volumetric or mass flow rate of steam, gases or liquids over a large flow range. The meter is a heavy duty design engineered to stand up to the most abusive environments inside and outside the pipe. A removable insertion/extraction tool aids in installation or removal in high pressure applications.

### VN2000 Compact Insertion Flow Meter

The VN2000 Compact Insertion Vortex Flow Meter measures the volumetric or mass flow rate of steam, gases or liquids over a large flow range. The meter is a heavy duty design engineered to stand up to the most abusive environments inside and outside the pipe. The meter includes a mounting assembly to simplify the installation and ensure proper installation depth and orientation for a specified pipe size. Additionally, the probe length is sized to match the pipe size to minimize the meter length.



- High flow ranges
- Large pipe sizes
- Cost-effective
- Horizontal installation

## Technical data

Types	VN2000 Hot tap Insertion Flow Meter	VN2000 Compact Insertion Flow Meter
Sizes	2"...36" (DN50...DN900)	2"...24" (DN50...DN600)
Flow rate	Steam: 26...2282271 kg/m <sup>3</sup> Gas/air: 0.5...187593 kg/m <sup>3</sup>	Steam: 26...981449 kg/m <sup>3</sup> Gas/air: 0.5...80671 kg/m <sup>3</sup> Liquids: 52...142280 kg/m <sup>3</sup>
Accuracy	± 1 %	± 1 %
Display	Rotatable display: Flow rate - 6 digits	Rotatable display: Flow rate - 6 digits
Installation position	Horizontal installation	Horizontal installation
Nominal pressure	Up to 1000 psi (68 bar)	Up to 1000 psi (68 bar)
Temperature measurement range	-250...400 °F (-120 °C...204 °C)	-250...400 °F (-120 °C...204 °C)
Power supply	14...36 VDC, (loop-powered with 4...20 mA) option, 28 VDC max	14...36 VDC, (loop-powered with 4...20 mA) option, 28 VDC max



# Preso<sup>®</sup> Cone Meter

S

## Cone Differential Pressure Flow Meter

The Preso<sup>®</sup> Cone differential pressure flow meter has a cone-shaped element that shapes the flow profile ahead of the differential pressure measurement port without impacting the flow against a sharp surface, creating an extremely stable signal for measurement with minimal wear on the cone edge.

### Features

- Little or no straight run piping requirements
- No additional flow conditioning devices needed
- Low maintenance and long life
- Wide variety of fluids
- No moving parts
- Low head loss

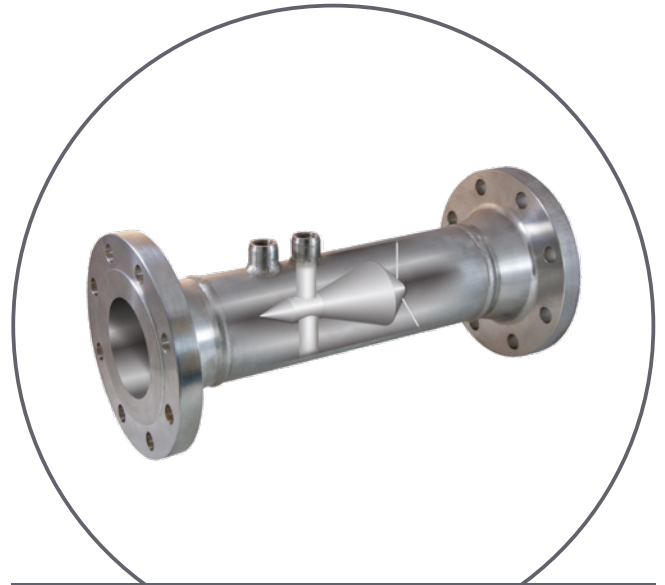

- High flow ranges
- Large pipe sizes
- Cost-effective
- Horizontal/vertical installation

### Technical data

<b>Sizes</b>	1/2"...24" (DN15...DN600)
<b>Flow rate</b>	10:1 and greater
<b>Accuracy</b>	± 0.5 %
<b>Installation position</b>	All installation positions (vertical, horizontal)









## **Control. Manage. Optimize.**

Trademarks appearing in this document are the property of their respective entities. Due to continuous research, product improvements and enhancements, Badger Meter reserves the right to change product or system specifications without notice, except to the extent an outstanding contractual obligation exists. © 2021 Badger Meter, Inc. All rights reserved.

**[www.badgermeter.com](http://www.badgermeter.com)**