



**VALVE ACCESSORIES & CONTROLS**  
200 Jade Park • Chelsea, AL 35043  
TEL: 205.678.0507  
[info@vacaccessories.com](mailto:info@vacaccessories.com)

# Electro-Pneumatic Positioner TZIDC-120 for FOUNDATION Fieldbus

## Operating Instructions

Document No.: 42/18-82 EN  
Issued: 04.05

### Manufacturer

**ABB Automation Products GmbH**

Schillerstr. 72

32425 Minden

Germany

Tel: +49 551 905-534

Fax: +49 551 905-555

CCC-support.deapr@de.abb.com

### Note

More information, e.g. regarding configuration, operation and ordering details, is available on CD.

© Copyright 2005 by ABB Automation Products GmbH  
Modifications reserved

This document is subject to copyright. It is intended to help the user operate the equipment safely and efficiently. The content may not be copied or reproduced either in part or in full without the prior consent of the copyright owner.

# Table of contents





<b>Important information</b> .....	5
<b>1 Safety summary</b> .....	6
<b>1.1 General safety instructions</b> .....	6
<b>1.2 Device-specific safety instructions</b> .....	7
1.2.1 General.....	7
1.2.2 Pneumatic safety.....	7
1.2.3 Electrical safety.....	8
<b>1.3 Explosion protection</b> .....	9
<b>1.4 Correct use</b> .....	9
<b>1.5 Qualified personnel</b> .....	9
<b>2 Manufacturer's information</b> .....	10
<b>2.1 Delivery</b> .....	10
<b>2.2 CE compliance information</b> .....	10
<b>3 Installing and commissioning</b> .....	11
<b>3.1 Mechanical mounting</b> .....	11
3.1.1 General.....	11
3.1.2 Operating conditions at the installation site.....	12
3.1.3 Mounting the positioner to linear actuators.....	12
3.1.4 Mounting the positioner to rotary actuators.....	17
<b>3.2 Pneumatic connection</b> .....	20
3.2.1 Safety instructions.....	20
3.2.2 Making the pneumatic connections.....	20
3.2.3 Mounting the splash guard cap.....	21

<b>3.3</b>	<b>Electrical connection</b> .....	22
3.3.1	Safety instructions .....	22
3.3.2	General installation instructions .....	22
3.3.3	Overview.....	23
<b>3.4</b>	<b>Setting jumpers on the motherboard</b> .....	25
<b>3.5</b>	<b>Commissioning</b> .....	26
3.5.1	Procedure .....	26
3.5.2	Requesting bus information .....	28
3.5.3	Local operation (bus device).....	29
3.5.4	Parameter setting example .....	30
<b>3.6</b>	<b>Functional test / maintenance</b> .....	31
3.6.1	Functional test of the shutdown module .....	32
<b>4</b>	<b>Technical data</b> .....	33
4.1	Fieldbus specifications .....	33
4.2	Basic model.....	34
4.3	Options .....	38
<b>5</b>	<b>Certificates</b> .....	40
<b>Appendix A: Configuration overview</b> .....		58

# Important information

## Symbols

In order that you can make the best use of this document and to ensure safety during commissioning, operation and maintenance of the equipment, please note the following explanation of the symbols used:

Symbol	Signal Word	Definitions
	<b>DANGER</b>	DANGER indicates an <b>imminently hazardous</b> situation which, if not avoided, <b>will result</b> in death or serious injury. (High level of risk.)
	<b>WARNING</b>	WARNING indicates a <b>potentially hazardous</b> situation which, if not avoided, <b>could result</b> in death or serious injury. (Medium level of risk.)
	<b>CAUTION</b>	CAUTION indicates a <b>potentially hazardous</b> situation which, if not avoided, <b>could result</b> in minor or moderate injury. (Low level of risk.)
	<b>NOTICE</b>	NOTICE indicates a <b>potentially harmful</b> situation which, if not avoided, <b>may result</b> in damage of the product itself or of adjacent objects. (Damage to property)
	<b>IMPORTANT</b>	IMPORTANT indicates useful hints or other special information which, if not observed, could lead to a decline in operating convenience or affect the functionality. (Does not indicate a dangerous or harmful situation.)

As well as the instructions in this document, you must also follow the generally applicable accident prevention and safety regulations.

If the information in this document is insufficient in any situation, please contact our service department, who will be happy to help you.

Please read this document carefully before installation and commissioning.

# 1 Safety summary

## 1.1 General safety instructions

This chapter provides important instructions for your safety. Thoroughly read and follow these instructions.

Proper and safe operation of the TZIDC-120 positioner requires:

- proper transportation and storage
- mounting, electrical and pneumatic installation and commissioning by qualified personnel (see chapter 1.5, page 9)
- correct operation according to the instructions in this manual
- correct use (see chapter 1.4, page 9)
- careful maintenance

The regulations, standards and directives referred to in this manual are applicable in Germany. When using the TZIDC-120 positioner outside the German jurisdiction, the relevant regulations, standards and directives applicable in the country where the device is used must be observed.

The TZIDC-120 positioner has been designed and tested in accordance with DIN VDE 0411 Part 1 / EN 61 010 Part 1

### **“Safety Requirements for Electronic Measuring Apparatus”**

(based on IEC Publication 348) and has been delivered in a safe condition.

In order to retain the device in a safe condition and ensure safe operation, attentively read and follow the instructions given in the sections marked with the respective symbols. (See “Important information” on page 5.) Otherwise, persons can be endangered or the device itself or other devices or equipment may be damaged or fail.

The device must be shut down and secured reliably against unintentional restart if it must be assumed that safe operation is no longer ensured. Possible reasons for this assumption can be:

- visible damage of the device
- failure of the electrical function
- exposure to a storage temperature of more than 85 °C for a longer time period
- exposure to considerable strain or wear during transport

Only the manufacturer is authorized to repair the device.

## 1.2 Device-specific safety instructions

### 1.2.1 General



**WARNING**

- Any user-made changes or manipulations of the device are prohibited! Only the manufacturer or an expert for explosion protection are authorized to modify the device.
- Before re-using a TZIDC-120 positioner that has already been used in another installation place **always** reset the device to the factory setting. Never start the autoadjustment function before having restored the factory setting! Otherwise, hazardous situations may occur due to improper settings.
- Do not use the internal communication interface (X5) on the motherboard when the TZIDC-120 positioner is installed and used in the hazardous area.
- The (optional) safety shutdown module must be subject to a functional test every two years at the latest. Follow the instructions in chapter 3.6.1.

### 1.2.2 Pneumatic safety



**WARNING**

- Observe the accident prevention rules of the Employers Liability Insurance Association.
- Observe the safety instructions for the pneumatic actuator used. The actuator's high actuating power may cause injuries!



**NOTICE**

- Take suitable precautions to ensure that even in case of malfunctions the positioner's max. admissible operating pressure of 6 bar (90 psi) is not exceeded. Otherwise, the positioner and/or the actuator may be damaged.
- The positioner must be supplied with instrument air exempt from oil, water and dust according to DIN/ISO 8573-1, Class 3
  - Purity: max. particle size 5  $\mu\text{m}$ , max. particle density 5  $\text{mg}/\text{m}^3$
  - Oil content: max. concentration 1  $\text{mg}/\text{m}^3$
  - Pressure dew point: maximum value 10 K below operating temp.

Before connecting the air pipes blow them out to remove dust, splinters and other particles.

## 1.2.3 Electrical safety



- Observe the common VDE safety regulations and the accident prevention rules of the Employers Liability Insurance Association.
- Observe the common standards and safety regulations for the installation and operation of electrical systems.
- When connecting the device, observe all electrical specifications in these operating instructions or in the data sheet.
- For the electrical installation of explosion-protected devices, observe all standards, regulations and directives governing explosion protection and applicable for the construction and use of explosion-protected systems, especially the DIN/VDE directives, the directives for explosion protection (VDE 0165 or EN 60079), and the special requirements and specifications for your devices (see the following chapter "Explosion protection" and chapter "Certificates" starting on page 40).
- Exclusively power devices with explosion protection via an electrically isolated circuit with safe extra-low voltage (SELV) in accordance with EN 60 950.



### Power supply

- The basic device is bus-powered via the Fieldbus connected to the bus terminals +(11) and -(12). The option modules have to be supplied separately.
- When connecting a power source for test purposes without establishing a bus communication (e.g. when executing the *Autoadjust* function), a supply voltage between 9.0 V DC and a maximum of 32 V DC can be applied.



### Electromagnetic interference

- Do not run bus/signal lines close to power lines. Power lines produce interference in their near vicinity which may affect the electrical capabilities of the bus/signal lines.
- In order to ensure electromagnetic compatibility (EMC), always use shielded cables conforming to the standards for the bus lines. When running the device with the option modules (proximity switches, microswitches, shutdown module) use shielded cables for these modules as well. All cable shields must be kept as short as possible and have to be connected to protective ground on both sides (use the grounding screw in the TZIDC-120 connection compartment on the device side).
- Keep the case closed. When the case is open, the positioning action may be affected through electromagnetic interference. This may result in a permanent positioning error, especially when the *Autoadjust* function is performed with the case open.



### 1.3 Explosion protection

One of the type plates seen below is attached to the positioner to the left of the main type plate, depending on the positioner's explosion protection. It indicates the degree of explosion protection and the certificate valid for your positioner. For details please refer to chapter "Certificates" starting on page 40.



**WARNING**

**Always** observe the specifications and special requirements for your positioner stipulated in the applicable certificate.

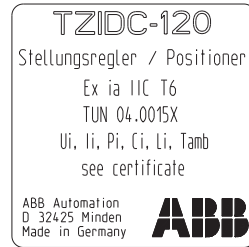

**Fig. 1** Type plate indicating the degree of explosion protection

### 1.4 Correct use

The TZIDC-120 positioner is an electro-pneumatic positioner for pneumatic final control elements. It is designed for being attached to linear and rotary actuators following the instructions in this manual. The positioner may be used only for the applications listed in these operating instructions or in the data sheet 18-0.24 EN. Any other use is considered as incorrect.

The signal current circuit and the input and output circuitry must meet the explosion protection requirements stipulated in the certificates (see chapter "Certificates" starting on page 40).

The maximum permissible ambient temperature range of -40 °C to +85 °C (when using proximity switches of type SJ2-S1N (NO): -25 °C to + 85 °C) must not be exceeded.

### 1.5 Qualified personnel

Only those persons familiar with the installation, commissioning, operation and maintenance of the TZIDC-120 positioner or similar instruments who have the required qualification and have read and understood the operating instructions are authorized to work on the TZIDC-120 positioner. These persons must be sufficiently trained and experienced and know the relevant standards and regulations to be able to judge their assigned tasks and recognize potential hazards. Only persons who are qualified or have been trained adequately and who have the required certificates are authorized to work on explosion-protected devices.

## 2 Manufacturer's information

### 2.1 Delivery

When receiving the delivery please immediately check items and scope for intactness and completeness. The scope of delivery is stated in the shipping documents. If ordered, the accessories (e.g. mounting material, pressure gauge block, filter regulator) are added to the delivery as individual items. Check items and scope of the delivery by means of the catalog numbers to see if types and quantities are in accordance with your order. If the positioner is delivered already mounted to the actuator, the positioner, accessories and actuator or final control element are considered as a common delivery item. A list of catalog numbers and details of the different versions and accessories can be found in data sheet 18-0.24 EN.

### 2.2 CE compliance information

We declare that we are the manufacturer of the TZIDC-120 positioner and that the product conforms with the EMC Directive 89/336/CEE as of May 1989 and meets the requirements of the following standards:

- EN 55022:1998 "Information technology equipment, Radio disturbance characteristics, Limits and methods of measurement"
- EN 61000-6-2:8/2002 "Electromagnetic compatibility (EMC)  
Part 6-2: Generic standards - Immunity for industrial environments
- EN 61000-6-3:3/2000 "Electromagnetic compatibility (EMC)  
Part 6-3: Generic standards - Emission standard for residential, commercial and light-industrial environments

The TZIDC-120 positioner complies with the EC directive for CE conformity certification.

### 3 Installing and commissioning

#### 3.1 Mechanical mounting

##### 3.1.1 General

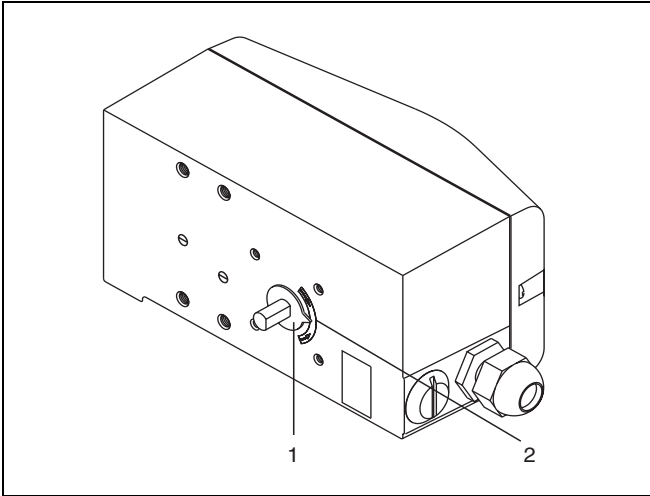

The arrow (1) on the feedback shaft (and thus the lever) must travel within the area marked with the small arrows (2).

**Fig. 2** Operating range

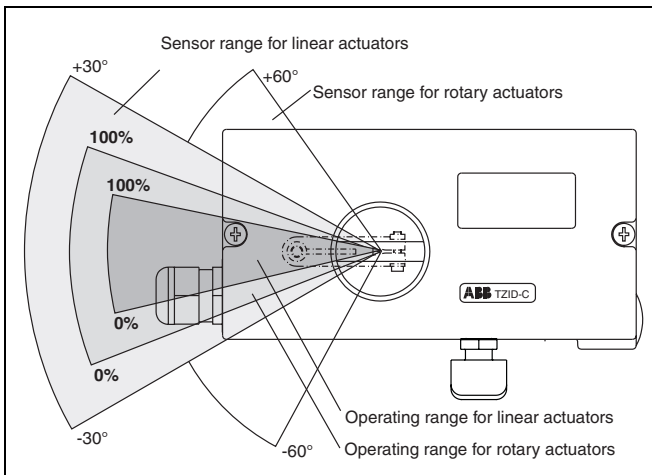

When mounting the positioner, ensure that the transfer of the stroke or rotation angle for the position feedback is correct. The maximum rotation angle is 60° for mounting to linear actuators and 120° for mounting to rotary actuators. The minimum angle is always 25°.

**Fig. 3** Positioner ranges

### 3.1.2 Operating conditions at the installation site



#### WARNING

Before installing check to ensure that the specifications in terms of safety and control applicable to the TZIDC-120 positioner will not be exceeded at the installation site of the actuator or final control element.

Ambient temperature:	-40 °C ... +85 °C (-25 °C ... + 85 °C when using proximity switches of type SJ2-S1N (NO))
Relative humidity:	95 % (mean annual value), condensation permissible. Observe the specifications for protection class IP65 / NEMA 4X and the technical data in this manual.
Explosion protection:	Observe the technical data, and the specifications in the certificates (see the relevant sections of this manual).
Mounting orientation:	any orientation allowed

### 3.1.3 Mounting the positioner to linear actuators

A special attachment kit is available for mounting the positioner to a linear actuator according to DIN/IEC 534 (lateral mounting to NAMUR) comprising the following parts:

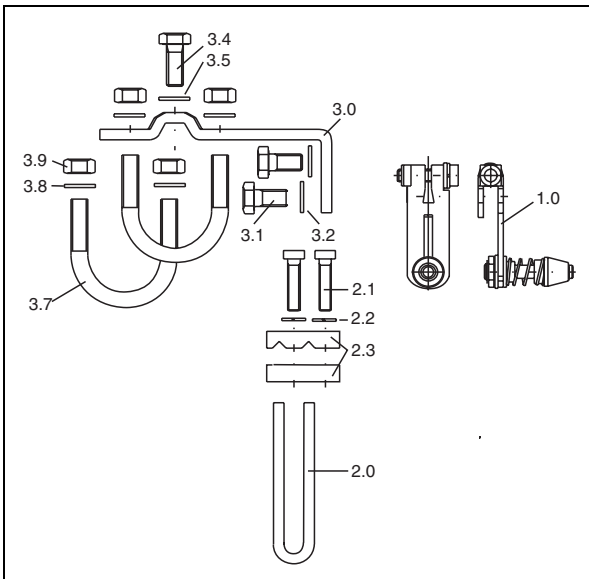

- Lever (1.0) with follower pin, for 10 ... 35 mm or for 20 ... 100 mm actuator travel
- Follower guide (2.0) with two screws (2.1), spring washers (2.2), and clamp plates (2.3)
- Angle bracket (3.0) with two screws (3.1), and two plain washers (3.2)
- Screw (3.4) and plain washer (3.5) for mounting to cast iron yoke
- Two U-bolts (3.7), each with two plain washers (3.8), and two nuts (3.9) for mounting to columnar yoke

**Fig. 4** Mounting kit for linear actuators

Tools required:	Wrench 10 mm /13 mm Allen key 4 mm
-----------------	---------------------------------------

Follow the procedure (steps 1 - 5) below to attach the positioner to a linear actuator:

### 1. Mount the follower guide to the actuator

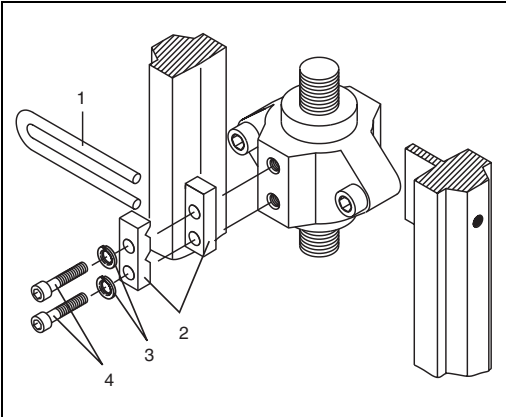

- Fasten the follower guide (1) and the clamp plates (2) with screws (4) and spring washers (3) to the spindle of the actuator; hand-tighten the screws.

**Fig. 5** Mounting follower guide to actuator

### 2. Assemble the lever (if not yet pre-assembled)

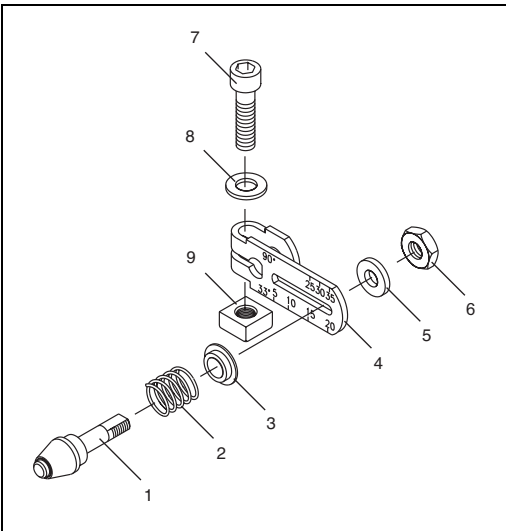

- Slip the spring (2) onto the bolt with the follower pin (1).
- Slip the plastic washer (3) onto the bolt and compress the spring with it.
- Insert the bolt with compressed spring into the oblong hole in the lever (4) and fasten it in the desired position using the plain washer (5) and nut (6) at the lever; the scale on the lever indicates the link point for the stroke range.
- Slip the plain washer (8) onto the screw (7), insert the screw into the lever and counter with the nut (9).

**Fig. 6** Assembling the lever

### 3. Mount the lever and the angle bracket to the positioner

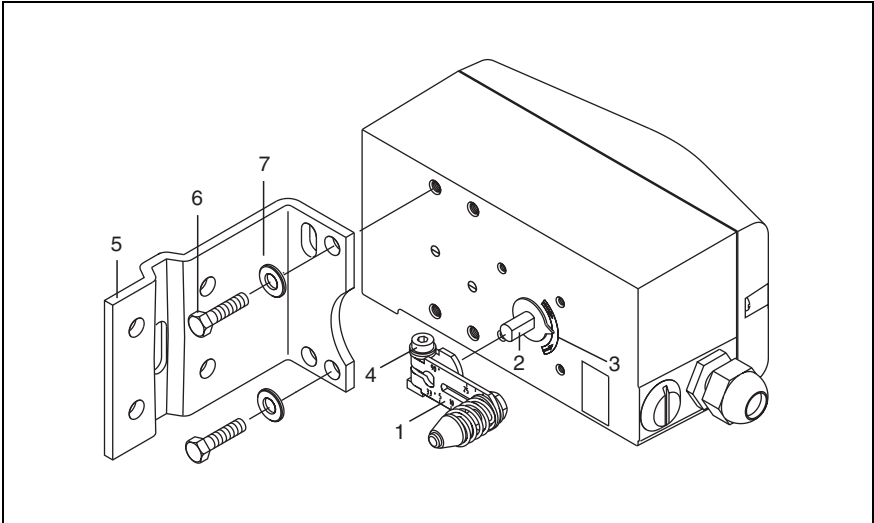

**Fig. 7 Mounting lever and angle bracket to the positioner**

- Attach the lever (1) to the positioner's feedback shaft (2) (can only be mounted in one position due to the flat on the side of the feedback shaft).
- Check whether the lever travels within the operating range (between the arrows) by observing the arrow marks (3).
- Hand-tighten the screw (4) at the lever.
- Hold the preassembled positioner with the angle bracket (5) still loose in such a way against the actuator that the follower pin on the lever introduces into the follower guide, in order to determine the bore holes of the positioner to be used for the angle bracket.
- Fasten the angle bracket (5) with screws (6), and plain washers (7) to the corresponding bore holes in the positioner case; if possible, tighten the screws evenly to ensure linearity during operation. Align the angle bracket in the oblong hole to achieve a symmetrical operating range (between the arrow marks (3)).

#### 4.a Mount the positioner to a cast iron yoke

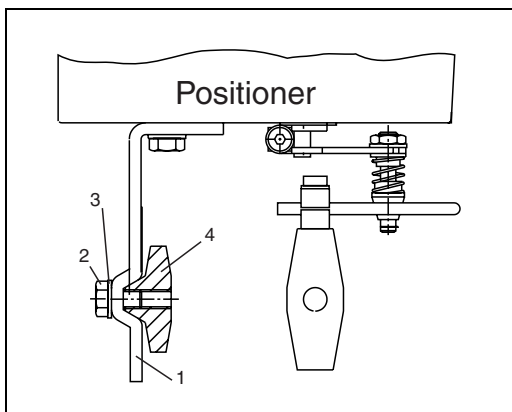

- Fasten the angle bracket (1) with screw (2), plain washer (3) to the cast iron yoke (4).

**Fig. 8** Mounting to cast iron yoke

or

#### 4.b Mount the positioner to a columnar yoke

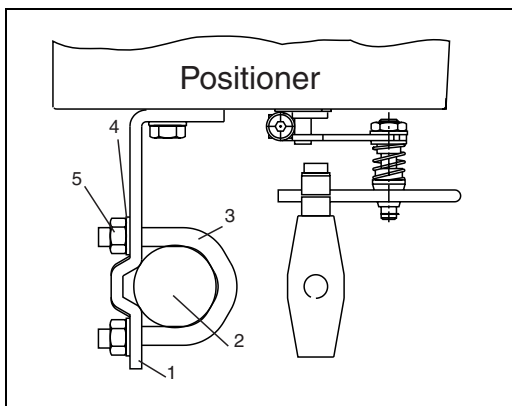

- Hold the angle bracket (1) in the appropriate position against the columnar yoke (2).
- Insert the U-bolts (3) from the inner side of the columnar yoke through the holes in the angle bracket.
- Slip on the plain washers (4), and nuts (5). Hand-tighten the nuts evenly.

**Fig. 9** Mounting to columnar yoke

**i**

Adjust the height of the positioner at the cast iron yoke or the columnar yoke until the lever is horizontal (at visual check) at half valve stroke.

**IMPORTANT**

Check the unit for proper mounting after having made the pneumatic and electrical connection (see chapter "Commissioning" on page 26).

## 5. Adjust the stroke

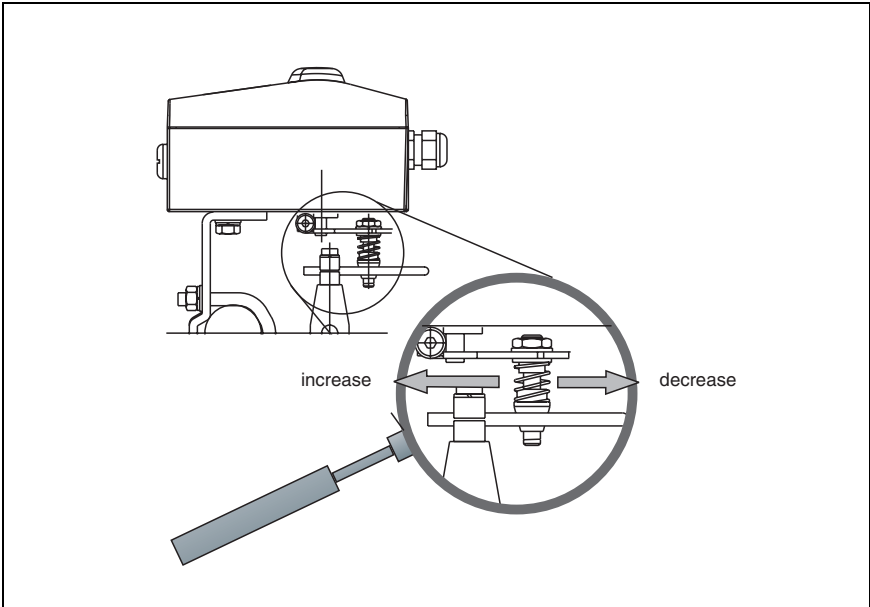

**Fig. 10 Positioner linkage**

The scale on the lever indicates the relevant points for the various valve stroke ranges.

You can adapt the valve stroke range to the operating range of the position sensor by shifting the bolt with follower pin in the oblong bore hole of the lever. When the link point is shifted to the inside, the position sensor's rotation angle is increased; shifting to the outside decreases the angle.

Set the stroke range in such a way that the used rotation angle of the position sensor is as great and as symmetrical around the center position as possible.

**Recommended range for linear actuators: between  $-28^\circ$  and  $+28^\circ$**

**Minimum angle:  $25^\circ$**



After mounting, check whether the positioner operates within the sensor range.

**IMPORTANT** Check the unit for proper mounting after having made the pneumatic and electrical connection (see chapter "Commissioning" on page 26).



### 3.1.4 Mounting the positioner to rotary actuators

The following mounting kit is available for mounting to a rotary actuator according to VDI/VDE 3845:

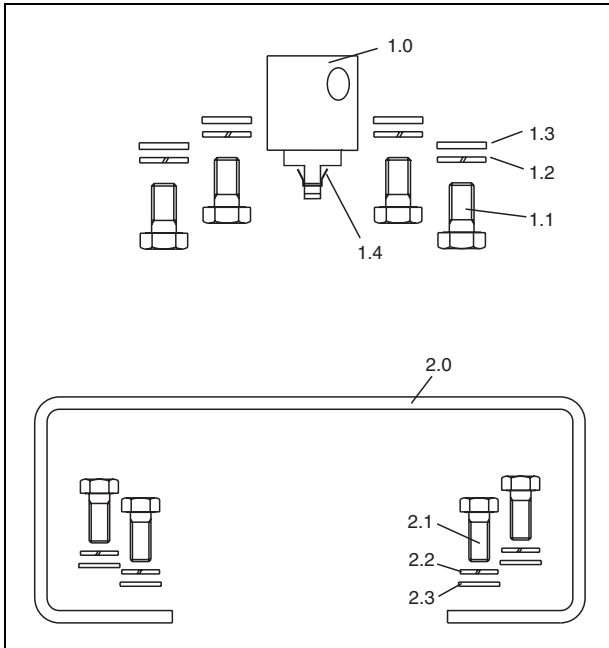

- Adapter (1.0) with spring (1.4)
- Four screws, M6 (1.1), four spring washers (1.2), and four plain washers (1.3) for fastening the bracket (2.0) to the positioner
- Mounting bracket (2.0)
- Four screws, M5 (2.1), four spring washers (2.2), and four plain washers (2.3) for fastening the bracket to the actuator

**Fig. 11 Mounting kit for rotary actuators**

Tools required:

Wrench 10 mm /13 mm  
Allen key 3 mm

Follow the procedure (steps 1 - 3) below to attach the positioner to a rotary actuator:

### 1. Mount the adapter to the positioner

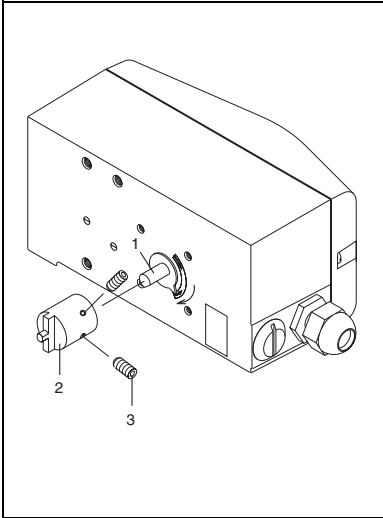

**Fig. 12** Mounting the adapter

- Determine the mounting position (in parallel to the actuator or shifted by 90°).
- Determine the direction of rotation of the actuator (clockwise or counterclockwise).
- Move the rotary actuator to its home position.
- On the basis of the mounting position, the home position, and the direction of rotation it must be determined in which position the feedback shaft (1) of the positioner must be pre-adjusted and in which position the adapter (2) must be placed, to enable the positioner to travel within the correct range (the arrow on the rear of the device must travel within the admissible range, for details see Fig. 2 on page 11).
- Pre-adjust the feedback shaft.
- Place the adapter on the feedback shaft in the appropriate position and fix it by set-screws (3); ensure that one of the set-screws is engaged on the side of the feedback shaft with the flat.

### 2. Attach the mounting bracket (1) to the positioner

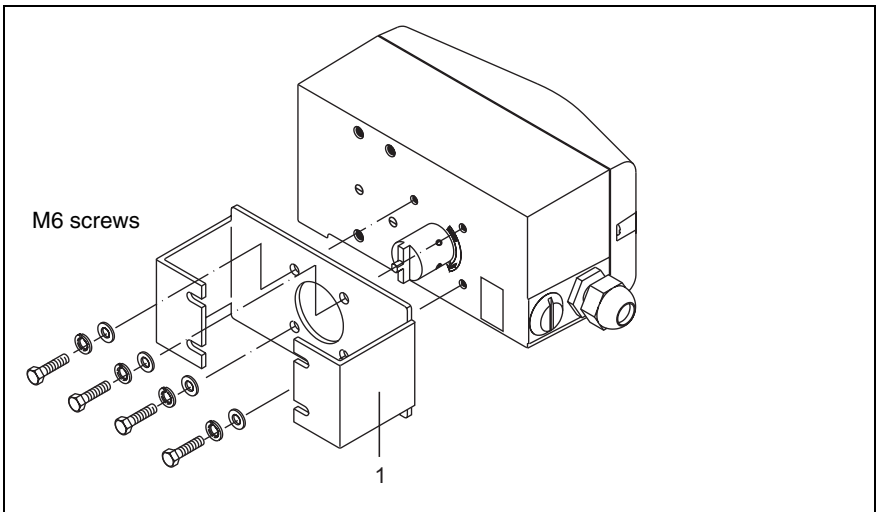

**Fig. 13** Attaching the mounting bracket to the positioner

### 3. Attach the positioner to the actuator

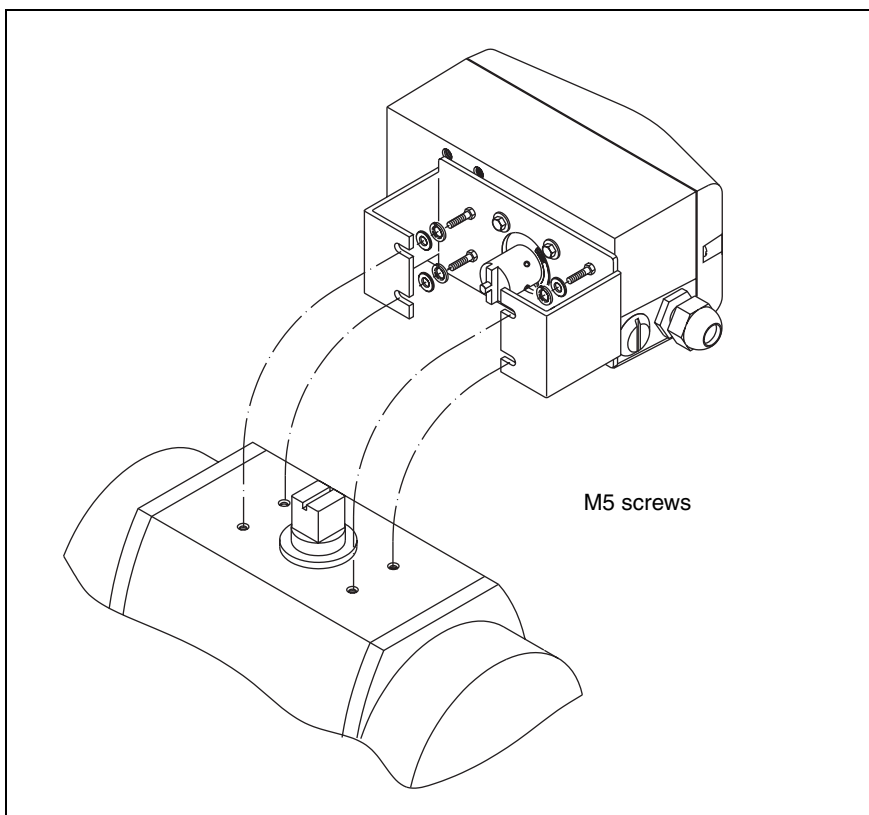

**Fig. 14 Attaching the positioner to the actuator**



After mounting, check whether the actuator's operating range is in accordance with the positioner's sensor range.

**IMPORTANT** Check the unit for proper mounting after having made the pneumatic and electrical connection (see chapter "Commissioning" on page 26).

## 3.2 Pneumatic connection

### 3.2.1 Safety instructions



- Observe the accident prevention rules of the Employers Liability Insurance Association.
- Observe the safety instructions for the pneumatic actuator used. The actuator's high actuating power may cause injuries!



- Take suitable precautions to ensure that even in case of malfunctions the positioner's max. admissible operating pressure of 6 bar (90 psi) is not exceeded. Otherwise, the positioner and/or the actuator may be damaged.
- The positioner must be supplied with instrument air exempt from oil, water and dust according to DIN/ISO 8573-1, Class 3
  - Purity: max. particle size 5  $\mu\text{m}$ , max. particle density 5  $\text{mg}/\text{m}^3$
  - Oil content: max. concentration 1  $\text{mg}/\text{m}^3$
  - Pressure dew point: maximum value 10 K below operating temp.

Before connecting the air pipes blow them out to remove dust, splinters and other particles.

### 3.2.2 Making the pneumatic connections

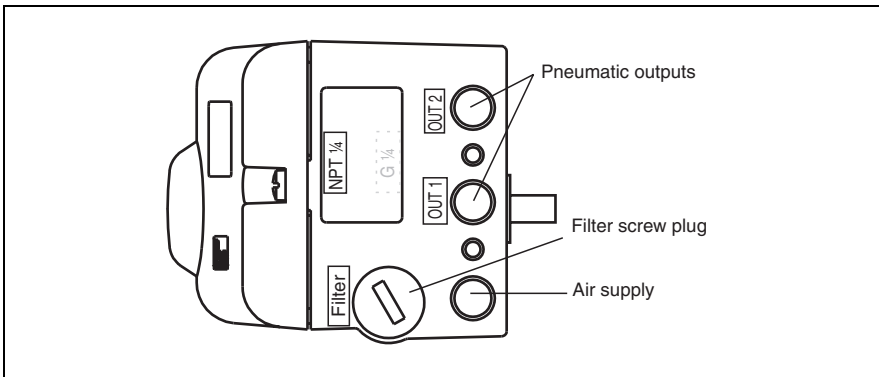

**Fig. 15 Pneumatic connections**

All pneumatic piping connections are located on the right-hand side of the positioner. Threaded bores G 1/4 or 1/4-18 NPT, respectively, are provided. The positioner is labeled according to the type of thread. The corresponding screwed pipe connections have to be supplied by the customer. We recommend pipes with the dimension 6 x 1 mm for the pneumatic piping.

The amount of supply pressure has to be matched to the working pressure necessary for the actuation. The positioner's operating range is between 1.4 and 6 bar.

The connections have to be arranged, according to their marks, in the following way:

Mark	Connection piping
-	Air supply, pressure 1.4...6 bar (20...90 psi)
OUT1	Output pressure, to actuator
OUT2	Output pressure, to actuator (for double-acting actuators)

### 3.2.3 Mounting the splash guard cap



#### NOTICE

Protection class IP 65 / NEMA 4 X is achieved only when the splash guard cap is in place. Do not use the positioner without the cap.

Screw the splash guard cap delivered with your positioner into the appropriate hole in the bottom plate of the case, as seen in the illustration below. Do not use a screw driver for this purpose!

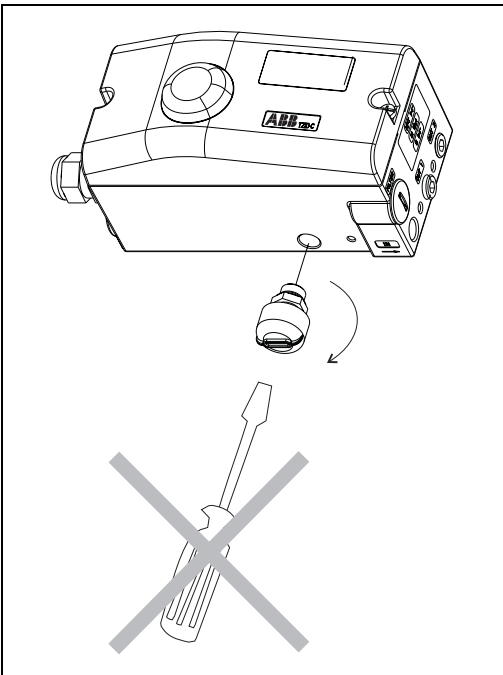

**Fig. 16** Mounting the splash guard cap

## 3.3 Electrical connection

### 3.3.1 Safety instructions



#### WARNING

- Observe the common VDE safety regulations and the accident prevention rules of the Employers Liability Insurance Association
- Observe the common standards and safety regulations for the installation and operation of electrical systems.
- When connecting the device, observe all electrical specifications in these operating instructions or in the data sheet.
- For the electrical installation of explosion-protected devices, observe all standards, regulations and directives governing explosion protection and applicable for the construction and use of explosion-protected systems, especially the DIN/VDE directives, the directives for explosion protection (VDE 0165 or EN 60079), and the special requirements and specifications for your devices (see chapter "Certificates" starting on page 40).
- Exclusively power devices with explosion protection via an electrically isolated circuit with safe extra-low voltage (SELV) in accordance with EN 60 950.

### 3.3.2 General installation instructions



#### NOTICE

Observe the following instructions. They are essential for proper operation and functionality of the positioner.

#### General

- Do not expose the terminals to strain.

#### Technical data

- When connecting the device, make sure that the electrical specifications in chapter 4 "Technical data" are observed.

#### Power supply

- The basic device is bus-powered via the Fieldbus connected to the bus terminals +(11)/-(12). The option modules must be supplied separately.
- When connecting a power source for test purposes without establishing a bus communication (e.g. when executing the *Autoadjust* function), a supply voltage between 9.0 V DC and a maximum of 32 V DC can be applied.



## Electromagnetic interference

- Do not run bus/signal lines close to power lines. Power lines produce interference in their near vicinity which may affect the electrical capabilities of the bus/signal lines.
- Always use shielded cables conforming to the standards for the bus lines, to ensure electromagnetic compatibility (EMC). When running the device with the option modules (proximity switches, microswitches, shutdown module) use shielded cables for these modules as well. All cable shields must be kept as short as possible and have to be connected to protective ground on both sides (use the grounding screw in the TZIDC-120 connection compartment on the device side).
- Keep the case closed. Otherwise, the positioning action may be affected through EMI, resulting in a permanent positioning error, especially when the *Autoadjust* function is performed with the case open.

### 3.3.3 Overview

Two threaded bore holes 1/2 - 14 NPT or M20 x 1.5 are available on the left hand side as the cable entry into the case. One is equipped with a cable gland and in the other a pipe plug is mounted.

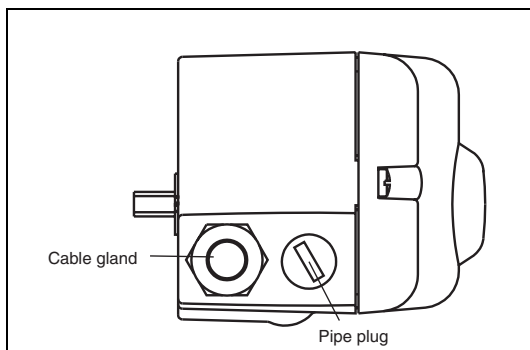

Fig. 17 Cable entry

The screw terminals inside the case are assigned as follows:

- 1 Not used
- 2 Service switch for the shutdown module
- 3 Terminals for the shutdown module
- 4 Kit for digital position feedback, either proximity switches or 24 V microswitches
- 5 Same as 4
- 6 Bus terminals
- 7 Grounding screw

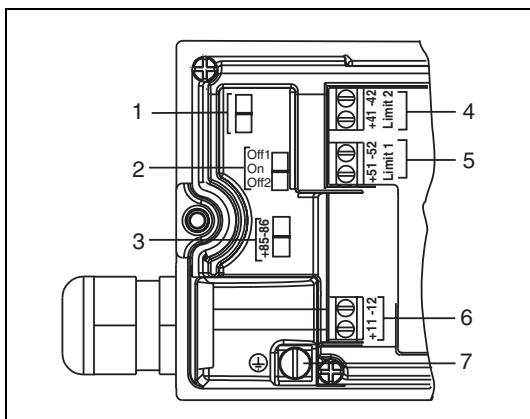

Fig. 18 Screw terminals

## 2. Connect the wires to the terminals

- Remove approximately 6 mm of the insulation.
- When connecting the bus lines, shutdown module, proximity switches or microswitches, insert the wire ends from the left into the appropriate screw terminal and hand-tighten the screws (access from above).

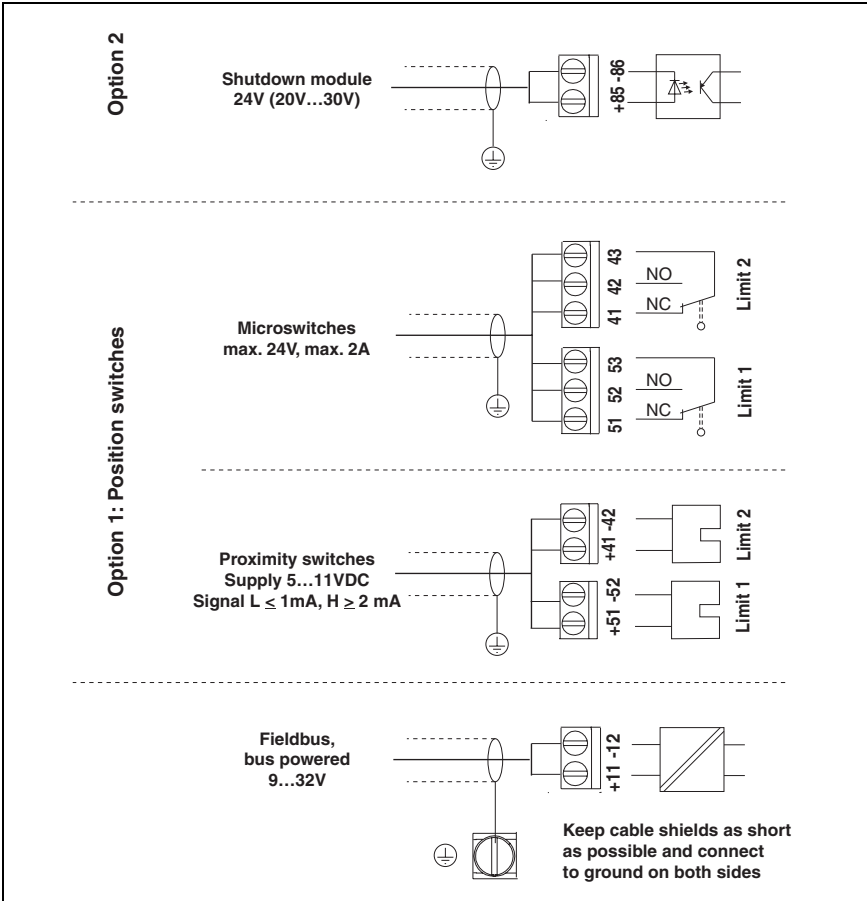
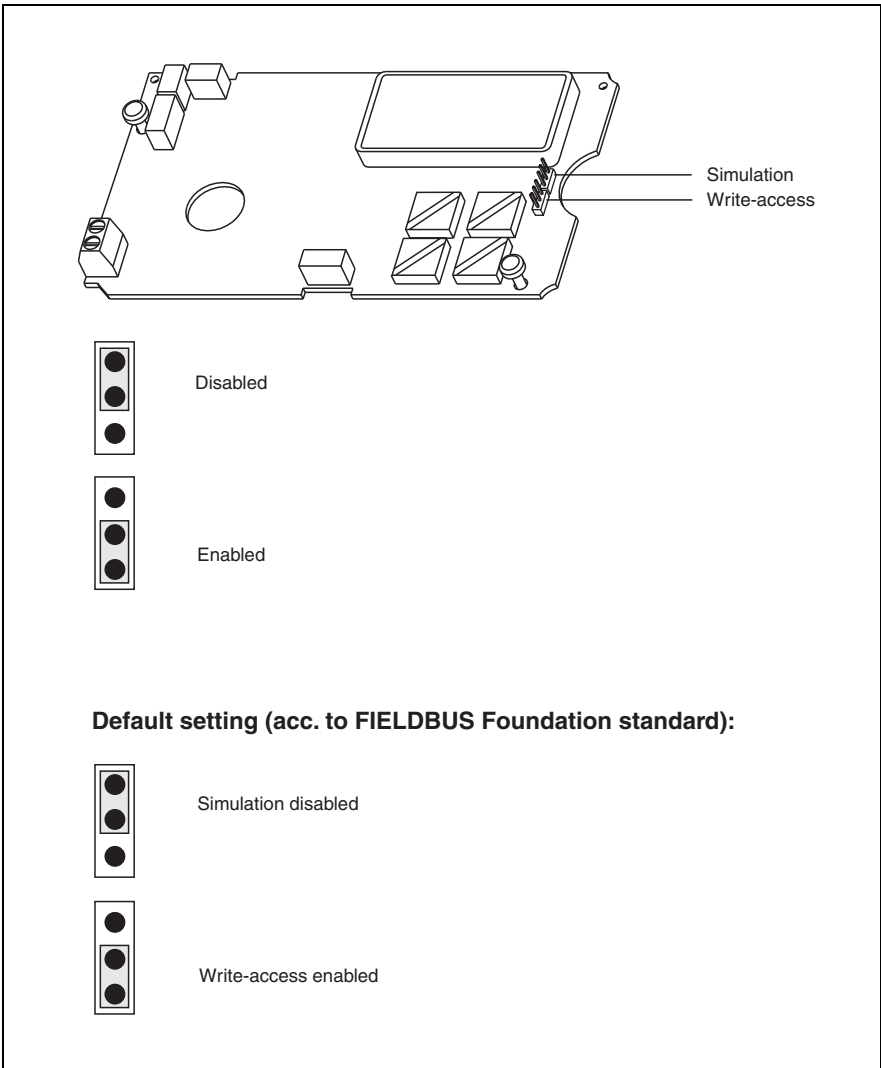

Fig. 19 Wiring diagram



### 3.4 Setting jumpers on the motherboard

Two jumpers can be set on the motherboard to enable/disable simulation or write access. Set the jumpers according to your needs as seen in the illustration below:



**Fig. 20 Jumper setting**

## 3.5 Commissioning

### **i** **Important**

The prerequisite for proper operation of the TZIDC-120 positioner on the bus is that the Transducer Block can change over to AUTO mode. This requires that the operating range of both the positioner and the valve be matched to each other (as described in step 5 of the procedure below). If this auto-adjustment should fail or cannot be performed for any reason, the Transducer Block remains in "Out of Service" mode and the configuration bit in the "BLOCK-ERR Parameter" is "active".

### 3.5.1 Procedure

1. Turn on the air supply to the positioner.
2. Connect the bus with arbitrary polarity (or auxiliary power 9 V DC ... 32 V DC) to the bus terminals.



is displayed.

3. Check for proper mounting:
  - Press and hold **MODE** and **ENTER** simultaneously. Wait until the countdown has run down from 3 to 0, then release **MODE** and **ENTER**. The operating level (mode 1.x) is reached and indicated.
  - Press and hold **MODE**.
  - Additionally briefly press **↑** or **↓** until mode **1.3** (manual adjustment within the sensor range) is displayed.
  - Release **MODE**.
  - Press **↑** or **↓** to move the actuator to its mechanical limit stops in both directions, and note the values. The angle of rotation is indicated in degrees.

#### **Recommended range:**

between  $-28^{\circ}$  and  $+28^{\circ}$  for linear actuators

between  $-57^{\circ}$  and  $+57^{\circ}$  for rotary actuators

**Minimum angle:  $25^{\circ}$**

### **i** **IMPORTANT**

The positioner should be mounted/adjusted in such a way that the portions of the sensor's operating range above and below the center point are nearly identical. Make sure to use the rotation angle of the position sensor in the positioner to its utmost extent. Refer to chapter 3.1 "Mechanical mounting" for details about how to readjust/correct if required.

4. Return to the remote level.
  - Press and hold **MODE** and **ENTER**.
  - Wait until the countdown has run down from 3 to 0, then release **MODE** and **ENTER**.



is displayed.

5. Run the standard *Autoadjustment* function.
  - Make sure that the remote level is activated.

**For linear actuators<sup>1</sup>:**

- Press and hold **MODE**. Wait until the countdown has run down from 5 to 0, then release **MODE**.
- Press and hold **MODE** again until the countdown has run down from 3 to 0, then release **MODE**.

Standard *Autoadjustment* is started automatically, and the progress is displayed.

**For rotary actuators<sup>1</sup>**

- Press and hold **ENTER**.



- Wait until the display has changed to



- Release **ENTER**.
- Press and hold **ENTER** again until the countdown has run down from 3 to 0.
- Release **ENTER**.

Standard *Autoadjustment* is started automatically, and the progress is displayed.

When standard *Autoadjustment* has completed successfully, the determined parameters are saved automatically, and the remote level is activated again.

If, however, an error should occur during standard *Autoadjustment*, error code 255 is briefly indicated. The device then automatically changes over to parameter P1.1 *Autoadjust* (custom autoadjustment) at the configuration level.

- Press and hold **MODE**.
- Additionally, briefly press **↑** or **↓** several times until.



- Release **MODE**. CANCEL is displayed. If not, briefly press **↑** or **↓**.
- Press and hold **ENTER** until the countdown has run down from 3 to 0.

The positioner automatically returns to the operating level. Press and hold **MODE** and additionally briefly press **↑** twice to reach operating mode 1.3 "Manual adjustment within the sensor range". Then check the positioner-actuator assembly for proper mounting.

---



1. The zero position is automatically determined and saved by the standard autoadjustment function: turning counter-clockwise (CTCLOCKW) for linear and clockwise (CLOCKW) for rotary actuators.

Re-adjust if required (see chapter 3.1.3 or chapter 3.1.4 for details) and then start standard *Autoadjustment* again.

### 3.5.2 Requesting bus information

Additional information about the bus can be called up for display by briefly pressing the buttons shown in the table when bus mode is active (i.e. the following display is seen):









Buttons pressed	Command/Action																				
	<p><b>Show setpoint value and state.</b>            The display shows the last valid setpoint value (SP_VALUE) and state (SP_STATE) from the transducer block for two seconds, each. Then the REMOTE display is seen again.            The setpoint value is indicated as a percentage.            The setpoint state is indicated as a code number, meaning the following:</p> <table border="0"> <thead> <tr> <th data-bbox="386 638 442 662"><b>Code</b></th> <th data-bbox="554 638 957 662"><b>Meaning (Status, sub-status, details)</b></th> </tr> </thead> <tbody> <tr> <td data-bbox="386 667 408 686">28</td> <td data-bbox="554 667 868 686">Bad, OutOfService, NotLimited</td> </tr> <tr> <td data-bbox="386 691 408 710">73</td> <td data-bbox="554 691 957 710">Uncertain, SubstituteValue, LowLimited</td> </tr> <tr> <td data-bbox="386 715 408 734">74</td> <td data-bbox="554 715 957 734">Uncertain, SubstituteValue, HighLimited</td> </tr> <tr> <td data-bbox="386 738 408 758">75</td> <td data-bbox="554 738 935 758">Uncertain, SubstituteValue, Constant</td> </tr> <tr> <td data-bbox="386 762 408 782">79</td> <td data-bbox="554 762 879 782">Uncertain, InitialValue, Constant</td> </tr> <tr> <td data-bbox="386 786 420 805">192</td> <td data-bbox="554 786 957 805">GoodCascade, NonSpecific, NotLimited</td> </tr> <tr> <td data-bbox="386 810 420 829">224</td> <td data-bbox="554 810 1002 829">GoodCascade, InitiateFaultState, NotLimited</td> </tr> </tbody> </table>	<b>Code</b>	<b>Meaning (Status, sub-status, details)</b>	28	Bad, OutOfService, NotLimited	73	Uncertain, SubstituteValue, LowLimited	74	Uncertain, SubstituteValue, HighLimited	75	Uncertain, SubstituteValue, Constant	79	Uncertain, InitialValue, Constant	192	GoodCascade, NonSpecific, NotLimited	224	GoodCascade, InitiateFaultState, NotLimited				
<b>Code</b>	<b>Meaning (Status, sub-status, details)</b>																				
28	Bad, OutOfService, NotLimited																				
73	Uncertain, SubstituteValue, LowLimited																				
74	Uncertain, SubstituteValue, HighLimited																				
75	Uncertain, SubstituteValue, Constant																				
79	Uncertain, InitialValue, Constant																				
192	GoodCascade, NonSpecific, NotLimited																				
224	GoodCascade, InitiateFaultState, NotLimited																				
	<p><b>Show current block mode.</b>            The display shows the current mode of the AO function block and the transducer block for approximately two seconds, each. Then the REMOTE display is seen again.</p> <p>The AO function block may have the following modes:</p> <table border="0"> <tbody> <tr> <td data-bbox="386 1013 487 1032">OOS_AO</td> <td data-bbox="554 1013 789 1032">AO block out of service</td> </tr> <tr> <td data-bbox="386 1037 487 1056">IMAN_AO</td> <td data-bbox="554 1037 879 1056">Initialization Manual of AO block</td> </tr> <tr> <td data-bbox="386 1061 487 1080">AUTO_AO</td> <td data-bbox="554 1061 756 1080">Automatic AO block</td> </tr> <tr> <td data-bbox="386 1085 487 1104">MAN_AO</td> <td data-bbox="554 1085 733 1104">Manual AO block</td> </tr> <tr> <td data-bbox="386 1109 487 1128">CAS_AO</td> <td data-bbox="554 1109 744 1128">Cascade AO block</td> </tr> <tr> <td data-bbox="386 1133 487 1152">LO_AO</td> <td data-bbox="554 1133 800 1152">Local Override AO block</td> </tr> <tr> <td data-bbox="386 1157 487 1176">RCAS_AO</td> <td data-bbox="554 1157 834 1176">Remote Cascade AO block</td> </tr> <tr> <td data-bbox="386 1181 487 1200">ROUT_AO</td> <td data-bbox="554 1181 812 1200">Remote Output AO block</td> </tr> </tbody> </table> <p>The transducer block may have the following modes:</p> <table border="0"> <tbody> <tr> <td data-bbox="386 1268 487 1287">OOS_TB</td> <td data-bbox="554 1268 733 1287">TB out of service</td> </tr> <tr> <td data-bbox="386 1292 487 1311">AUTO_TB</td> <td data-bbox="554 1292 700 1311">Automatic TB</td> </tr> </tbody> </table>	OOS_AO	AO block out of service	IMAN_AO	Initialization Manual of AO block	AUTO_AO	Automatic AO block	MAN_AO	Manual AO block	CAS_AO	Cascade AO block	LO_AO	Local Override AO block	RCAS_AO	Remote Cascade AO block	ROUT_AO	Remote Output AO block	OOS_TB	TB out of service	AUTO_TB	Automatic TB
OOS_AO	AO block out of service																				
IMAN_AO	Initialization Manual of AO block																				
AUTO_AO	Automatic AO block																				
MAN_AO	Manual AO block																				
CAS_AO	Cascade AO block																				
LO_AO	Local Override AO block																				
RCAS_AO	Remote Cascade AO block																				
ROUT_AO	Remote Output AO block																				
OOS_TB	TB out of service																				
AUTO_TB	Automatic TB																				
<b>ENTER</b> 	<p><b>Show software revision level and device type</b></p>																				

### 3.5.3 Local operation (bus device)

#### Procedure for mode selection from operating level:

- Press and hold **MODE**.
- Additionally briefly press **↑** as often as required.  
The selected operating mode is indicated.
- Release **MODE**.
- The position is indicated as a percentage or rotation angle.

#### Overview

Mode	Mode display	Position display
<b>1.1</b> Positioning with fixed setpoint. Setpoint can be adjusted by pressing <b>↑</b> or <b>↓</b> .		
<b>1.2</b> Manual adjustment* within the operating range. Press <b>↑</b> or <b>↓</b> to adjust.**		
<b>1.3</b> Manual adjustment* within the sensor range. Press <b>↑</b> or <b>↓</b> to adjust.**		

\*) Positioning not active

\*\*\*) For quick motion: Press **↑** and **↓** together.

### 3.5.4 Parameter setting example



An overview of the parameter settings that can be changed via the front panel keypad is found in Appendix A.

#### IMPORTANT

#### "Changing zero position (of the LCD) from clockwise to counter-clockwise"

Starting situation: the positioner is operating remote-controlled.

1. Change over from the remote level to the operating level:
  - Press and hold **MODE** and **ENTER** simultaneously.
  - Wait until the countdown has run down from 3 to 0.
  - Release **MODE** and **ENTER**. Mode 1.1 is reached and indicated.
2. Change over to the configuration level:
  - Simultaneously press and hold **↑** and **↓**.
  - In addition, briefly press **ENTER**.
  - Wait until countdown from 3 to 0 has run down.
  - Release **↑** and **↓**.



is displayed.

3. Change over to parameter group 3.\_:
  - Simultaneously press and hold **MODE** and **ENTER**.
  - In addition 2 x briefly press **↑**.

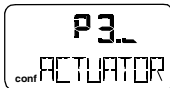

is displayed.

- Release **MODE** and **ENTER**.



is displayed.

4. Select parameter 3.2 "Zero position":

- Press and hold **MODE**.
- In addition, 2 x briefly press **↑**.



is displayed.

- Release **MODE**.

5. Change parameter setting:
  - Briefly press **↑** to select "CTCLOCKW".
6. Change over to parameter 3.3 "EXIT" and save the new setting:
  - Press and hold **MODE**.
  - In addition, 1 x briefly press **↑**.



is displayed.

- Release **MODE**.
- Briefly press **↑** to select "NV\_SAVE".
- Press and hold **ENTER** until the displayed countdown from 3 to 0 has run down.

The positioner saves the new settings and automatically returns to the operating level.

7. Return to the remote level.
  - Press and hold **MODE** and **ENTER**.
  - Wait until the countdown has run down from 3 to 0.
  - Release **MODE** and **ENTER**.



is displayed (percentage is an example)

### 3.6 Functional test / maintenance



#### WARNING

**Do not make any changes to devices with explosion protection.**



#### IMPORTANT

You should be aware of the fact that the positioner's warranty will expire immediately if you should modify or manipulate the electronics of a positioner without explosion protection.

The TZIDC-120 positioner is virtually maintenance free.

To ensure error-free and maintenance-free operation always supply the positioner with instrument air exempt from oil, water and dust according to DIN/ISO 8573-1 (purity and oil content acc. to Class 3, pressure dew point 10 K below the operating temperature).

We recommend to check the integrated air filter on a regular basis and replace it if required.

If the optionally installed filter regulator is installed, it has to be checked regularly as well. Additionally, the control position should be checked periodically for conformity with the tolerance limit.

### 3.6.1 Functional test of the shutdown module



#### WARNING

If the optional shutdown module is used, it must be subject to a functional test every two years at the latest to ensure full operational reliability in compliance with DIN V 19250. Otherwise, the AK4 approval will lapse.

Proceed as described below:

1. Remove the cover.
2. Alternately set the slide switch (1) from the "On" position in the middle to the top and bottom position ("Off1" or "Off2") and check that the actuator is depressurized properly.

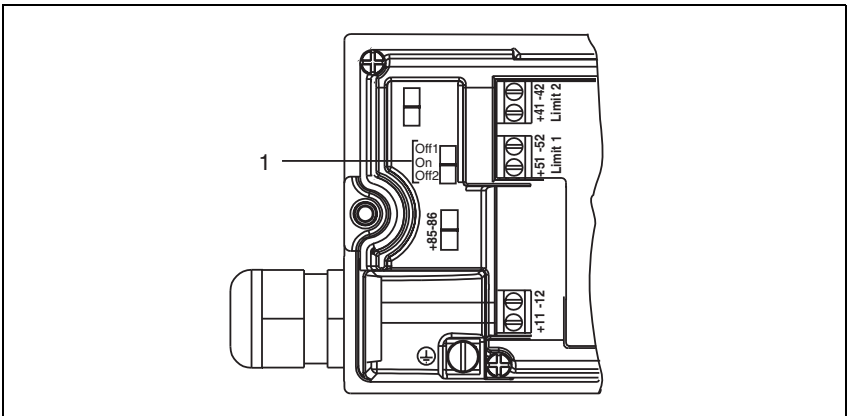

Fig. 21 Slide switch (service switch) of the shutdown module

3. Set the slide switch to the "On" position in the middle again.
4. Replace the cover.



## 4 Technical data

### 4.1 Fieldbus specifications

#### Physical

Specification	FOUNDATION Fieldbus™ Revision 1.5
Physical layer, profile class	Device type 113, 121 (IEC 61158-2)
Communication speed	31.25 Kbit/second
Current rating	11.5 mA
Fault current	15 mA (11.5 mA + 3.5 mA)
Operating voltage	Bus-powered: 9.0 V DC to 32.0 V DC
Max. withstand voltage	35 V DC
ATEX-certified for FISCO	Yes
Polarity-sensitiveness	Not sensitive to polarity reversal

#### Communications

Class	LM profile 32L, 31PS
Number of free VCRs	23 (No. of VCRs of which the application can be changed, except for the VCR used for management)

#### User layer

Function blocks provided	1 AO Function Block, 1 PID Block
Execution time	AO Block: 40 ms; PID Block: 50 ms
Block class	AO Block: standard; PID Block: enhanced Resource Block: enhanced; Transducer Block: custom
Number of linkage objects	22
Device description (DD)	Rev. No. 1 (file name: 0201.ffo, 0201.sym)
File	Common file format (file name: 020101.cff)
FF Certification	Registered with ITK 4.51, Dec. 2003 IT Camp. Number IT023200
Documentation	Configuration and parameter setting instructions, 45/18-82 EN
Support of "Incremental DD"	No
Calibration and diagnostic information defined in DD	Yes
Support of self-tuning	Supports self-tuning of the working range on the valve. Control loop "self-tuning" through the PID function block is not supported.
Delivery state	The positioner is delivered in an unadjusted state. The standard autoadjustment function has to be run to adapt the working range and control parameters. Otherwise the transducer block will remain in "Out of service" mode.
Diagnostic capabilities	Self-diagnostic of positioner hardware and software. Basic valve diagnostics incl. extended alarm handling

## 4.2 Basic model

### Name

#### Device tag

ABB POSITIONER TZIDC-120 xxxxxx

#### Device ID

0003200028\_\_\_\_\_TZIDC-120 xxxxxx

#### Device address

Between 10 and 247, default node address 23

### Output

#### Range

0...6 bar (0...90 psi)

#### Air capacity

at supply pressure of 1.4 bar (20 psi)

5.0 kg/h = 3.9 Nm<sup>3</sup>/h = 2.3 scfm

at supply pressure of 6 bar (90 psi)

13 kg/h = 10 Nm<sup>3</sup>/h = 6.0 scfm

(Booster, for increasing air capacity, on request)

#### Output function

for single or double acting actuators,

air is vented from actuator or actuator is blocked in case of an electrical power failure

#### Shut-off values

end position 0 % = 0...45 %

end position 100 % = 55...100 %

### Travel

#### Angle of rotation

Used range 25...120 ° (rotary actuators, optionally 270°)

25...60 ° (linear actuators)

#### Travel time prolongation

Range of 0...200 seconds, separately for each direction

### Air supply

#### Instrument air

free of oil, water and dust to DIN/ISO 8573-1

pollution and oil content according to Class 3

purity: max. particle size 5 µm, max. particle density 5 mg/m<sup>3</sup>;

oil content: max. concentration 1 mg/m<sup>3</sup>;

pressure dew point: 10 K below operating temperature

#### Supply pressure

1.4...6 bar (20...90 psi)

**NOTICE:** Do not exceed the actuator's max. operating pressure!

#### Air consumption

< 0.03 kg/h (0.015 scfm) (independent of supply pressure)

## Transmission data and influences

### Output 1)

Increasing:            increasing signal 0...100 %  
                             increasing output pressure OUT 1  
Decreasing:           increasing signal 0...100 %  
                             decreasing output pressure OUT 1

### Action (signal)

Direct                    signal 4...20 mA = position 0...100%  
Reverse                 signal 20...4 mA = position 0...100 %

### Characteristic deviation

≤ 0.5 %

### Tolerance band

0.3...10 %, adjustable

### Dead band

0.1...10 %, adjustable

### Resolution (A/D conversion)

> 16,000 steps

### Sample rate

20 msec

### Influence of ambient temperature

≤ 0.5 % for every 10 °C change in temperature

### Influence of vibration

≤ +/-1 % up to 10 g and 80 Hz

### Seismic requirements

Meets requirements of DIN/IEC 68-3-3 Class III for strong and strongest earthquakes

### Influence of mounting orientation

No effect

### Meets the requirements of the following directives

EMC Directive 89/336/EEC as of May 1989  
EC Directive for CE conformity marking

## Environmental capabilities

### Ambient temperature

-40 °C to +85 °C for operation, storage and transport  
-25 °C to +85 °C when using proximity switches SJ2-S1N (NO)

### Relative humidity

Operational (with closed case and air supply switched on):  
95 % (annual average), condensation permissible  
Transport and storage:  
75 % (annual average), non-condensing

## **Case**

### **Material/Protections**

Aluminum, protection class IP 65 (NEMA 4X)

### **Surface/color**

Electrostatic dipping varnish with epoxy resin, stove-hardened

Case varnished black, RAL 9005, matt,

Cap Pantone 420

### **Electrical connections**

Screw terminals:

max. 1.0 mm<sup>2</sup> for options, max. 2.5 mm<sup>2</sup> for bus connection

NOTICE: Do not expose the terminals to strain!

Cable entry

2 threads 1/2-14 NPT or M20x1.5

for cable diameter 6...12 mm

(1 with cable gland and 1 with pipe plug)

### **Pneumatic connections**

Threads G 1/4 or 1/4-18 NPT

### **Weight**

1.7 kg

### **Mounting orientation**

any orientation allowed

### **Dimensions**

see dimensional drawings in data sheet 10/18-0.34 EN

## Explosion protection



**WARNING**

The values indicated here have been taken out of the respective approval certificates.

Always observe the specifications and supplements in the certificates (see chapter "Certificates" starting on page 40).

### FM/CSA

(pending)

#### ATEX

Examination certificate

Type:

Device group:

Temperature class:

Perm. amb. temperature:



**II 2G EEx ia II C T6**

TÜV 02 ATEX 1834 X

Intrinsically safe equipment

II 2G (EEx ia IIC)

T4, T5, T6

T4:  $-40\text{ °C} \leq T_{\text{amb}} \leq 85\text{ °C}$

T5:  $-40\text{ °C} \leq T_{\text{amb}} \leq 55\text{ °C}$

T6:  $-40\text{ °C} \leq T_{\text{amb}} \leq 40\text{ °C}$

#### ATEX

Examination certificate

Type:

Device group:

Temperature class:

Perm. amb. temperature:



**II 3G EEx n A II T6**

TÜV 02 ATEX 1943 X

Explosion-proof equipment (Zone 2)

II 3G (EEx n A II)

T4, T5, T6

T4:  $-40\text{ °C} \leq T_{\text{amb}} \leq 85\text{ °C}$

T5:  $-40\text{ °C} \leq T_{\text{amb}} \leq 65\text{ °C}$

T6:  $-40\text{ °C} \leq T_{\text{amb}} \leq 50\text{ °C}$

#### IECEx

Examination certificate

Type:

Temperature class:

Perm. amb. temperature:



**Ex ia IIC T6**

IECEx TUN 04.0015X, Issue No.: 0

Intrinsically safe

T4, T5, T6

T4:  $-40\text{ °C} \leq T_{\text{amb}} \leq 85\text{ °C}$

T5:  $-40\text{ °C} \leq T_{\text{amb}} \leq 55\text{ °C}$

T6:  $-40\text{ °C} \leq T_{\text{amb}} \leq 40\text{ °C}$

Signal current circuit for FOUNDATION Fieldbus™, only for connection to a certified intrinsically safe circuit (e.g. FISCO power unit or barrier) with the following max. values:

	FISCO power supply ia/ib for group IIB/IIC	FISCO power supply ia/ib for group IIB/IIC	Barrier or power supply ia/ib for group IIB/IIC
Voltage	$U_i = 17.5\text{ V}$	$U_i = 17.5\text{ V}$	$U_i = 24\text{ V}$
Current	$I_i = 380\text{ mA}$	$I_i = 360\text{ mA}$	$I_i = 250\text{ mA}$
Power	$P_i = 5.32\text{ W}$	$P_i = 2.52\text{ W}$	$P_i = 1.2\text{ W}$
Characteristic line	rectangular	trapezoidal	linear

## 4.3 Options

### Module for the shutdown function

Supply voltage	24 V DC (20...30 V DC) (electrically isolated from the input signal)
Safe position activated when	voltage < 5 V
AK approval	AK 4 to DIN V 19250
Test report No.	101/S01/148
Explosion protection	see chapter "Certificates" starting on page 40

A separate 24 V DC signal is normally applied to the shutdown module, which connects through the signal from the microprocessor to the I/P module. When the 24 V DC signal is interrupted, the I/P module executes the respective safety function, depending on the mechanical construction.

#### Fail safe:

The positioner output 1 is depressurized, and the valve moves to the safe position. In case of a double-acting actuator the second output is additionally pressurized.

#### Fail-freeze:

The pneumatic output 1 is closed, and the valve "freezes" in its current position. In case of a double-acting actuator both outputs are closed.

The shutdown module works independently of the mother board, i.e. all information from the final control element is available in the supervisory process control system at any time.

### Digital position feedback with proximity switches <sup>1</sup>

2 proximity switches for independent position signaling.

Switching points adjustable between 0 and 100 %

Current circuits to DIN 19234 / NAMUR

Supply voltage 5...11 V DC

Signal current < 1 mA logical "0"

Signal current > 2 mA logical "1"

Direction of action (logical state):

Proximity switch	Position			
	< Lim. 1	> Lim. 1	< Lim. 2	> Lim. 2
SJ2-SN (NC)	0	1	1	0
SJ2-S1N (NO)	1	0	0	1



#### NOTICE

When using proximity switch type SJ2-S1N (NO) the TZIDC-120 positioner may be exposed to an ambient temperature of -25 °C ... +85 °C, only.

- 
1. The 'digital position feedback' option is directly actuated by the rotating shaft of the positioner and can only be used together with the (optional) mechanical position indicator.

### **Digital position feedback with 24 V microswitches <sup>1</sup>**

Two microswitches for independent position signaling.

Switching points adjustable between 0 and 100 %

Voltage max. 24 V AC / DC

Current load max. 2 A

Contact surface 10 µm gold (AU)

### **Mechanical position indicator**

Indicator disk in enclosure cover, linked with positioner feedback shaft

- 
1. The 'digital position feedback' option is directly actuated by the rotating shaft of the positioner and can only be used together with the (optional) mechanical position indicator.

## 5 Certificates



Translation

### (1) EC-TYPE EXAMINATION CERTIFICATE

- (2) Equipment or protective system intended for use in potentially explosive atmospheres - **Directive 94/9/EC**
- (3) EC-Type Examination Certificate Number



#### TÜV 02 ATEX 1834 X

- (4) Equipment: Positioner type TZID-C120 resp. TZID-C220
- (5) Manufacturer: ABB Automation Products GmbH
- (6) Address: Schillerstrasse 72  
D-32425 Minden
- (7) This equipment or protective system and any acceptable variation thereto is specified in the schedule to this certificate and the documents therein referred to.
- (8) The TÜV NORD CERT GmbH & Co. KG, TÜV CERT-Certification Body, notified body number N° 0032 in accordance with Article 9 of the Council Directive of the EC of March 23, 1994 (94/9/EC), certifies that this equipment or protective system has been found to comply with the Essential Health and Safety Requirements relating to the design and construction of equipment and protective systems intended for use in potentially explosive atmospheres given in Annex II to the Directive.

The examination and test results are recorded in the confidential report N° 02 YEX 164933.

- (9) Compliance with the Essential Health and Safety Requirements has been assured by compliance with:
- EN 50 014:1997**                      **EN 50 020:1994**
- (10) If the sign "X" is placed after the certificate number, it indicates that the equipment or protective system is subject to special conditions for safe use specified in the schedule to this certificate.
- (11) This EC-type examination certificate relates only to the design, examination and tests of the specified equipment in accordance to the Directive 94/9/EC. Further requirements of the Directive apply to the manufacturing process and supply of this equipment. These are not covered by this certificate.
- (12) The marking of the equipment or protective system must include the following:



**II 2 G EEx ia IIC T6**

TÜV NORD CERT GmbH & Co. KG  
TÜV CERT-Certification Body  
Am TÜV 1  
D-30519 Hannover  
Tel.: 0511 986-1470  
Fax: 0511 986-2555

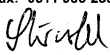
  
Head of the  
Certification Body



Hanover, 2002-05-08

TÜV CERT A4 04.02 10.000 L6

This certificate may only be reproduced without any change, schedule included.  
Excerpts or changes shall be allowed by the TÜV NORD CERT GmbH & Co. KG

page 1/3



(13)

## SCHEDULE

(14) **EC-TYPE EXAMINATION CERTIFICATE N° TÜV 02 ATEX 1834 X**

(15) Description of equipment

The positioner type TZID-C120 resp. TZID-C220 is used for the control resp. closed loop control of pneumatically driven valves. The reference value is transmitted via field bus. A integrated position sensor detects the current position of the valve drive.

An integrated current/pressure transformer (I/P) is used for the control of the pneumatic auxiliary power.

The permissible ambient temperature range in dependence on the temperature class has to be taken from the following table:

Temperature class	Ambient temperature range
T4	- 40 °C to + 85 °C
T5	- 40 °C to + 55 °C
T6	- 40 °C to + 40 °C

### Electrical data

Input circuit  
(terminal +11, -12 resp. +, -)

in type of protection „Intrinsic Safety“ EEx ia IIC  
resp. EEx ib IIC  
only for the connection to a certified intrinsically safe circuit (e.g. FISCO power supply) with the maximum values according to the following table:

	FISCO power supply ia / ib for group IIB / IIC	FISCO power supply ia / ib for group IIB / IIC	Barrier or power supply ia / ib for group IIB / IIC
Voltage	17.5 V	17.5 V	24 V
Current	380 mA	360 mA	250 mA
Power	5.32 W	2.52 W	1.2 W
Characteristic line	rectangular	trapezoidal	linear

$L_i$  negligibly small  
 $C_i$  negligibly small

Circuit for shutdown function  
(terminal +85 and -86)

in type of protection „Intrinsic Safety“ EEx ia IIC  
resp. EEx ib IIC  
only for the connection to certified intrinsically safe circuits with the maximum values of:  
 $U_i = 30 \text{ V}$

$C_i = 3.7 \text{ nF}$   
 $L_i$  negligibly small



Circuit for digital position  
feedback with proximity switches  
resp. Limit2 +41, -42)

maximum values see EG-type examination certificate  
No. PTB 00 ATEX 2049 X

Local communication interface (LKS)  
and programming interface (X5)

for the connection to the programmer resp. PC  
outside of the hazardous area

(16) Test documents are listed in the test report No.: 02 YEX 164933.

(17) Special conditions for safe use

The operation of the local communication interface (LKS) and of the programming interface (X5) is only allowed outside of the hazardous explosive area.

(18) Essential Health and Safety Requirements

no additional ones

Translation



1. SUPPLEMENT to

**EC TYPE-EXAMINATION CERTIFICATE No. TÜV 02 ATEX 1834 X**

of the company: ABB Automation Products GmbH  
Schillerstraße 72  
D-32425 Minden

In the future the Positioner type TZID-C120 resp. TZID-C220 may also be manufactured according to the test documents listed in the test report. The modifications refer to the internal construction as well as the extended type designation. This reads type TZIDC-120 resp. TZIDC-220. Further on the „Special conditions for safe use“ were amended.

All other data remain unchanged.

- (16) Test documents are listed in the test report N° 03 YEX 551065-1.
- (17) Special conditions for safe use  
Variants, which also comply with the type of protection „Flameproof Enclosure“ according to a separate certificate, may not be operated intrinsically safe after use as apparatus in the type of protection „Flameproof Enclosure“.
- (18) Essential Health and Safety Requirements  
no additional ones

TÜV NORD CERT GmbH & Co. KG  
TÜV CERT-Certification Body  
Am TÜV 1  
D-30519 Hannover  
Tel.: 0511 986-1470  
Fax: 0511 986-2555

Hanover, 2003-11-25

A handwritten signature in black ink, appearing to read 'P. Kroll'.

Head of the  
Certification Body



Translation

## STATEMENT OF CONFORMITY

- (1)
- (2) Equipment or Protective System intended for use in potentially explosive atmospheres - **Directive 94/9/EC**
- (3) Test certificate number



### TÜV 02 ATEX 1943 X

- (4) Equipment: Positioner type TZID-Cxxx
- (5) Manufacturer: ABB Automation Products GmbH
- (6) Address: Schillerstraße 72  
D-32425 Minden
- (7) This equipment and any acceptable variation thereto is specified in the schedule to this certificate and the documents therein referred to.
- (8) The TÜV NORD CERT GmbH & Co. KG, TÜV CERT-Certification Body, notified body number N° 0032 in accordance with Article 9 of the Council Directive 94/9/EC of March 23, 1994, certifies that this equipment or protective system has been found to comply with the Essential Health and Safety Requirements relating to the design and construction of equipment and protective systems intended for use in potentially explosive atmospheres given in Annex II to the Directive.

The examination and test results are recorded in confidential report N° 02YEX 182036.

- (9) Compliance with the Essential Health and Safety Requirements has been assured by compliance with:  
**EN 50021:1999**
- (10) If the sign "X" is placed after the certification number, it indicates that the equipment or protective system is subject to special conditions for safe use specified in the schedule to this certificate.
- (11) This statement of conformity certificate relates only to the design, examination and tests of the specified equipment in accordance to the Directive 94/9/EC. Further requirements of the Directive apply to the manufacturing process and supply of this equipment or protective system. These are not covered by this certificate.
- (12) The marking of the equipment or protective system shall include the following:

 II 3 G EEx n A II T6

TÜV NORD CERT GmbH & Co. KG  
TÜV CERT-Certification Body  
Am TÜV 1  
D-30519 Hannover  
Tel.: 0511 996 4470  
Fax: 0511 996 2555

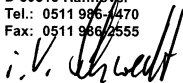

Head of the  
Certification Body

Hanover, 2002-10-26



TÜV CERT A4 07.01 10.000 L6

This statement of conformity may only be reproduced without any change, schedule included.  
Excerpts or changes shall be allowed by the TÜV NORD CERT GmbH & Co. KG

page 1/3



(13) **SCHEDULE**

(14) **STATEMENT OF CONFORMITY N° TÜV 02 ATEX 1943 X**

(15) Description of equipment or protective system

The positioner type TZID-Cxxx is used for the control resp. closed loop control of pneumatically actuated valves.

The positioner type TZID-C110 resp. TZID-C110 transfers the reference value via a field bus signal.

The positioner type TZID-C transfers the reference value via a current loop of 4 ... 20 mA.

The positioner type TZID-Cxxx may be installed in explosion hazardous areas that require apparatus of the category 3.

The permissible ambient temperature range in dependence of the temperature class has to be taken from the following table:

Temperature class	Ambient temperature range
T6	-40°C to +50°C
T5	-40°C to +65°C
T4	-40°C to +85°C

Electrical data

**Type TZID-C**

Signal circuit ..... U = 8,7 V d. c.; 4 ... 20 mA, max. 21,5 mA  
(Terminals 12[-], 11[+])

Digital input ..... U = 12 ... 24 V DC, 4mA  
(Terminals 82[-], 81[+])

Digital output ..... U = 11 V DC  
(Terminals 84[-], 83[+])

**Options for TZID-C**

Circuit for  
analog position feedback .... U = 10 ...30 V d. c.; 4 ... 20 mA, max. 21,5 mA  
(Terminals 32[-], 31[+])

Circuit for  
digital position feedback .....U = 5 ... 11 V d. c.  
(Terminals 42[-], 41[+]  
resp. 52[-], 51[+])

**Type TZID-C110**

Input circuit ..... U = 9 ... 32 V d. c.; 10,5 mA  
(Terminals 12[-], 11[+])



Schedule statement of conformity N° TÜV 02 ATEX 1943 X

---

**Type TZID-C120**

Input circuit ..... U = 9 ... 32 V d. c.; 11,5 mA  
(Terminals 12[-], 11[+])

**Options for all Types**

Circuit for  
shutdown function..... U = 20 ... 30 V d. c.  
(Terminals 86[-], 85[+])

Circuit for digital  
position feedback with  
proximity switches ..... U = 5 ... 11 V d. c.  
(Terminals Limit 1 52[-], 51[+]  
resp. Limit 2 42[-], 41[+])

- (16) Test documents are listed in the test report no. 02YEX182036.
- (17) Special conditions for safe use
1. Only devices, which are suitable for the operation in explosion hazardous areas of the zone 2 and the conditions available at the place of operation (Declaration of conformity or certificate of a testing department), are allowed to be connected to non intrinsically safe circuits in the zone 2.
  2. The connecting and disconnecting as well as the switching of circuits under voltage, is only permitted during installation, for maintenance or for repair purposes.  
Note: The temporal coincidence of explosion hazardous atmosphere and installation, maintenance resp. repair purposes is assessed as unlikely.
  3. For the circuit "digital position feedback with proximity switches" measures have to be taken outside the device, that the rated voltage is exceeded not more than 40% by transient disturbances.
  4. Only non combustible gases are allowed to be used as pneumatic auxiliary energy.
  5. Only suitable cable entries, which meet the requirements of EN 50 021, are allowed to be used.
- (18) Essential Health and Safety Requirements
- no additional ones



# IECEX Certificate of Conformity

## INTERNATIONAL ELECTROTECHNICAL COMMISSION IEC Certification Scheme for Explosive Atmospheres

for rules and details of the IECEx Scheme visit [www.iecex.com](http://www.iecex.com)

Certificate No.: **IECEX TUN 04.0015X** Issue No.: **0**

Status: **Current**

Date of Issue: **2004-07-29** Page 1 of 4

Applicant: **ABB Automation Products GmbH**  
Schillerstraße 72  
32425 Minden  
Germany

Electrical Apparatus: **Positioner type TZIDC-xxx**  
*Optional accessory:*

Type of Protection: **Intrinsic safety; Type of protection "n"**

Marking: **Ex ia IIC T6 resp. Ex nA II T6**

*Approved for issue on behalf of the IECEx  
Certification Body:*

Herbert Stürwold

*Position:*

Head of IECExCB

*Signature:  
(for printed version)*

*Date:*

\_\_\_\_\_  
\_\_\_\_\_

1. This certificate and schedule may only be reproduced in full.
2. This certificate is not transferable and remains the property of the issuing body.
3. The Status and authenticity of this certificate may be verified by visiting the [Official IECEx Website](http://www.iecex.com).

Certificate issued by:

**TÜV NORD CERT GmbH & Co. KG**

Am TÜV1  
D-30519 Hannover  
Germany





# IECEX Certificate of Conformity

Certificate No.: **IECEX TUN 04.0015X**

Date of Issue: **2004-07-29**

Issue No.: **0**

Page **2** of **4**

Manufacturer: **ABB Automation Products GmbH**  
Schillerstraße 72  
32425 Minden  
**Germany**

Manufacturing location(s):

**ABB**  
Automation Products GmbH  
Schillerstraße 72  
32425 Minden  
Germany

This certificate is issued as verification that a sample(s), representative of production, was assessed and tested and found to comply with the IEC Standard list below and that the manufacturer's quality system, relating to the Ex products covered by this certificate, was assessed and found to comply with the IECEx Quality system requirements. This certificate is granted subject to the conditions as set out in IECEx Scheme Rules, IECEx 02 and Operational Documents as amended.

#### STANDARDS:

The electrical apparatus and any acceptable variations to it specified in the schedule of this certificate and the identified documents, was found to comply with the following standards:

<b>IEC 60079-0 : 2000</b> Edition: 3.1	Electrical apparatus for explosive gas atmospheres - Part 0: General requirements
<b>IEC 60079-11 : 1999</b> Edition: 4	Electrical apparatus for explosive gas atmospheres - Part 11: Intrinsic safety 'i'
<b>IEC 60079-15 : 2001</b> Edition: 2	Electrical apparatus for explosive gas atmospheres - Part 15: Type of protection 'n'

*This Certificate **does not** indicate compliance with electrical safety and performance requirements other than those expressly included in the Standards listed above.*

#### TEST & ASSESSMENT REPORTS:

*A sample(s) of the equipment listed has successfully met the examination and test requirements as recorded in*

IECEX ATR:  
**DE/TUN/04/551542**

File Reference:  
**04 YEX 551542**





# IECEx Certificate of Conformity

Certificate No.: **IECEx TUN 04.0015X**

Date of Issue: **2004-07-29**

Issue No.: **0**

Page **3** of **4**

## Schedule

### EQUIPMENT:

*Equipment and systems covered by this certificate are as follows:*

The Positioner type TZIDC-xxx is used for the control resp. closed loop control of pneumatic driven valves. The Positioner type TZIDC resp. TZIDC-200 transfers the reference value by means of an impressed signal current of 4...20 mA.

The Positioner type TZIDC-110, TZIDC-210, TZIDC-120 resp. TZIDC-220 transfers the reference value via a field bus signal.

An integrated distance sensor measures the current position of the valve drive. An integrated current/pressure transformer (I/P) is used for the pneumatic auxiliary power.

The permissible ambient temperature range in dependence on the type, the type of protection and the Temperature Classes has to be taken from the following table:

Type and marking	TZIDC resp. TZIDC-200 Ex ib IIC	TZIDC-110/-210/ -120/-220 Ex ia IIC	TZIDC resp. TZIDC- 110/-120 Ex nA II
Temperature Class	Ambient temperature range		
T4	-40°C to +85°C	-40°C to +85°C	-40°C to +85°C
T5	-40°C to +50°C	-40°C to +55°C	-40°C to +65°C
T6	-40°C to +35°C	-40°C to +40°C	-40°C to +50°C

Additional technical data see EQUIPMENT (continued)

### CONDITIONS OF CERTIFICATION: YES as shown below:

Special condition for safe use of intrinsically safe Positioners:

The operation of the local communication interface (LKS) and of the programming interface (X5) is only allowed outside of the hazardous explosive area.

Special conditions for safe use of Positioners marked Ex nA II T6:

Only devices which are suitable for the operation in explosion hazardous areas declared as zone 2 and the conditions available at the place of operation are allowed to be connected to circuits in the zone 2.

The connecting and disconnecting as well as the switching of circuits under voltage are only permitted during installation, for maintenance or repair purposes.

Note: The temporal coincidence of explosion hazardous atmosphere and installation, maintenance resp. repair purposes is assessed as improbably.

For the circuit "Mechanical digital feedback" measures have to be taken outside the device that the rated voltage is exceeded not more than 40% by transient disturbances.

Only non combustible gases are allowed to be used as pneumatic auxiliary energy.

Only suitable cable entries which meet the requirements of IEC 60079-15 are allowed to be used.



# IECEx Certificate of Conformity

Certificate No.: **IECEx TUN 04.0015X**

Date of Issue: **2004-07-29**

Issue No.: **0**

Page **4** of **4**

**Additional information:**

<b>Electrical data for type TZIDC resp. TZIDC-200 with marking Ex ib IIC T6</b>	
Signal circuit (terminals 11(+), 12(-))	in type of protection "Intrinsic Safety" Ex ib IIC only for the connection to a certified intrinsically safe circuit with the following maximum values: $U_i = 30 \text{ V}$ $I_i = 320 \text{ mA}$ $P_i = 1.1 \text{ W}$ effective internal capacitance: $C_i = 6.6 \text{ nF}$ The effective internal inductance is negligibly small.
Switch input (terminals 81(+), 82(-))	in type of protection "Intrinsic Safety" Ex ib IIC only for the connection to a certified intrinsically safe circuit with the following maximum values: $U_i = 30 \text{ V}$ effective internal capacitance: $C_i = 3.7 \text{ nF}$ The effective internal inductance is negligibly small.
Switch output (terminals 83(+), 84(-))	in type of protection "Intrinsic Safety" Ex ib IIC only for the connection to a certified intrinsically safe circuit with the following maximum values: $U_i = 30 \text{ V}$ $P_i = 500 \text{ mW}$ effective internal capacitance: $C_i = 3.7 \text{ nF}$ The effective internal inductance is negligibly small.
Local interface for communication (LKS)	For the connection to a programmer outside of the explosive hazardous area.
Optionally the following modules are allowed to be used:	
Mechanical digital feedback (terminals Limit1 +51, -52 resp. Limit2 +41, -42)	in type of protection "Intrinsic Safety" Ex ib IIC Maximum values see IEC Certificate No. (proximity switches of the company Pepperl + Fuchs GmbH)
Digital feedback (terminals +51, -52 resp. +41, -42)	in type of protection "Intrinsic Safety" Ex ib IIC only for the connection to a certified intrinsically safe circuit with the following maximum values: $U_i = 30 \text{ V}$ $P_i = 500 \text{ mW}$ effective internal capacitance: $C_i = 3.7 \text{ nF}$ The effective internal inductance is negligibly small.
Analogue feedback (terminals +31, -32)	in type of protection "Intrinsic Safety" Ex ib IIC only for the connection to a certified intrinsically safe circuit with the following maximum values: $U_i = 30 \text{ V}$ $P_i = 1.1 \text{ W}$ effective internal capacitance: $C_i = 6.6 \text{ nF}$ The effective internal inductance is negligibly small.
Shutdown-switch-input (terminals +51, -52 resp. +85, -86)	in type of protection "Intrinsic Safety" Ex ib IIC only for the connection to a certified intrinsically safe circuit with the following maximum values: $U_i = 30 \text{ V}$ effective internal capacitance: $C_i = 3.7 \text{ nF}$ The effective internal inductance is negligibly small.
The intrinsically safe circuits themselves are safe galvanically separated up to a voltage of 60 V. The "Local interface for communication (LKS)" is connected with the signal circuit.	

<b>Electrical data for type TZIDC-110, TZIDC-210, TZIDC-120 resp. TZIDC-220 with marking Ex ia IIC T6</b>			
Input circuit (terminals +11, -12 resp. +, -)	in type of protection "Intrinsic Safety" Ex ia IIC resp. Ex ib IIC only for the connection to a certified intrinsically safe circuit (e.g. FISCO power supply) with the maximum values according to the following table:		
	FISCO power supply ia/ib for group IIB/IIC	FISCO power supply ia/ib for group IIB/IIC	Barrier or power supply ia/ib for group IIB/IIC
Voltage	17.5 V	17.5 V	24 V
Current	380 mA	360 mA	250 mA
Power	5.32 W	2.52 W	1.2 W
Characteristic line	rectangular	Trapezoidal	linear
Local interface for communication (LKS) and programming interface (X5)	For the connection to a programmer resp. a PC outside of the explosive hazardous area.		
Optionally the following modules are allowed to be used:			
Shutdown-switch-input (terminals +51, -52 resp. +85, -86)	in type of protection "Intrinsic Safety" Ex ia IIC resp. Ex ib IIC only for the connection to a certified intrinsically safe circuit with the following maximum values: $U_i = 30 \text{ V}$ effective internal capacitance: $C_i = 3.7 \text{ nF}$ The effective internal inductance is negligibly small.		
Mechanical digital feedback (terminals Limit1 +51, -52 resp. Limit2 +41, -42)	in type of protection "Intrinsic Safety" Ex ib IIC Maximum values see IEC Certificate No. (proximity switches of the company Pepperl + Fuchs GmbH)		
The intrinsically safe circuits themselves are safe galvanically separated up to a voltage of 60 V. The "Local interface for communication (LKS) and programming interface (X5)" is connected with the signal circuit.			

<b>Electrical data for type TZIDC, TZIDC-110 resp. TZIDC-120 with marking Ex nA II T6</b>	
<b>Type TZIDC resp. TZIDC-200</b>	
Signal circuit (terminals 11(+), 12(-))	U = 8.7 VDC; 4...20 mA, max. 21.5 mA
Switch input (terminals 81(+), 82(-))	U = 12...24 VDC; 4 mA
Switch output (terminals 83(+), 84(-))	U = 11 VDC
Optionally the following modules are allowed to be used with type TZIDC:	
Digital feedback (terminals +51, -52 resp. +41, -42))	U = 5...11 VDC
Analogue feedback (terminals +31, -32)	U = 10...30 VDC; 4...20 mA, max. 21.5 mA
<b>Type TZIDC-110</b>	
Input circuit (terminals +11, -12)	U = 9...32 VDC; 10.5 mA
<b>Type TZIDC-120</b>	
Input circuit (terminals +11, -12)	U = 9...32 VDC; 11.5 mA
Additionally the following modules are allowed to be used with all types marked Ex nA II T6:	
Shutdown-switch-input (terminals +51, -52 resp. +85, -86)	U = 20...30 VDC
Mechanical digital feedback (terminals Limit1 +51, -52 resp. Limit2 +41, -42)	U = 5...11 VDC



**EC-TYPE-EXAMINATION CERTIFICATE**  
(Translation)

- (2) Equipment and Protective Systems Intended for Use in Potentially Explosive Atmospheres - **Directive 94/9/EC**
- (3) EC-type-examination Certificate Number:



**PTB 00 ATEX 2049 X**

- (4) Equipment: SN-sensors, types NJ... and SJ...
- (5) Manufacturer: Pepperl + Fuchs GmbH
- (6) Address: D-68307 Mannheim
- (7) This equipment and any acceptable variation thereto are specified in the schedule to this certificate and the documents therein referred to.
- (8) The Physikalisch-Technische Bundesanstalt, notified body No. 0102 in accordance with Article 9 of the Council Directive 94/9/EC of 23 March 1994, certifies that this equipment has been found to comply with the Essential Health and Safety Requirements relating to the design and construction of equipment and protective systems intended for use in potentially explosive atmospheres, given in Annex II to the Directive.

The examination and test results are recorded in the confidential report PTB Ex 00-29268.

- (9) Compliance with the Essential Health and Safety Requirements has been assured by compliance with:  
**EN 50014:1997** **EN 50020:1994**
- (10) If the sign "X" is placed after the certificate number, it indicates that the equipment is subject to special conditions for safe use specified in the schedule to this certificate.
- (11) This EC-type-examination Certificate relates only to the design and construction of the specified equipment in accordance with Directive 94/9/EC. Further requirements of this Directive apply to the manufacture and supply of this equipment.
- (12) The marking of the equipment shall include the following:

**II 2 G EEx ia IIC T6**

Zertifizierungsstelle Explosionsschutz  
By order:

Braunschweig, October 05, 2000

Dr.-Ing. U. Johannsmeyer  
Regierungsdirektor



sheet 1/4

EC-type-examination Certificates without signature and official stamp shall not be valid. The certificates may be circulated only without alteration. Extracts or alterations are subject to approval by the Physikalisch-Technische Bundesanstalt. In case of dispute, the German text shall prevail.

Physikalisch-Technische Bundesanstalt • Bundesallee 100 • D-38116 Braunschweig

## SCHEDULE

(13)

(14) **EC-TYPE-EXAMINATION CERTIFICATE PTB 00 ATEX 2049 X**

(15) Description of equipment

The SN-sensors, types NJ... and SJ... are used to convert displacements into electrical signals.

The SN-sensors, types NJ... and SJ... may be operated with intrinsically safe circuits certified for categories and explosion groups [EEx ia] IIC or IIB resp. [EEx ib] IIC or IIB. The category as well as the explosion group of the SN-sensors depends on the connected supplying intrinsically safe circuit.

### Electrical data

#### Evaluation and

supply circuit..... type of protection Intrinsic Safety EEx ia IIC/IIB  
resp. EEx ib IIC/IIB

only for connection to certified intrinsically safe circuits  
maximum values:

type 1	type 2	type 3	type 4
$U_i = 16 \text{ V}$	$U_i = 16 \text{ V}$	$U_i = 16 \text{ V}$	$U_i = 16 \text{ V}$
$I_i = 25 \text{ mA}$	$I_i = 25 \text{ mA}$	$I_i = 52 \text{ mA}$	$I_i = 76 \text{ mA}$
$P_i = 34 \text{ mW}$	$P_i = 64 \text{ mW}$	$P_i = 169 \text{ mW}$	$P_i = 242 \text{ mW}$

The assignment of the type of the connected circuit to the maximum permissible ambient temperature and the temperature class as well as the effective internal reactances for the individual types of SN-sensors is shown in the following table:

sheet 2/4

EC-type-examination Certificates without signature and official stamp shall not be valid. The certificates may be circulated only without alteration. Extracts or alterations are subject to approval by the Physikalisch-Technische Bundesanstalt. In case of dispute, the German text shall prevail.

Physikalisch-Technische Bundesanstalt • Bundesallee 100 • D-38116 Braunschweig

types	C <sub>i</sub> [nF]	L <sub>i</sub> [µH]	type 1			type 2			type 3			type 4		
			maximum permissible ambient temperature in °C for application in temperature class											
			T6	T5	T4-T1	T6	T5	T4-T1	T6	T5	T4-T1	T6	T5	T4-T1
NJ 2-11-SN...	50	150	73	88	100	66	81	100	45	60	89	30	45	74
NJ 2-11-SN-G...	50	150	76	91	100	73	88	100	62	77	81	54	63	63
NJ 2-12GK-SN...	50	150	73	88	100	69	84	100	51	66	80	39	54	61
NJ 3-18GK-S1N...	70	200	73	88	100	69	84	100	51	66	80	39	54	61
NJ 4-12GK-SN...	70	150	73	88	100	69	84	100	51	66	80	39	54	61
NJ 5-18GK-SN...	120	200	73	88	100	69	84	100	51	66	80	39	54	61
NJ 5-30GK-S1N...	100	200	73	88	100	69	84	100	51	66	80	39	54	61
NJ 6-22-SN...	110	150	73	88	100	69	84	100	51	66	80	39	54	61
NJ 6-22-SN-G...	110	150	76	91	100	73	88	100	62	77	81	54	63	63
NJ 6S1+U.+N...	180	150	73	88	100	69	84	100	51	66	80	39	54	61
NJ 8-18GK-SN...	120	200	73	88	100	69	84	100	51	66	80	39	54	61
NJ 10-30GK-SN...	120	150	73	88	100	69	84	100	51	66	80	39	54	61
NJ 15-30GK-SN...	120	180	73	88	100	69	84	100	51	66	80	39	54	61
NJ 15S-U.-N...	180	150	73	88	100	66	81	100	45	60	89	30	45	74
NJ 20S-U.-N...	200	150	73	88	100	66	81	100	45	60	89	30	45	74
NJ 40-FP-SN...	370	300	73	88	100	66	81	100	45	60	89	30	45	74
SJ 2-SN...	30	100	73	88	100	66	81	100	45	60	78	30	45	57
SJ 2-S1N...	30	100	73	88	100	66	81	100	45	60	78	30	45	57
SJ 3,5-S1N...	30	100	73	88	100	66	81	100	45	60	89	30	45	74
SJ 3,5-SN...	30	100	73	88	100	66	81	100	45	60	89	30	45	74

(16) Test report PTB Ex 00-29268

(17) Special conditions for safe use

1. For the application within a temperature range of -60 °C to -20 °C the SN-sensors, types NJ... and SJ... must be protected against damage due to impact by mounting into an additional housing.
2. The connection facilities of the SN-sensors, types NJ... and SJ... shall be installed as such that at least a degree of protection of IP20 according to IEC-publication 60529:1989 is met.
3. The assignment of the type of the connected circuit to the maximum permissible ambient temperature and the temperature class as well as the effective internal reactances for the individual types of SN-sensors is shown in the table given under item (15) of this EC-type-examination certificate.

sheet 3/4

EC-type-examination Certificates without signature and official stamp shall not be valid. The certificates may be circulated only without alteration. Extracts or alterations are subject to approval by the Physikalisch-Technische Bundesanstalt. In case of dispute, the German text shall prevail.

Physikalisch-Technische Bundesanstalt • Bundesallee 100 • D-38116 Braunschweig



4. With the application in group IIC inadmissible electrostatic charge of the plastic housing has to be avoided for following types of SN-sensors (warning label on the device):

NJ 40-FP-SN...

5. Inadmissible electrostatic charge of parts of the metal housing has to be avoided for the following types of SN-sensors. Dangerous electrostatic charges of parts of the metal housing can be avoided by grounding of these parts whereas very small parts of the metal housing (e.g. screws) don't need to be grounded:

NJ 2-11-SN-G...

NJ 6-22-SN-G...

NJ 6S1+U3+N...

NJ 6S1+U4+N...

NJ 15S+U3+N...

NJ 15S+U4+N...

NJ 20S+U3+N...

NJ 20S+U4+N...

NJ 40-FP-SN-P3...

NJ 40-FP-SN-P4...

(18) Essential health and safety requirements

Met by the standards mentioned above

Zertifizierungsstelle Explosionsschutz

By order:

Dr.-Ing. U. Johannsmeyer  
Regierungsdirektor



Braunschweig, October 05, 2000

sheet 4/4

EC-type-examination Certificates without signature and official stamp shall not be valid. The certificates may be circulated only without alteration. Extracts or alterations are subject to approval by the Physikalisch-Technische Bundesanstalt. In case of dispute, the German text shall prevail.

Physikalisch-Technische Bundesanstalt • Bundesallee 100 • D-38116 Braunschweig

## Appendix A: Configuration overview

Par.	Display	Function	Parameter setting	Unit	Factory setting
P1_	STANDARD				
P1.0	ACTUATOR	Actuator type	LINEAR, ROTARY	-	LINEAR
P1.1	AUTO_ADJ	Autoadjustment	Action	-	-
P1.2	TOL_BAND	Tolerance band	0.3...10.0	%	0.8
P1.3	DEADBAND	Deadband	0.1...5.0	%	0.5
P1.4	TEST	Test	Action	-	-
P1.5	<i>not used</i>				
P1.6	EXIT	Return to operat. level	Action	-	-
P2_	SETPOINT				
P2.0	<i>not used</i>	-			
P2.1	<i>not used</i>	-			
P2.2	CHARACT	Characteristic curve	LINEAR, EP 1:25, 1:50,25:1, 50:1, USERDEF,	-	LINEAR
P2.3	ACTION	Output action	DIRECT, REVERSE	-	DIRECT
P2.4	SHUT_CLS	Shut close value 0%	OFF, 0.1...45.0	%	OFF
P2.5	RAMP_UP	Setpoint ramp, up	OFF, 0.1...999.9	sec	OFF
P2.6	RAMP_DN	Setpoint ramp, down	OFF, 0.1...999.9	sec	OFF
P2.7	SHUT_OPN	Shut open value 100 %	OFF, 80.0...100.0	%	OFF
P2.8	EXIT	Return to operat. level	Action	-	-
P3_	ACTUATOR				
P3.0	MIN_RGE	Min. of operat. range	0.0...100.0	%	0.0
P3.1	MAX_RGE	Max. of operat. range	0.0...100.0	%	100.0
P3.2	ZERO_POS	Zero position	CLOCKWISE, CTCLOCKWISE	-	CTCLOCKWISE
P3.3	EXIT	Return to operat. level	Action	-	-
P4_ and P5_		<i>not used</i>	<i>not used</i>		

Par.	Display	Function	Parameter setting	Unit	Factory setting
P6._	MAN_ADJ				
P6.0	MIN_VR	Min. valve range	0.0...100.0	%	0.0
P6.1	MAX_VR	Max. valve range	0.0...100.0	%	100.0
P6.2	ACTUATOR	Actuator type	LINEAR, ROTARY	-	LINEAR
P6.3	SPRNG_Y2	Spring action (Y2)	CLOCKWISE, CTCLOCKWISE	-	CTCLOCKWISE
P6.4	ADJ_MODE	Autoadjust mode	FULL, STROKE, CTRL_PAR, ZERO_POS, LOCKED	-	FULL
P6.5	EXIT	Return to operat. level	Action	-	-
P7._	CTRL_PAR				
P7.0	KP UP	KP value, up	1.0...100.0	-	1.0
P7.1	KP DN	KP value, down	1.0...100.0	-	1.0
P7.2	TV UP	TV value, up	0...1000	msec	100
P7.3	TV DN	TV value, down	0...1000	msec	100
P7.4	GOPLS UP	Go pulse, up	0...200	msec	0
P7.5	GOPLS DN	Go pulse, down	0...200	msec	0
P7.6	Y-OFS UP	Y offset, up	Y-Min...100.0	%	40.0
P7.7	Y-OFF DN	Y offset, down	Y-Min...100.0	%	40.0
P7.8	<i>not used</i>	<i>not used</i>	<i>not used</i>	-	-
P7.9	TOL_BAND	Tolerance band	0.3...10.00	%	0.8
P7.10	TEST	Test	Action	-	-
P7.11	EXIT	Return to operat. level	Action	-	-
P8._, P9._, P10._		<i>not used</i>	<i>not used</i>		
P11._	FS / IP				
P11.0	FAIL_POS	Safe position	ACTIVE, INACTIVE	-	INACTIVE
P11.1	FACT_SET	Factory setting	Action	-	-
P11.2	IP_TYP	I/P module type	NO_F_POS, F_SAFE_1, F_SAFE_2, F_FREEZE1, F_FREEZE_2	-	NO_F_POS
P11.3	EXIT	Return to operat. level	Action	-	-

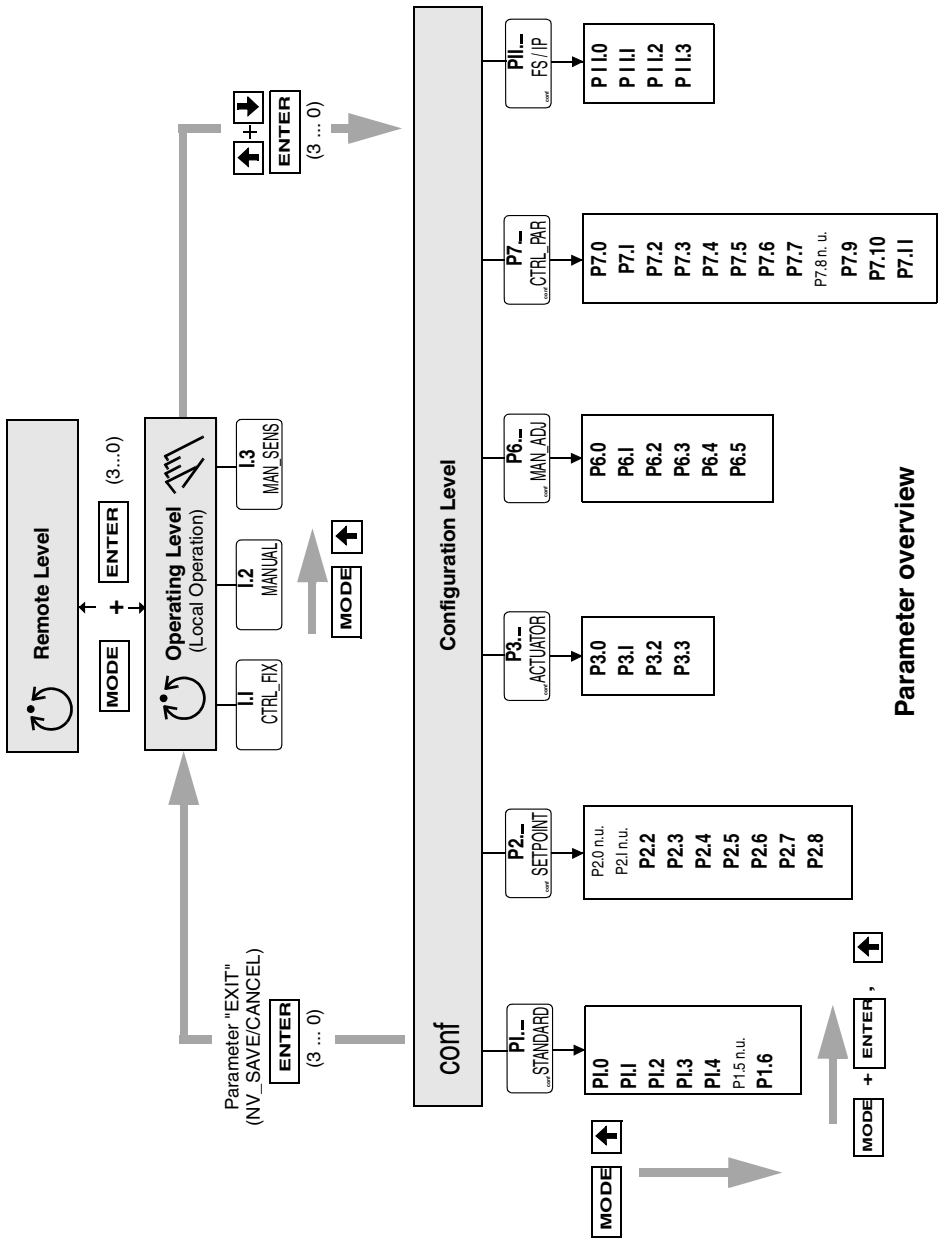

**Parameter overview**



**VALVE ACCESSORIES & CONTROLS**

200 Jade Park • Chelsea, AL 35043

TEL: 205.678.0507

[info@vacaccessories.com](mailto:info@vacaccessories.com)