

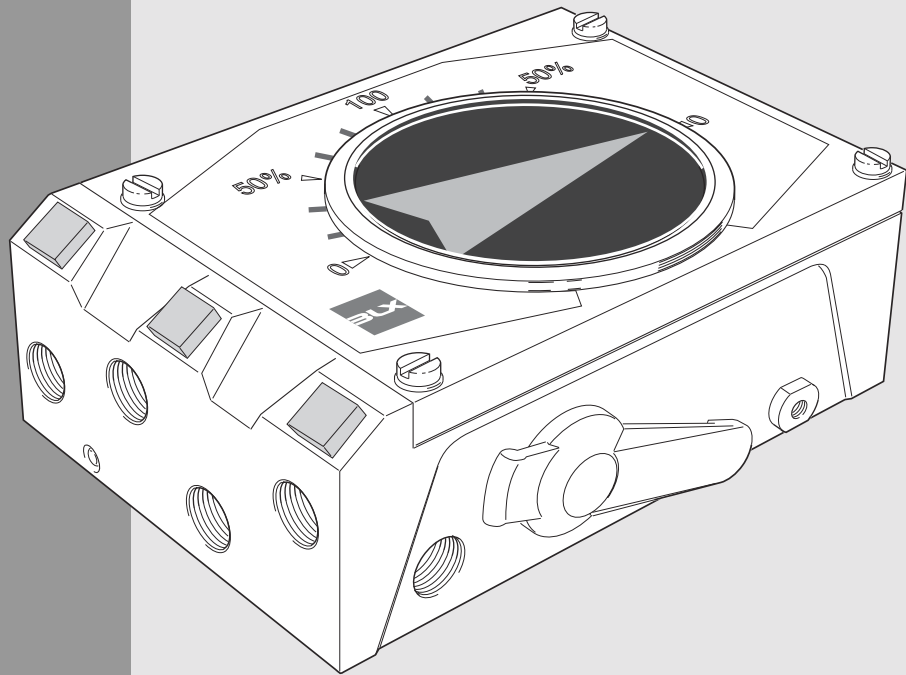

Made in Sweden

Valve Accessories & Controls.

V100 POSITIONER



**Installation,
Operating and
Maintenance
instruction.**



V100 Positioner

CONTENTS

1 INTRODUCTION	2
1.1 General	2
1.2 Function	2
1.3 Product Identification	3
1.4 Air quality recommendations	3
1.5 Safety Instructions	4
2 INSTALLATION	5
2.1 Connections.....	6
2.2 General mounting instructions	6
2.2.1 Mounting on rotary actuators	6
2.2.2 Mounting on linear actuators	6
2.3 Installation instructions for rotary actuators	7
2.3.1 Double acting	7
2.3.2 Single acting	7
2.4 Installation instructions for linear actuators	8
2.4.1 Double acting	8
2.4.2 Single acting	8
2.5 Cam	9
2.5.1 Adjustments	9
2.5.2 Cam specifications	9
2.6 4-20 mA connection	10
2.6.1 Connecting the control signal	10
2.6.2 Checking the control signal	10
2.6.3 Bench test with calibrator	10
2.7 Calibration	11
3 MAINTENANCE	12
3.1 Front cover and Indicator	12
3.2 Pilot valve	13
3.3 I/P-converter, type EA1	14
3.4 Filter	15
3.5 Membrane	16
3.6 Feed back spring, changing	17
3.7 Feed back spring, disassembly	18
3.8 Balance arm	19
3.9 Guide arm, changing	20
3.10 Guide arm, disassembly	21
3.11 Drive shaft	22
3.12 Drive	23
3.13 Safety valve	24
4 CONVERTING	25
4.1 V100P to V100E	25
5 SPARE PARTS	26
5.1 Exploded drawing	26
5.2 Spare parts list	27
6 TECHNICAL INFO	28
6.1 Specifications	28
6.2 Dimensions	29



V100 Positioner

Thank you for choosing the BLX V100 positioner

1. INTRODUCTION

1.1 General.

BLX V100 is a compact, modular positioner for both rotary and linear actuators, double or single acting.

There are two basic types: V100P for a pneumatic signal and V100E for a current signal.

BLX V100 has independent zero and span adjustments, making calibration very simple. External access for zeroing is standard.

BLX V100 corrosion resistant painting and sealing meet NEMA 4X as well as the sealing requirement IP 66.

BLX V100 is furnished standard with four connections for gauges and a threaded opening for venting the positioner's exhaust.

The BLX R100 feedback unit for the V100 is offered as an accessory (see separate manual).

1.2 Function

The V100 utilizes the force balance principal of operation. The desired value, in the form of pressure, affects the membrane(1) with the force that is created transferred to the balance arm(2). The opposing force, which represents the actual value, is provided by the feedback spring(5) and works in the opposite direction on the balance arm(2). The feedback spring, resting on the guide arm(3), is positioned by the shape and response of the cam. The cam(4) is connected to the cylinder's (actuator) piston rod via the drive.

The pilot valve(6) is connected to the balance arm and follows the balance arm's movement. The system is stable when the spool(7) is in the neutral position and the forces that affect the balance arm is in equilibrium. As soon as a signal change or a change in the position of the piston rod occurs, the force balance is also changed and the spool moves. Air immediately begins to flow into the part of the cylinder (C+ or C-) which allows the feedback mechanism to return the spool to the neutral position. The system is self-stabilizing and searches for equilibrium.

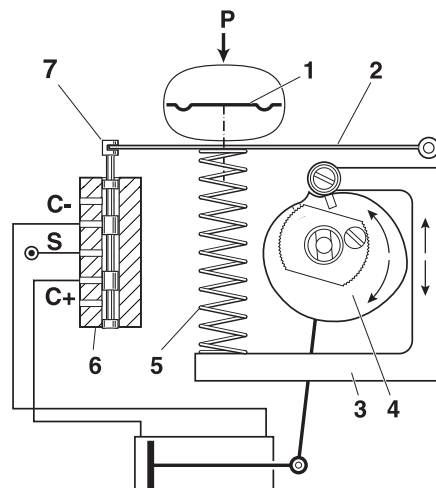
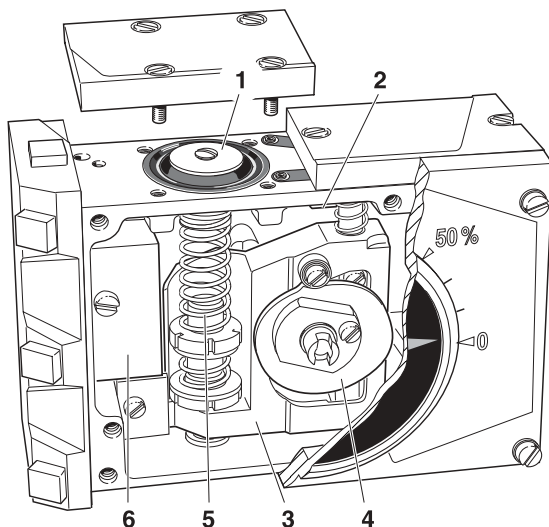



V100 Positioner

1.3 Product identification

The V100 has two identification tags, the serial number tag(1), and the product model tag(2). The latter contains information on control signal, maximum working pressure and temperature ranges. Other information can be shown depending on the model.

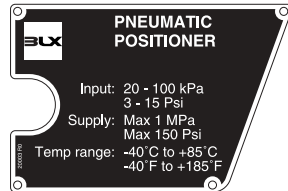
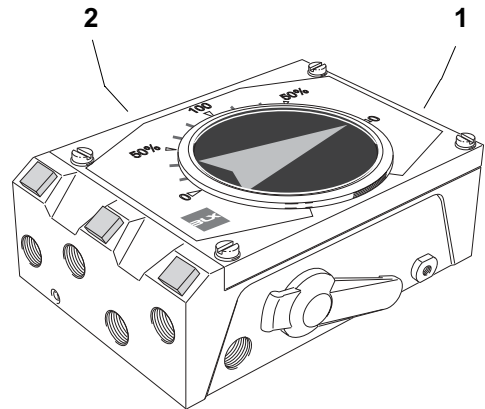

The product model tag for V100P



The serial number tag

1.4 Air quality recommendations

Poor air quality is one of the causes of premature functional problems with pneumatic and electro-pneumatic equipment. The pilot valve and I/P-converter are precision instruments and are therefore the most sensitive parts of the positioner.

a) Water in the supply air is a natural occurrence. This happens when air is compressed. The compression heats the air and the natural degree of water in the air can remain as moisture. When the air cools in pipes etc. the moisture condenses and becomes liquid water. Large quantities can build and sometimes flood small water separators. This excess water will eventually reach the control valve and positioner. This can cause corrosion damage to the I/P converter, causing the unit to malfunction.

We strongly recommend the use of water separators with adequate capacity. Coalescing filters from a reputable manufacturer is an inexpensive way to help prevent unit malfunctions or failures and add life to the product. These filters remove particles and moisture from air lines.

b) Oil in the supply air usually is from the main compressor. Oil can clog the small nozzles and disturb the flapper in the I/P-converter. It can also cause the spool to “drag” within the pilot valve. The result is poor control or in the worst case, failure.

c) Particles in the air usually occur because of corrosion. Dirt and particles can block the small nozzles of the I/P-converter. They can also cause the pilot valve to malfunction. The unit may completely fail.

To ensure normal operational safety with BLX positioner products, we recommend that a water separator and a <80 micrometer filter are mounted as close to the product as possible. If larger amount of oil is present an oil separator should be installed as well.

To further increase operational safety, we recommend that the working air is clean, dry and free of moisture, water, oil, particles and other contaminants, in accordance with the international standard ISA S7.3-81.



V100 Positioner

1.5 Safety Instructions



CAUTION: Beware of moving parts when positioner is operated!



CAUTION: Beware of parts with live voltage!

A voltage, which is normally not dangerous, is supplied to the positioner. Avoid touching live parts and bare wires as well as short circuiting live parts and the housing.



CAUTION: Do not dismantle a pressurized positioner!

Dismantling a pressurized positioner will result in uncontrolled pressure release. Always isolate the relevant part of the pipeline. Release the pressure from the positioner and the piping. Failure to do this may result in damage or personal injury.



CAUTION: Do not exceed the positioner performance limitations!

Exceeding the limitations marked on the positioner may cause damage to the positioner, actuator and valve. Damage or personal injury may result.



V100 Positioner

2. INSTALLATION

2.1 Connections

S – Supply air

V100P: max. 145 PSI / 1 MPa

V100E: 23 - 145 PSI / 0,15 -1 MPa

I_p – Input, pressure signal

V100P: 3-15 PSI / 20-100 kPa

V100E: Plugged

I_E – Input, current signal

V100E: 4-20 mA (Ri max 250 ohm)

V100P: Plugged

C+ - Cylinder connection + stroke

C- - Cylinder connection – stroke

EXHAUST - All air from the cylinder, I/P and positioner is vented through this port.

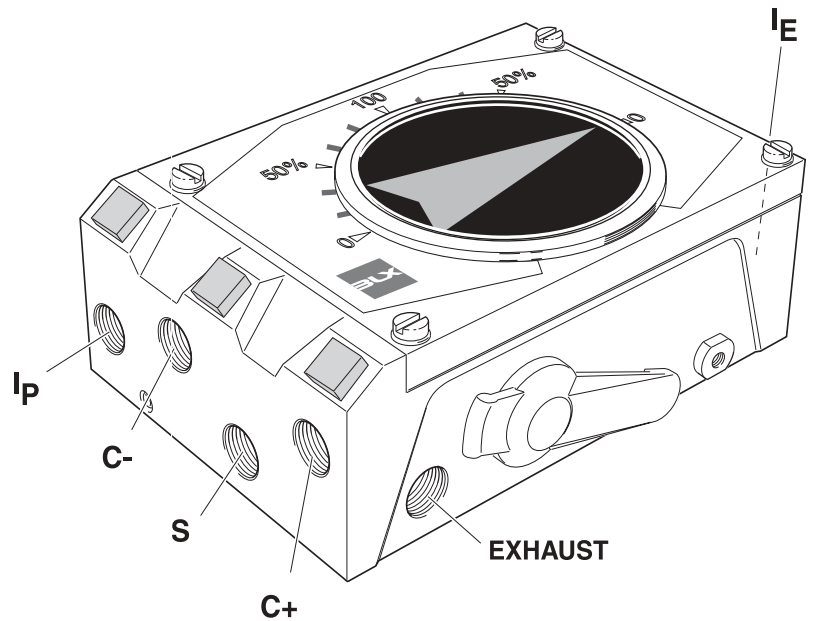

Air connections

for male 1/4" NPT or G 1/4".

Gauge connections

for male 1/8" NPT or G 1/8".

Cable entry

for male 1/2" NPT, PG 13.5
or M20 cable fitting.

The appropriate threads are clearly indicated by the markings on the housing.

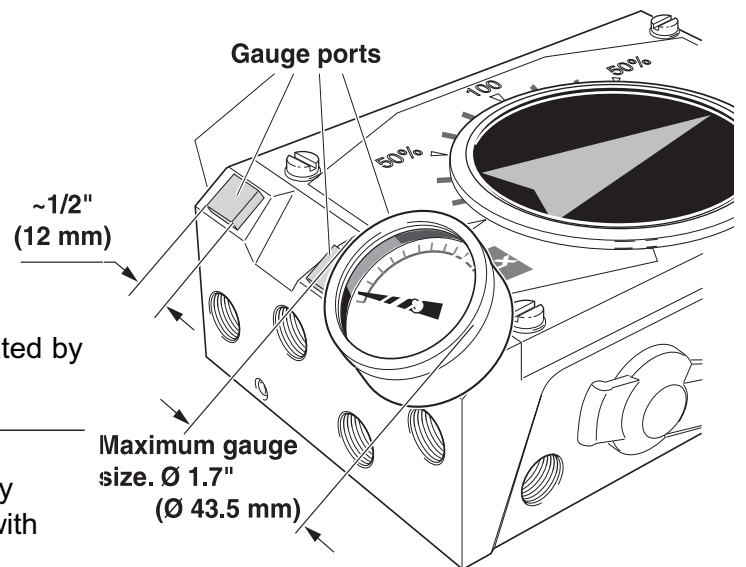

Gauge ports **I**, **C+**, **C-** and **S** are factory plugged. Remove the plugs and replace with gauges.



Liquid sealant for threads, Loctite or similar, is recommended for all air connections.



**The I_p connection must be plugged in V100E
The I_E connection should be plugged in V100P**



V100 Positioner

2.2 General mounting instructions.

The V100 has the ISO F05 hole pattern(1) for mounting kits.

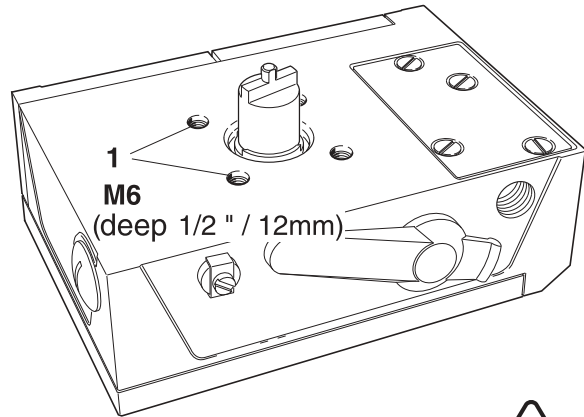

2.2.1 Rotary actuator

The BLX V100 has a very stable and properly sized drive shaft bearing. However, the positioner drive(A) should be aligned properly to the rotary actuator spindle(B). A relatively small error combined with a rigid coupling can create very powerful radial forces, which can in turn overload and in short time wear out even the very best drive shaft bearing.

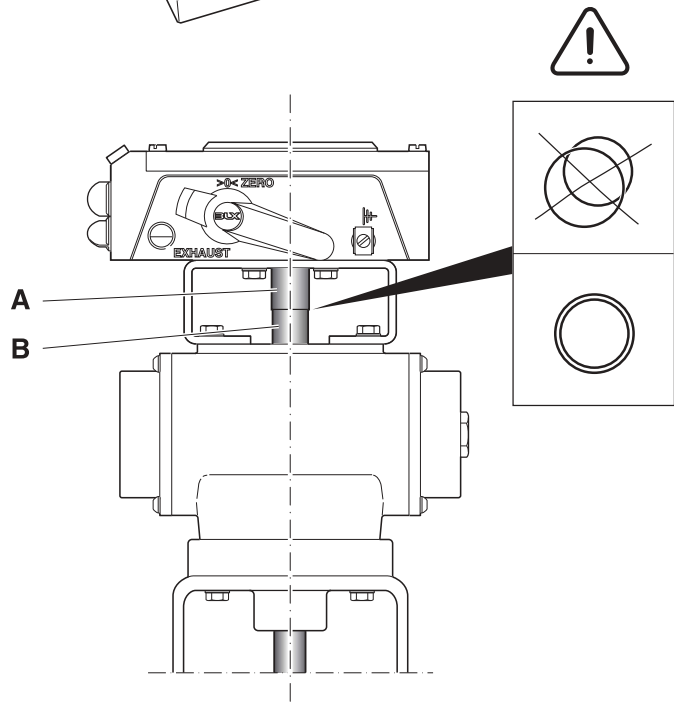

2.2.2 Linear actuator

When mounting on linear actuators, the positioner should be attached in such a way that its drive is in the center of the actuator's stroke. Proper installation and alignment will minimize linearity error.

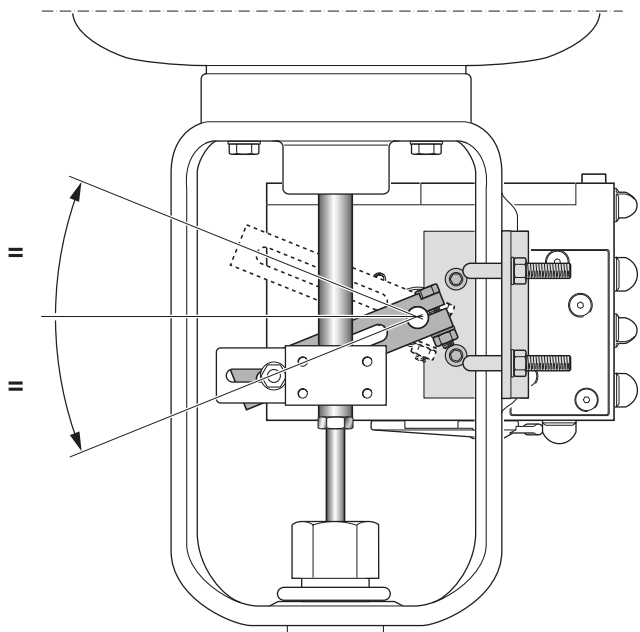



V100 Positioner

2.3 Installation instructions for rotary actuators

2.3.1 Double acting

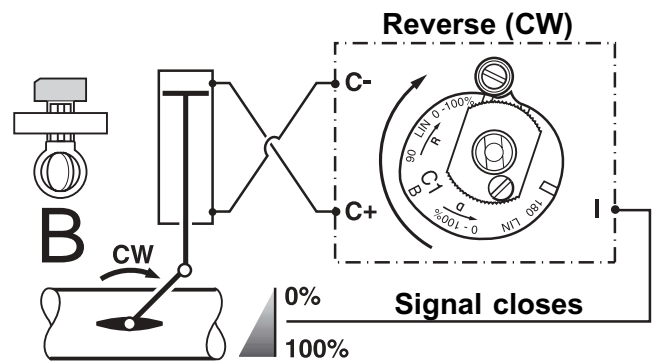
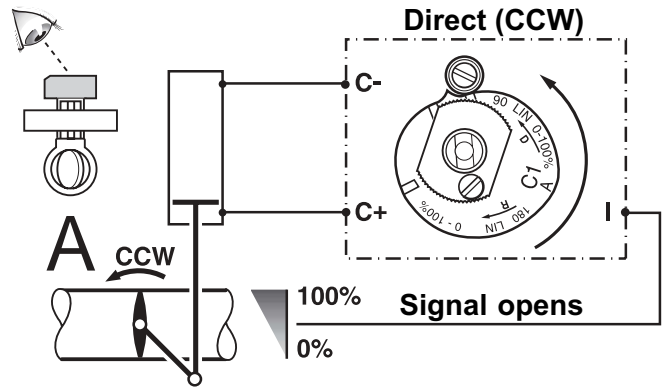

2.3.2 Single acting

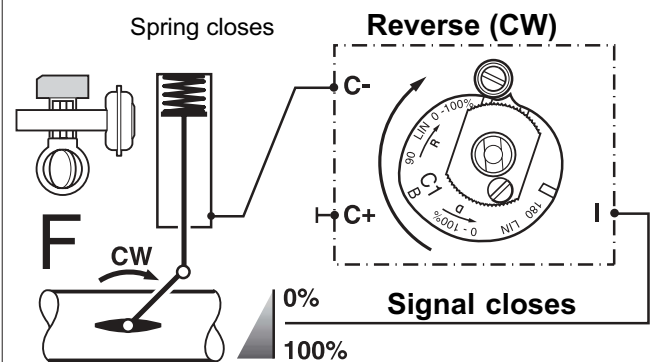
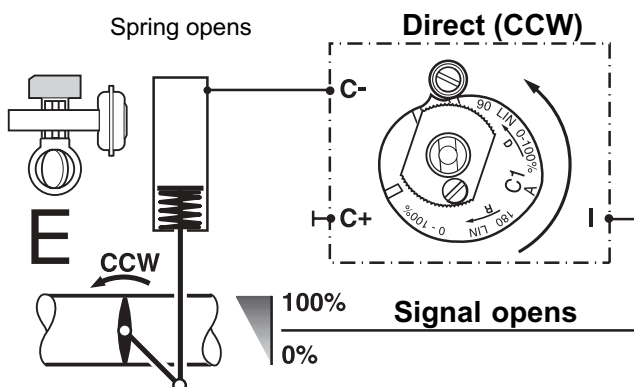
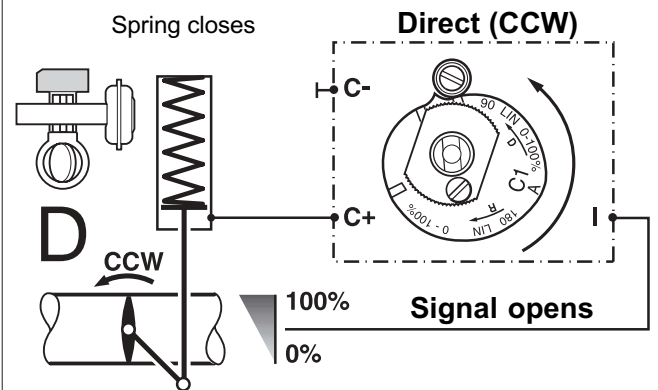
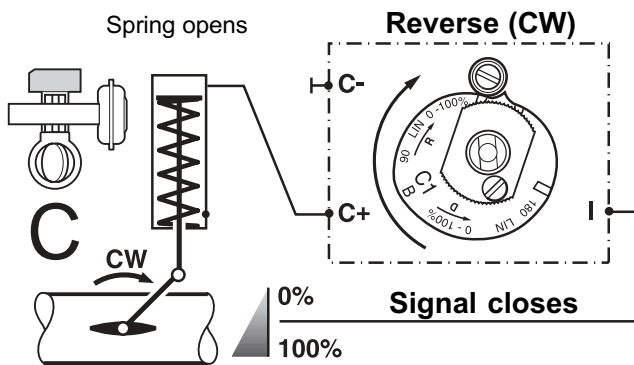



V100 Positioner

2.4 Installation instructions for linear actuators

2.4.1 Double acting

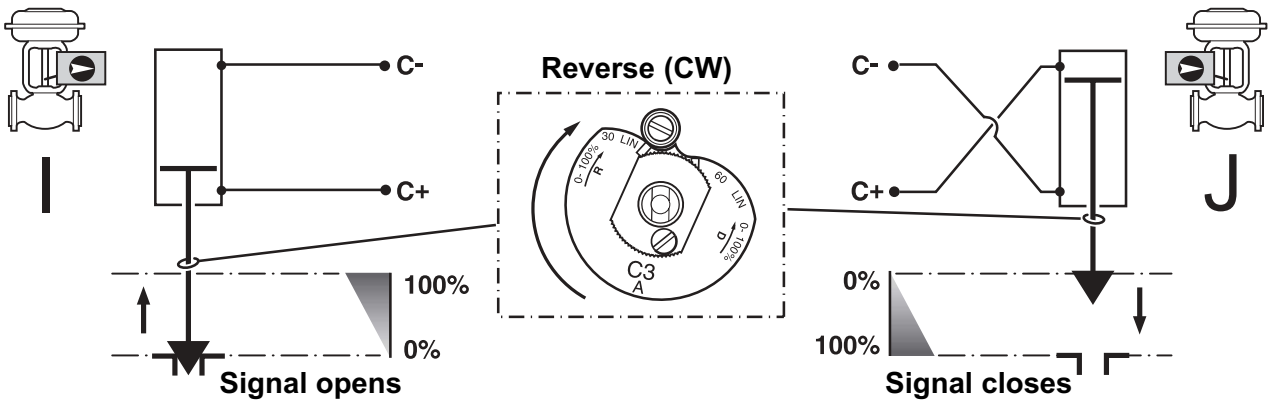
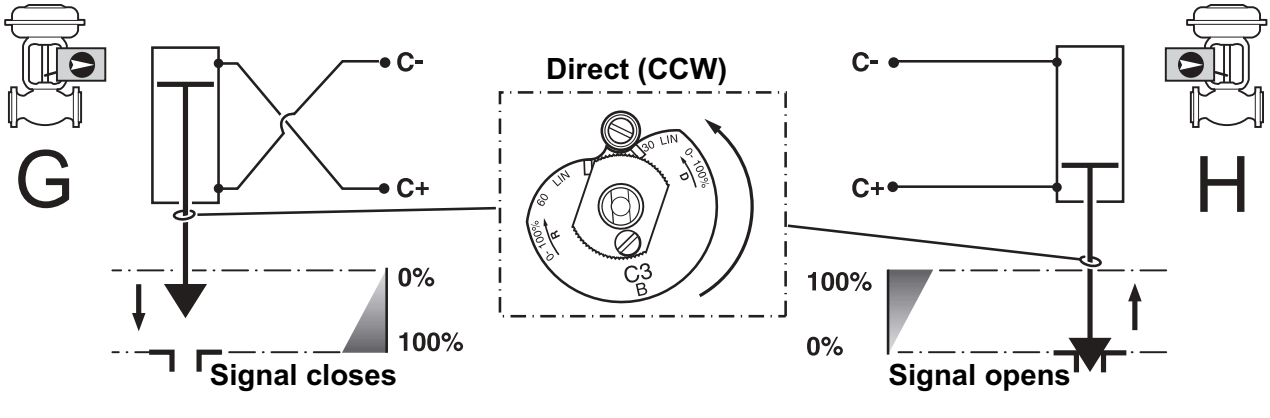

2.4.2 Single acting

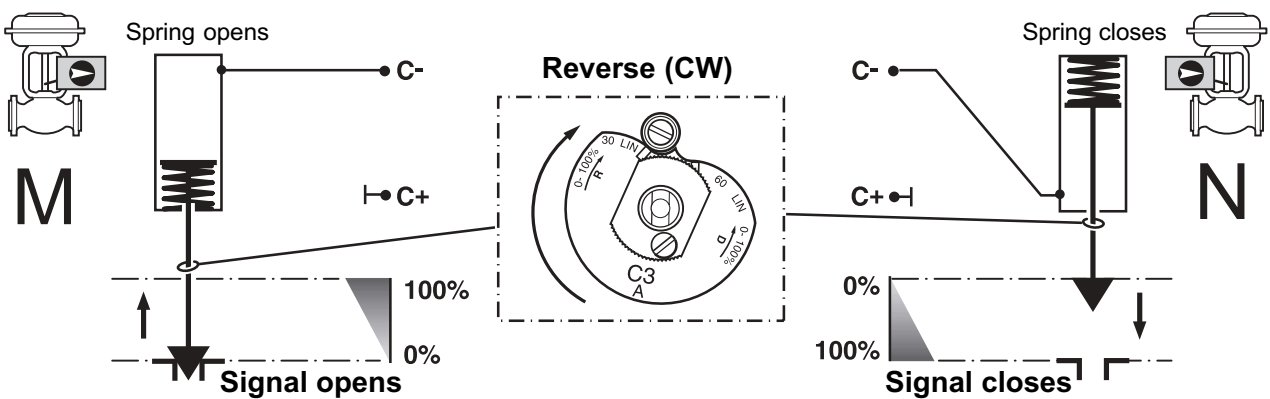
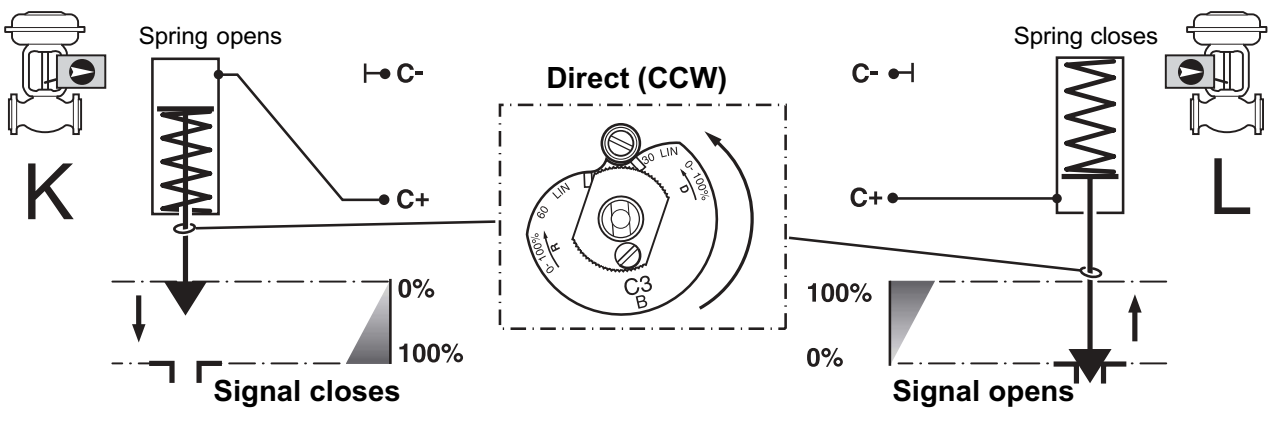



V100 Positioner

2.5 Cam



The V100 is standard shipped with the C1-cam, factory set for 90° ±1°, direct (CCW) turning.

2.5.1 Adjustments

Remove the front cover and indicator. (see page 12)

1. Loosen the lock screw(1) and the cam nut(2).
2. Run the valve/actuator to the stop/end position at 0% input.
3. Turn the cam(3) so that the index mark(5) for the selected curve aligns with the ball bearing(4).
4. Tighten the cam nut by hand(2).
Check that the lock screw(1) is still loose. (if not, loosen the lock screw slightly and tighten the nut again)
5. Tighten the lock screw(1).

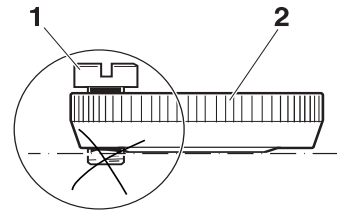
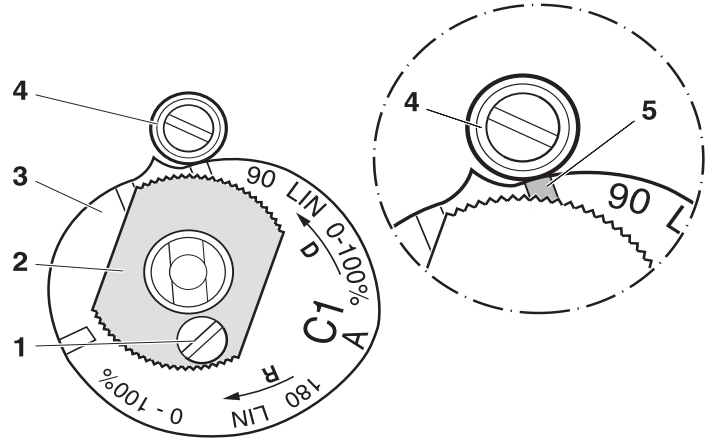

2.5.2 Cam specifications C1

Index mark / Starting point of rotation *

- | | | | |
|-----|------|----------------|-----------------|
| 5. | 90° | Linear 0-100% | CCW |
| 6. | 180° | Linear 0-100% | CW |
| 6. | 90° | Linear 0-50% | CW split range |
| 7. | 90° | Linear 50-100% | CW split range |
| 8. | 90° | Linear 0-100% | CW |
| 9. | 180° | Linear 0-100% | CCW |
| 9. | 90° | Linear 0-50% | CCW split range |
| 10. | 90° | Linear 50-100% | CCW split range |

*Increasing signal rotation

Most valves rotate CW to close / CCW to open

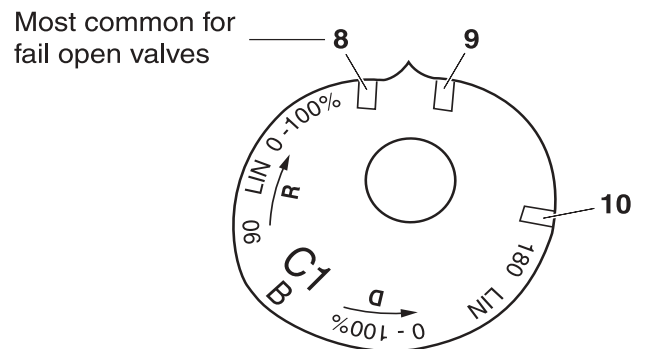
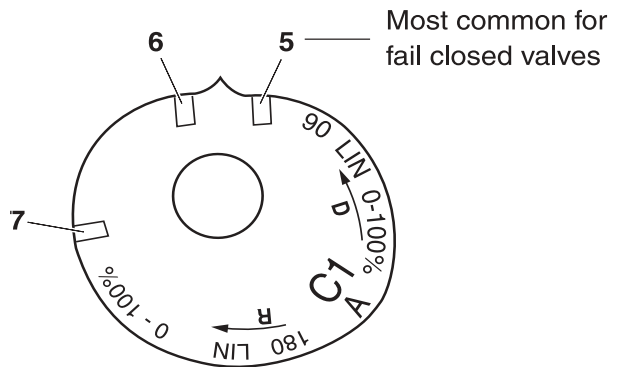

When field reversing action of positioner tubing must be reversed as well. (see page 7 and 8)



V100 Positioner

2.6 4-20 mA connection

2.6.1 Connecting the control signal

Remove the front cover and indicator.
(see page 12)

Loosen the screw(1) enough so that the connection card can be lifted.

Secure the connection card into the small slot(2).

Terminal block screws are now easily accessible.

Connect the cables to its respective pole.

Max cable area 2,5 mm², ~AWG 13

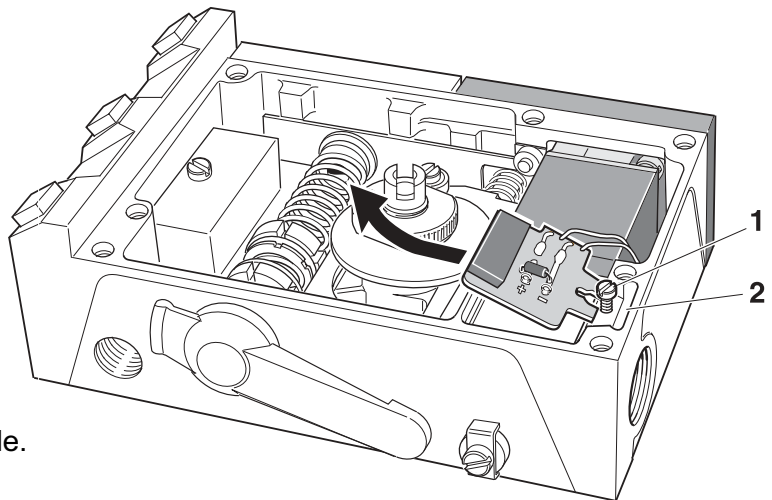

2.6.2 Checking the control signal

The control signal can be checked without having to break the signal loop. This is done by connecting a low ohmic ampere meter over the test points(3).

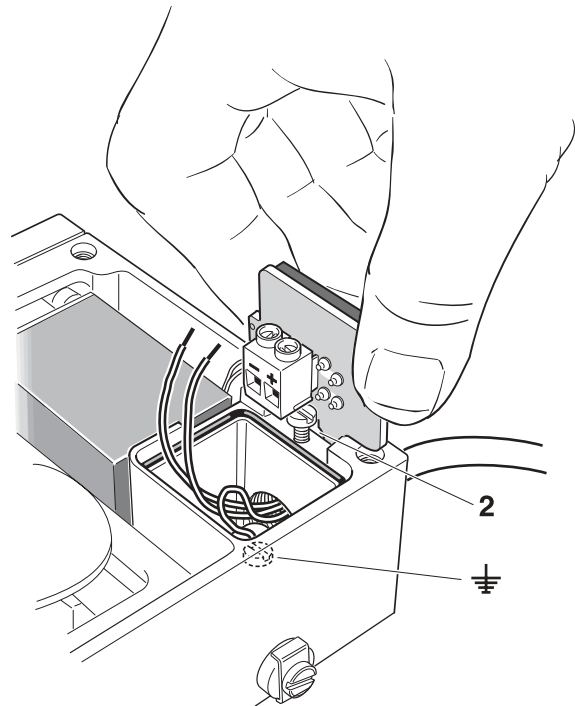

2.6.3 Bench test with the calibrator

When bench testing, it is possible to connect the control signal over the points(4) without having to loosen the connection card.

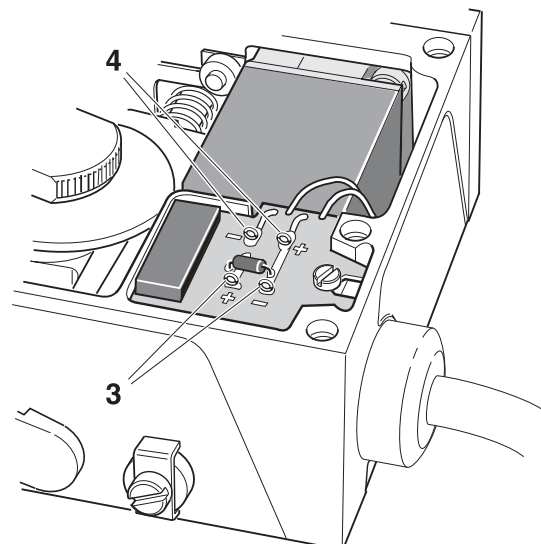

The I/P-converter is factory-adjusted. No extra range or zeroing adjustments are necessary.



V100 Positioner

2.7 Calibration

 **The V100 is delivered factory calibrated 0-100 % \pm 1%.**

Calibration procedure

Zero position

1. Set 0% input signal.
2. Wait until the valve has adjusted.
3. Adjust the zero position by turning the zeroing screw(3), with a screw-driver from the outside or by using a slot(3a) on the yellow wheel.

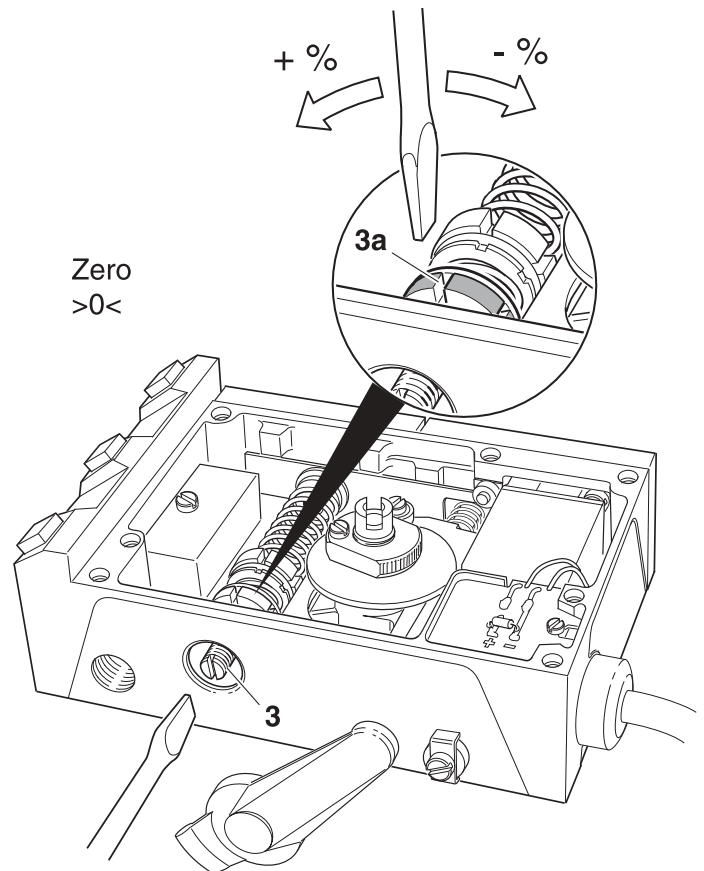

Range

4. Increase to 100% input signal.
5. Wait until the valve has adjusted.
6. Adjust the range by turning the red range nut(6).

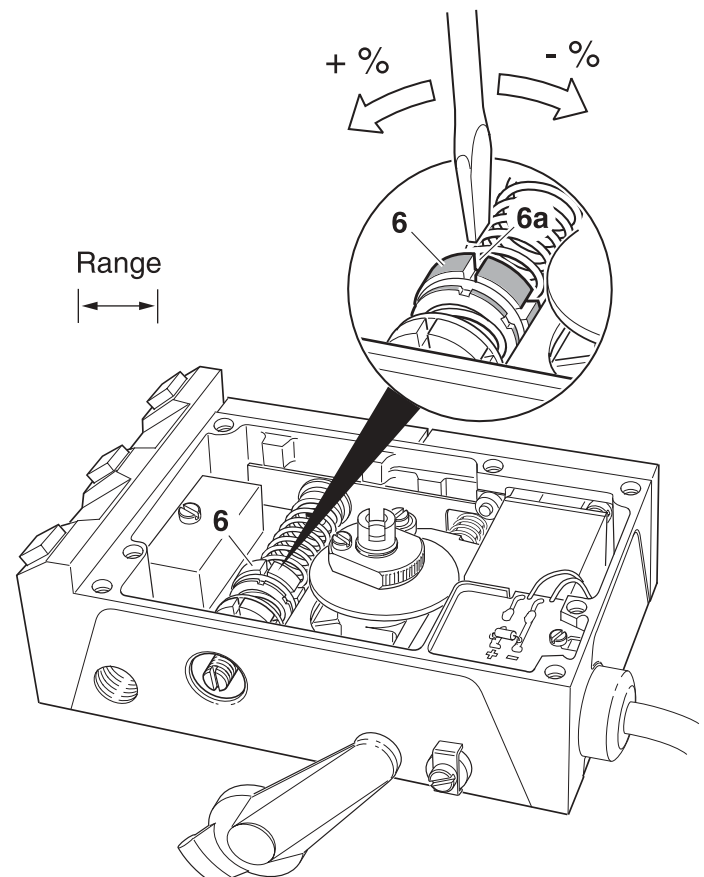

Check the zero position

Make fine adjustments if necessary.*

*With Split Range, where zeroing can be done by a signal other than 0%, the steps

1-6 must be repeated until the desired setting has been reached.



V100 Positioner

3. MAINTENANCE

3.1 Front cover and Indicator

Removing the front cover

Remove the four screws(1) and the front cover.

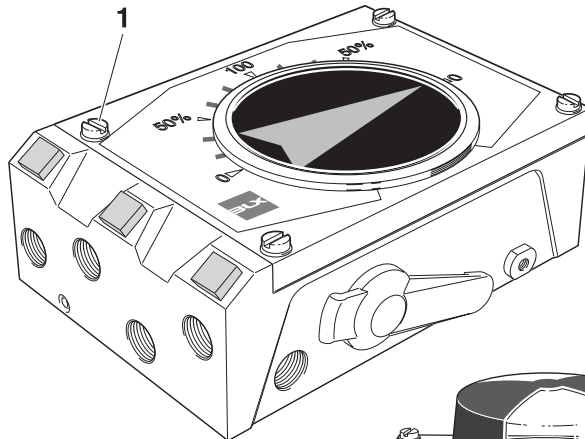

Changing the sealing in the front cover

Remove the indicator cover(2) by pressing from the backside.(see sketch)

Remove the rubber gasket(3) and replace with a new gasket.

Remove the O-ring(4) on the backside of the front cover and replace with a new O-ring.

Mount the indicator cover by installing its tap into the groove(5) of the front cover and lock it in place.

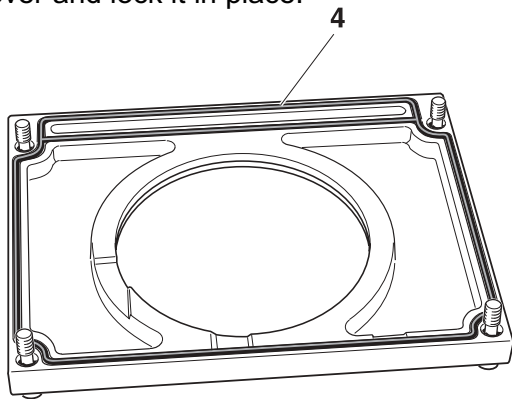
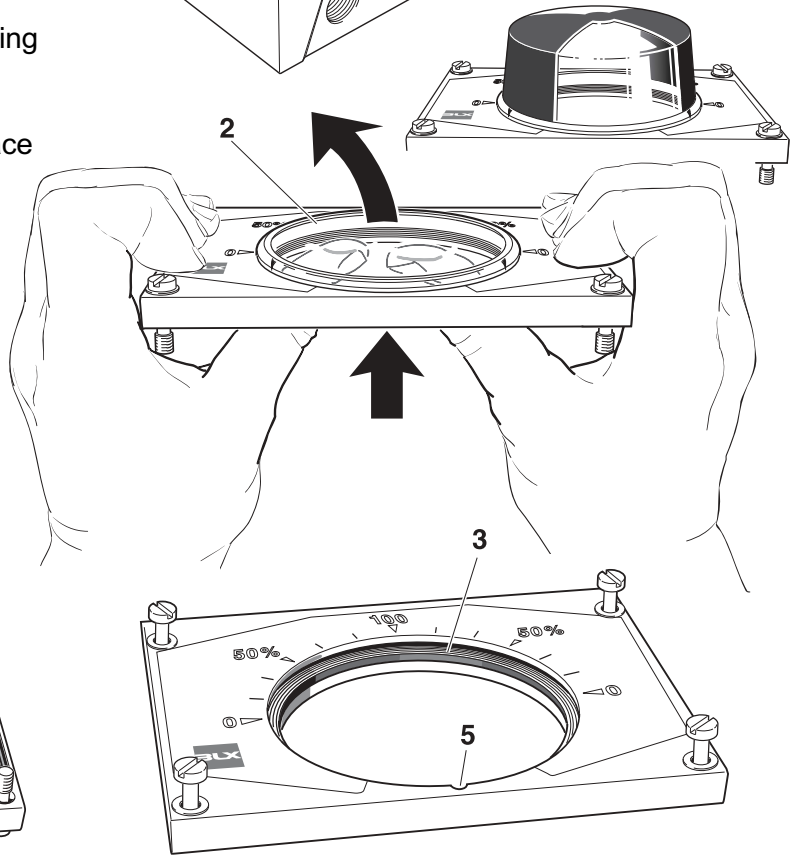

Removing the indicator

Pull the indicator(6) straight up.

Important Note!

Note the indicator's position so it can be remounted in the same position.

Mounting the indicator

Install the indicator in place over the drive shaft and press it straight down.

Turn the indicator to the proper display position.

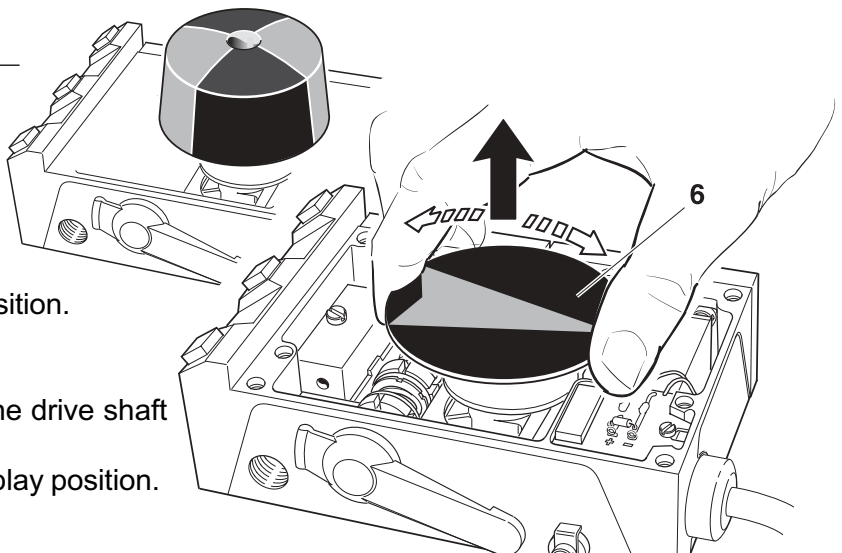



V100 Positioner

3.2 Pilot valve

Removal

Remove the front cover and indicator.
(see page 12)

Loosen the pilot retaining screw(1).

Lift the pilot valve(2) straight up.

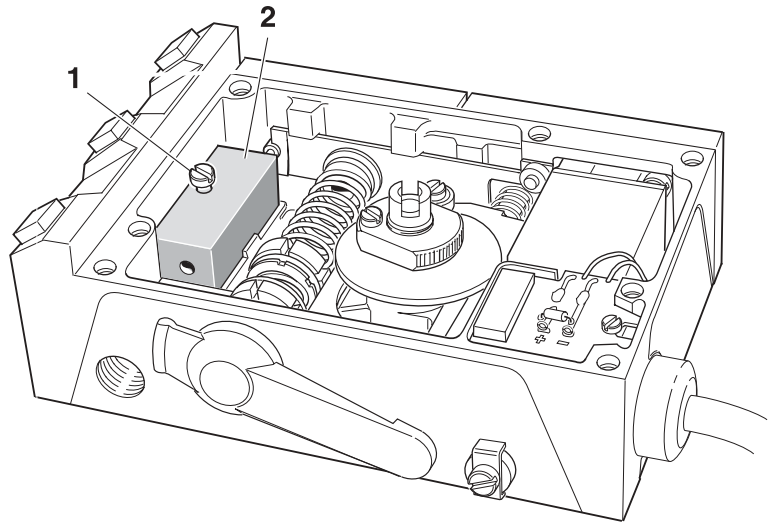

Cleaning

Remove the spool(3) from the valve housing.

Clean the parts with a soft cloth and pipe cleaner using alcohol, acetone or something similar.

Blow dry with clean, pressurized air.
Install the spool back in the valve housing.

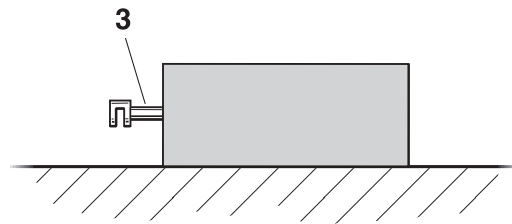

Check

Place the spool in its "working position".
(all four pistons inside the housing)
Slowly lift the pilot valve in one end.
The spool should start to glide before the angle exceeds 20°.(see sketch)

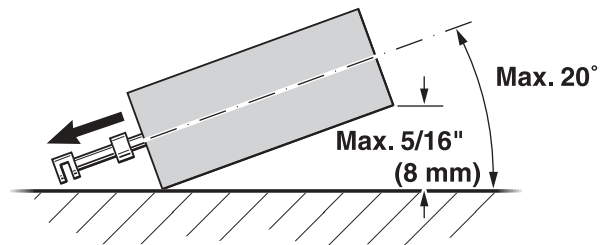

If any of the parts show signs of wear,
we recommend replacing with a new
pilot valve assembly.

The pilot valve's parts are matched to attain the best possible performance. Mixing of parts can result in high excessive bleed and/or poor function.

Install Pilot

Check the pilot valve's O-rings.

Be sure that the spool's "gap"(4) fits over the balance arm(5) and place the valve straight down into place.

Tighten the retaining screw(1).

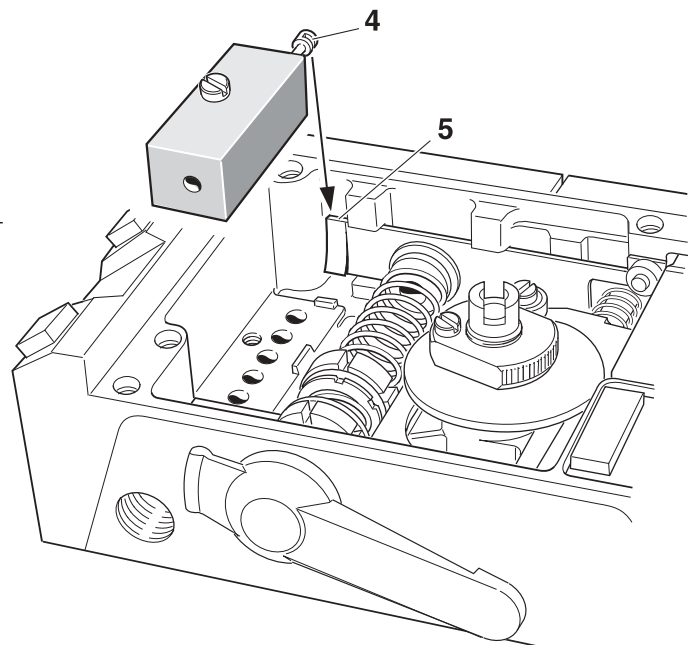

3.4 Filter

Changing the filter

1. Remove the front cover and indicator.
(See page 12)
2. Loosen the screw(1) and lift out the card.
3. Loosen the screws(3) and lift out the I/P-converter.
4. Loosen the screws(5) and remove the membrane cover(6).

Please Note!

Be sure that the O-ring in the cover(6) is not removed.

5. Cautiously remove the filter cap(7 & 8) with a sharp pointed object e.g. a pocket knife.
6. Remove the filter(9) from its rubber envelope.

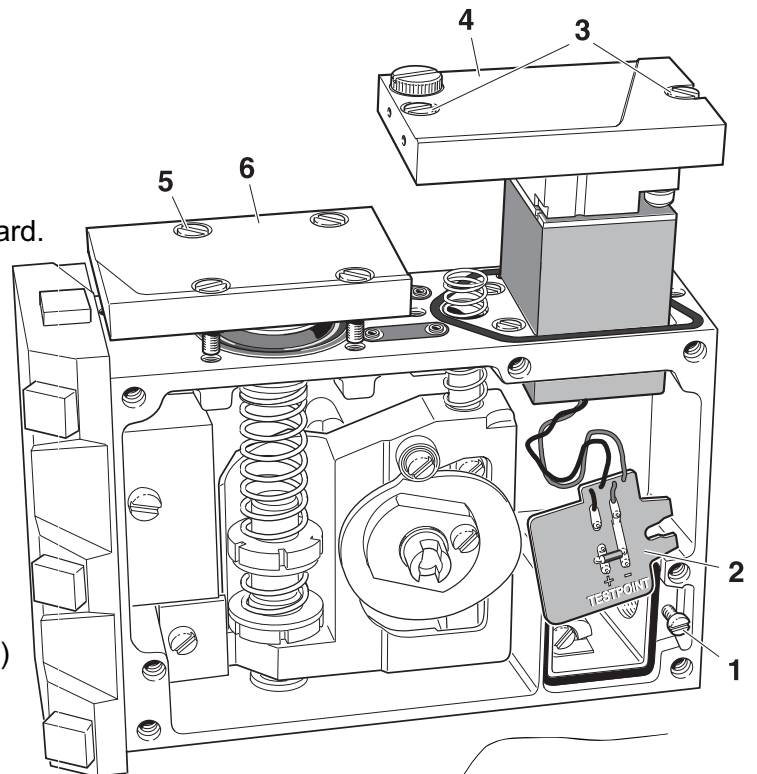

If the filter(9) shows traces of oil or water, check the water/ oil separator in the supply line.

Oil and water can cause functional problems in the I/P-converter.

7. Insert the new filter in the rubber envelope.
8. Press the filter caps(9) into the housing. To make installation in the housing easier, a small amount of grease or oil can be applied to the rubber.
9. Install the other parts in reverse order.

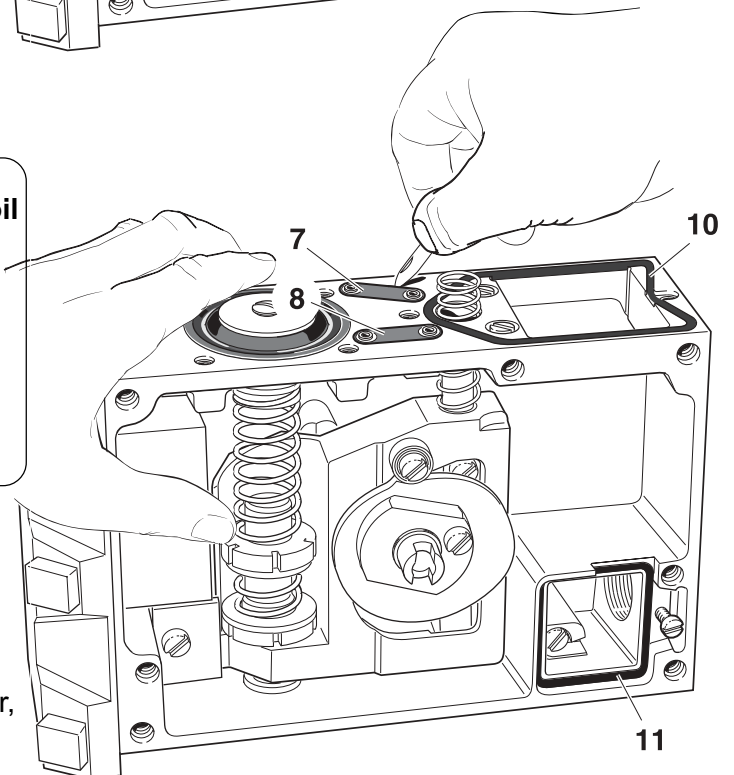

This side up

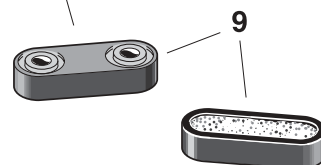

Please Note!

**Also check the seals.(10 & 11)
Replace if they are damaged.**



V100 Positioner

3.5 Membrane

Removal

Loosen the screws(1) and remove the membrane cover(2). Be cautious of the O-ring in the membrane cover.

Loosen the screw(3).

Remove the washer(4), membrane(5) and membrane piston(6).

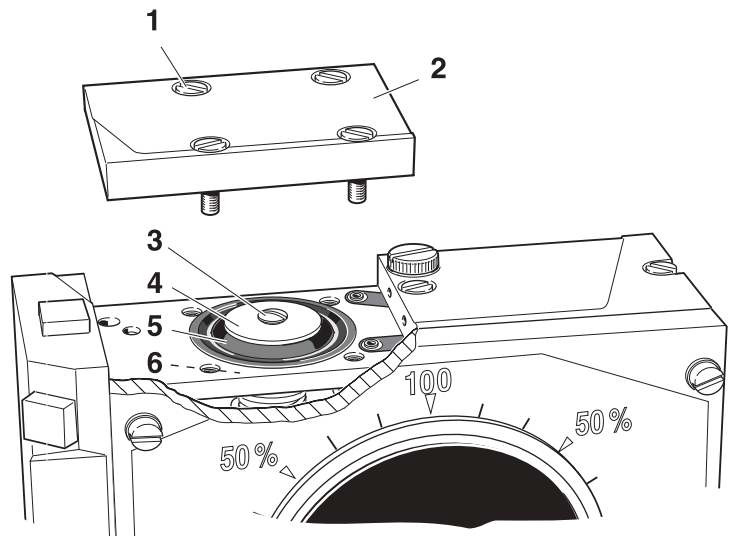

Mounting the membrane

Install the membrane piston(6) over the cylindrical dowel(7).

Place the membrane(5), with the bulge(8) hanging down towards the membrane piston(6).

Place the washer(4) on top, put the screw(3) in the hole and turn it tightly.

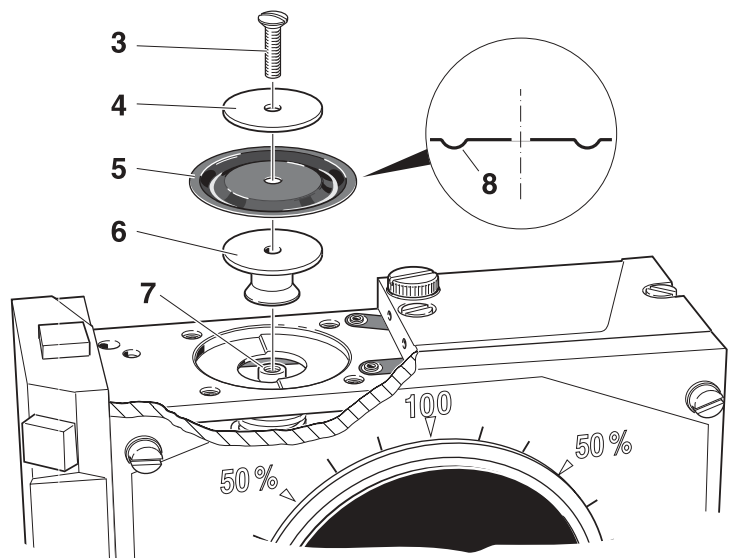

Mounting the membrane cover

Check that the O-ring(9) is not damaged. Install the membrane cover(2) and tighten the screws(1) crosswise.

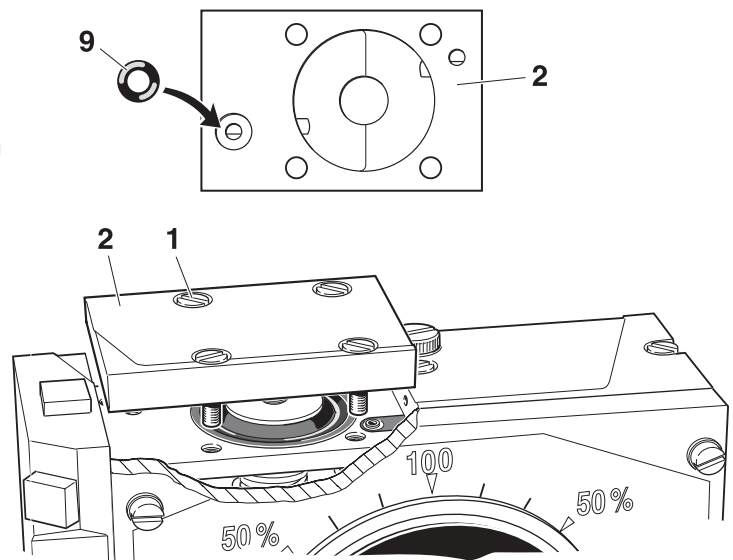



V100 Positioner

3.6 Feedback spring, changing

Removal

The feedback spring(1) can be removed by inserting a screwdriver between the upper spring coils and compressing it so that the upper spring socket is released from its seat.

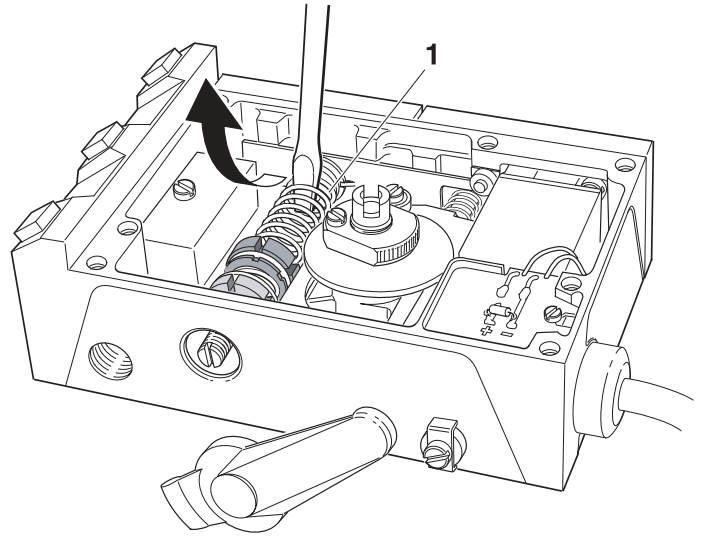

Mounting

Before the feedback spring is replaced, a basic adjustment must be performed. The A, B, and C gaps must be aligned.

The distance between the lower edge of the lower spring support and the upper edge of the red range nut must be less than 0.8" / 21mm before mounting.

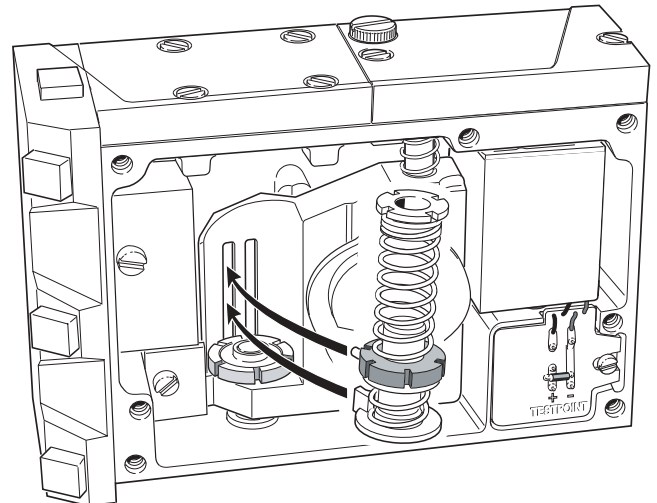
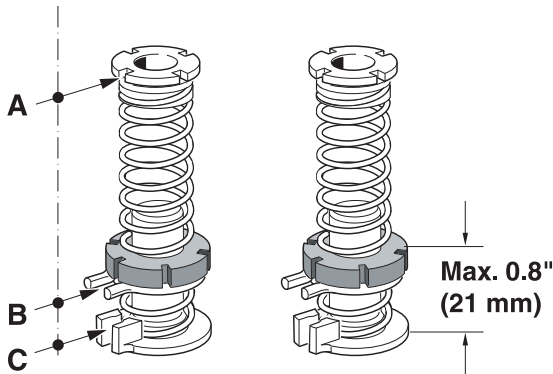

Fit the "gaps" B and C into the slots on the guided arm and at the same time install the lower spring support on the yellow zeroing wheel.

Compress the spring and flex it into the housing, securing the upper spring socket onto the stud on the balance arm.

Be sure that the upper spring socket and lower spring support lies flat with their respective contact surfaces and that the red range nut can be turned.

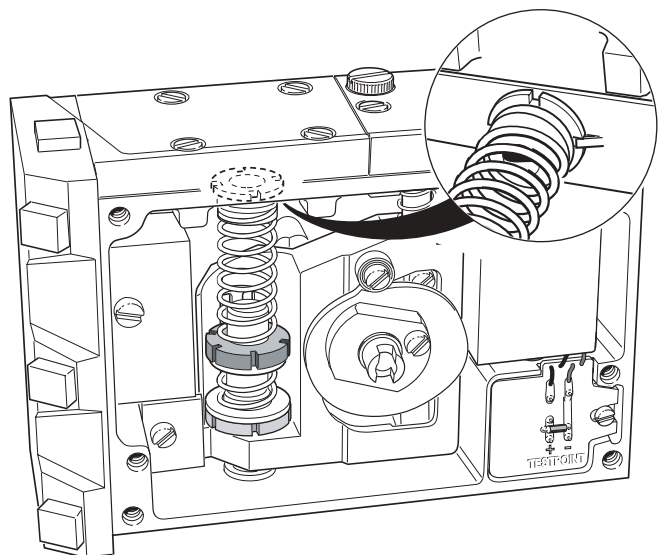



V100 Positioner

3.7 Feedback spring

Disassembling

- A. Remove the spring support(1) from the red range nut(3).
- B. Disassemble the spring support(1) and the spring(4).
- C. Hold the spring socket(5) and try to push the spring off the socket by pressing a screwdriver or similar against the end of the spring. (see sketch).

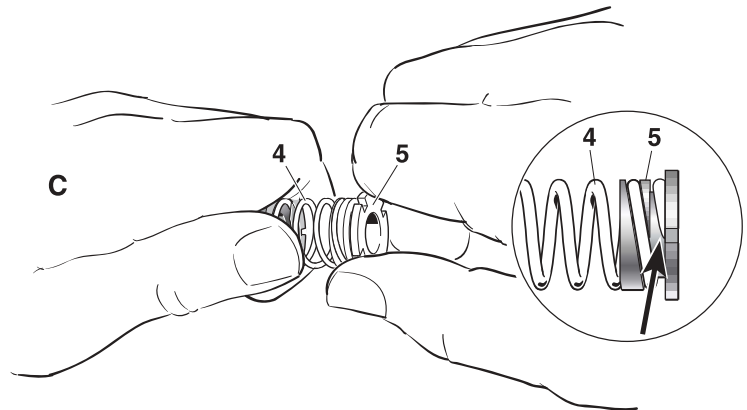
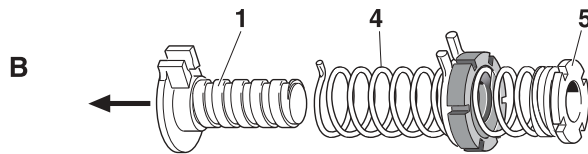
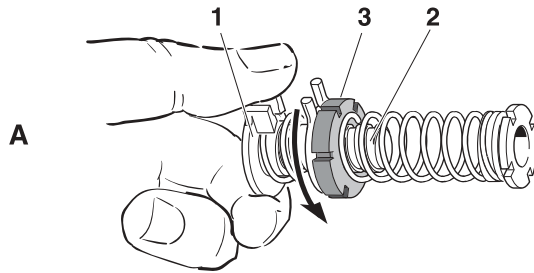

Please Note!
The spring is self-locking to the socket and may be very secure.

Reassembling

- D. Thread the range nut(3), with the friction spring(a) side first, onto the spring(4).
 - E. Screw the upper spring socket(5) into the spring(4). The spring is self-locking on the socket and should sit very tight.
- Turn the spring on to the socket as much as possible.

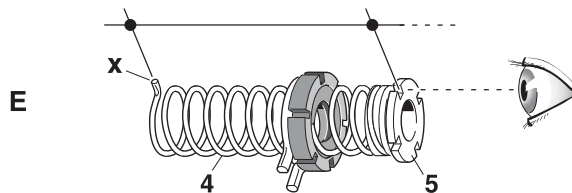
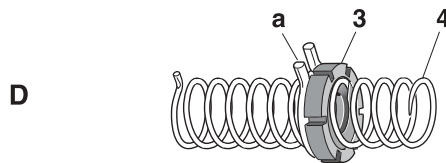

Note! One of the four grooves in the upper spring socket(5) must align with the dowel pin(x) on the spring.

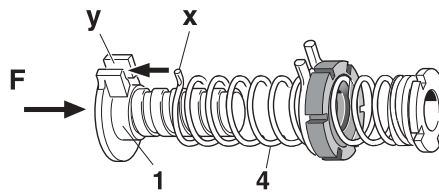

- F. Install the spring dowel(x) into the crotch(y) in the spring support(1).

- G. Thread the range nut(3) onto the screw(2). If this is difficult, it may help to compress the spring(4) slightly.

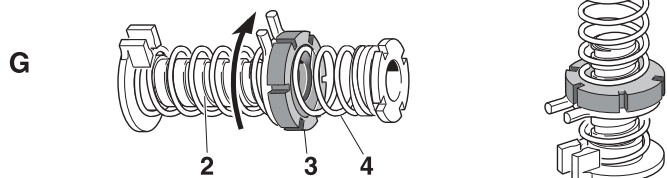



V100 Positioner

3.8 Balance arm

Removal

Before the balance arm can be removed, the front cover(1), I/P-converter or cover(2), membrane cover(3), membrane(4), feedback spring(5) and pilot valve(6) must all be removed.

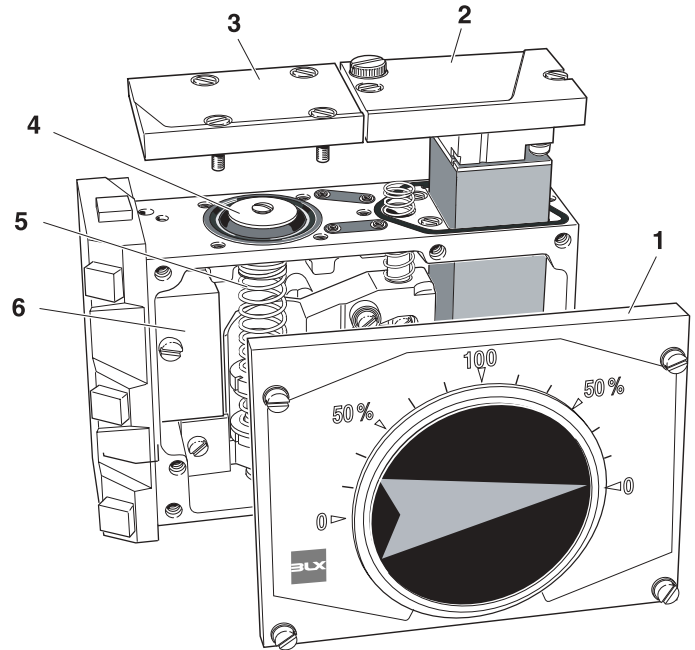

Loosen the screws(7) and remove the balance arm(8).

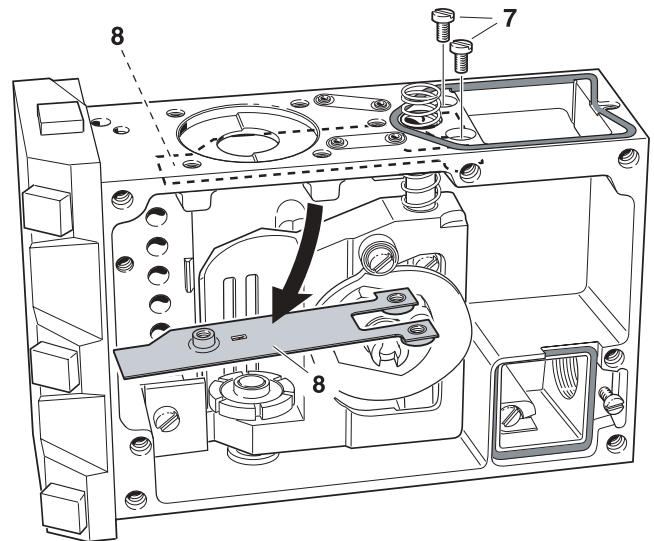

Mounting

Install the balance arm into the housing.

Center the dowel(9) with the hole in the housing.

Tighten the screws(7) and check the centering.

Install the remaining parts according to their respective instructions.

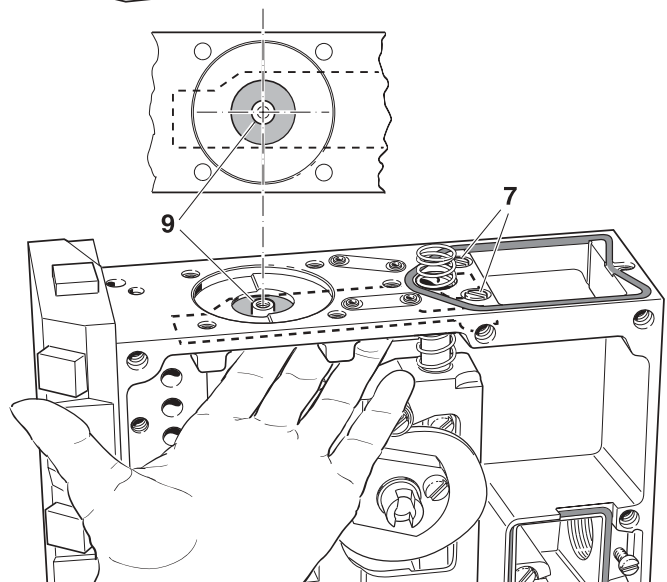

3.9 Guide arm, changing

Removal

Before the guide arm can be removed, the feedback spring (see page 17) and cam (see page 9) has to be removed.

Remove the stop washer(1).

Loosen the screws(2) and remove the arm(3) together with the guide pin(4) and spring(5).

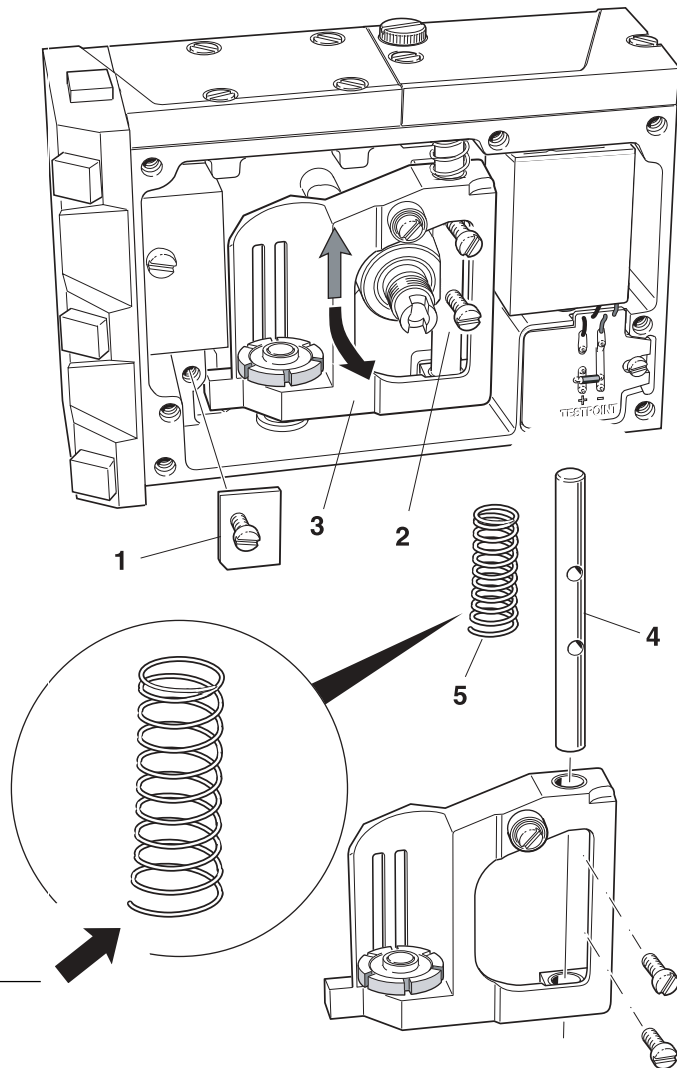

Mounting

Insert the guide pin(4) into the bearings of the arm.

Install the spring(5) on to the upper end of the guide pin with the larger end towards the arm.

Secure the guided arm with the guide pin into the V-block.

Tighten the two screws(2).

Apply a small amount of grease on the arm support's(6) sliding surfaces.

Mount the stop washer(1).

Make sure the arm moves freely.

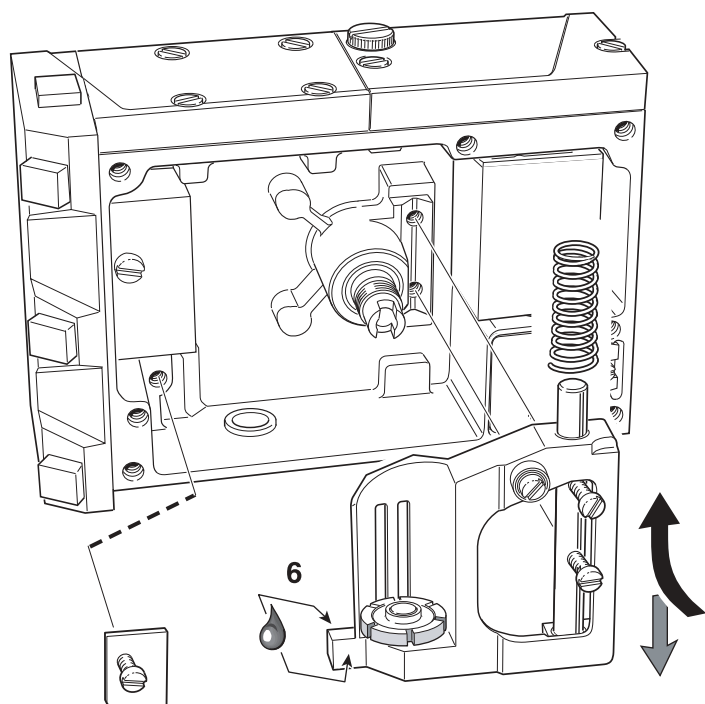



V100 Positioner

3.10 Guide arm, disassembly

Ball bearing, changing

Loosen the screw(1) and remove the ball bearing.

Mount the new ball bearing with Loctite in the M4-hole on the arm and tighten the screw securely.

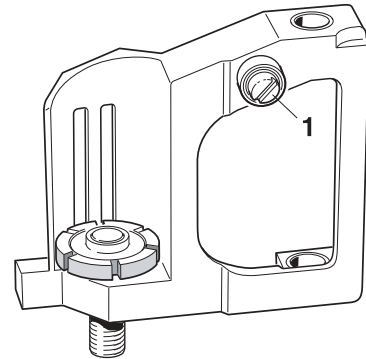

Zeroing screw, removal.

Loosen the socket set screw(2).

Remove the three spring washers(4) and the friction block(5).

The friction block may be difficult to remove and doesn't necessarily need to be removed to be able to unscrew the zeroing screw(3).

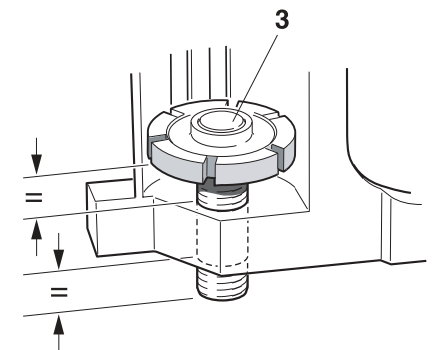
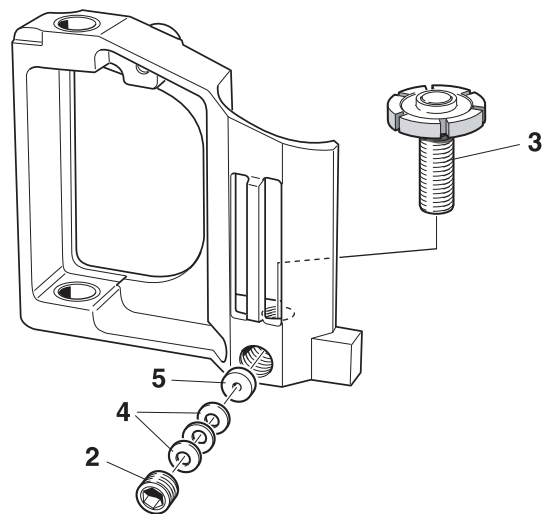

Mounting

Install the zeroing screw(3) to the middle position.

Mount the friction block(5) and the spring washers(4).

Screw in the socket set screw(2) tightly.

Loosen the screw 1/8 turn and check that the zeroing screw has proper turning friction.

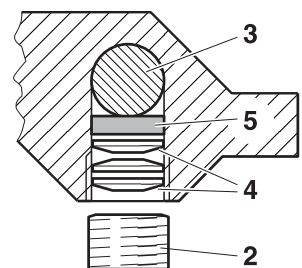
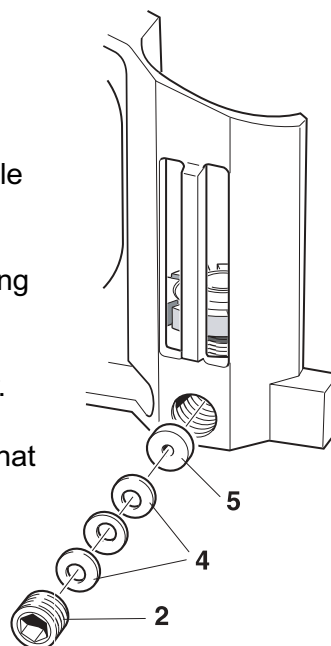



V100 Positioner

3.11 Drive shaft

Removal

Before the drive shaft can be loosened, the cam must be removed.

Remove the drive shaft(1) by hand from the inside. If necessary replace defective O-rings(2 & 3).

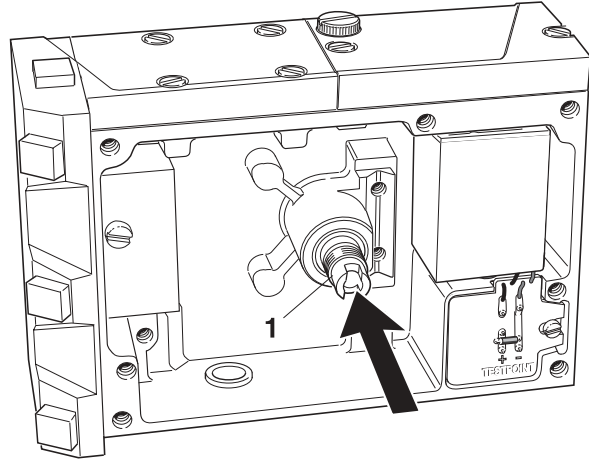

Mounting

Apply a small amount of oil to the drive shaft's surface and O-rings.

Install the drive shaft and press into place.

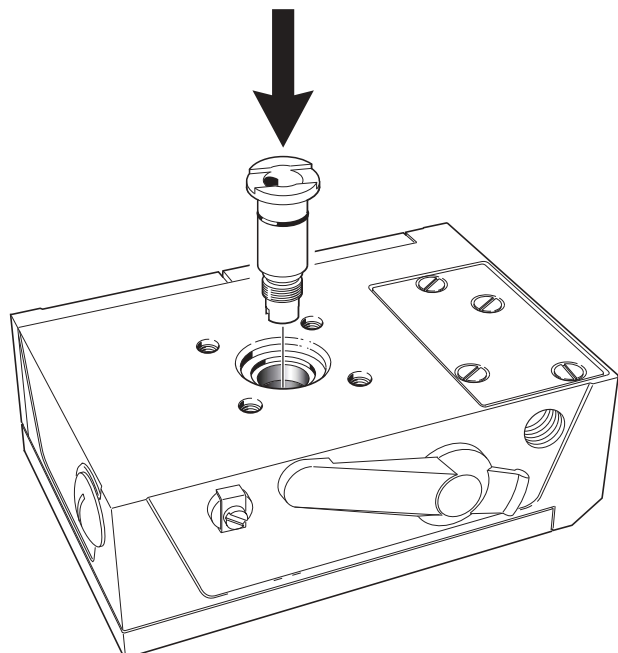
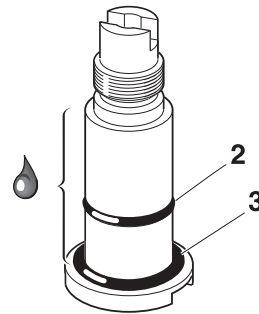



V100 Positioner

3.12 Drive

BLX offers a variety of drives(1), suitable for the most frequently used actuator types.

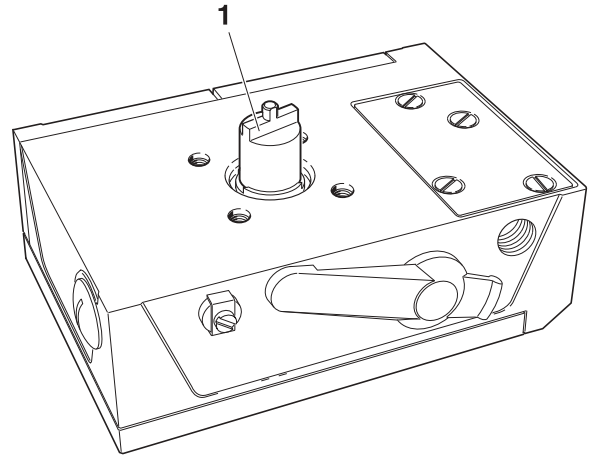

Removal

“Pop out” the drive by prying two screwdrivers, equally under the edges(2) of the drive, using the housing as fulcrum.

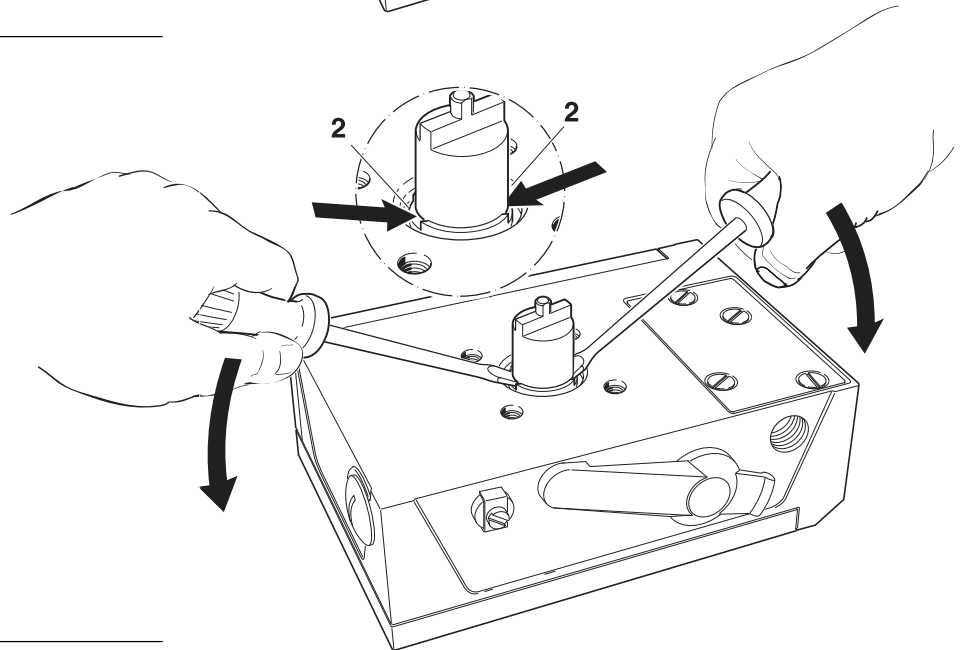

Mounting

Press the drive down into the drive shaft hole.

Turn the flats(3) into place and press down.

Check to see that the drive is set securely in place.

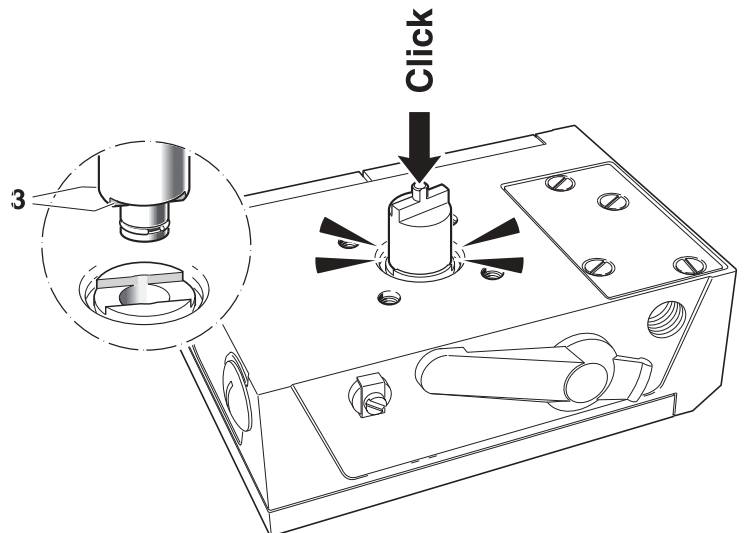



V100 Positioner

3.13 Safety valve

Removal

Loosen the screws(1).

Remove the tightening cover(2) and the gasket(3).

Lift out the safety valve(6).

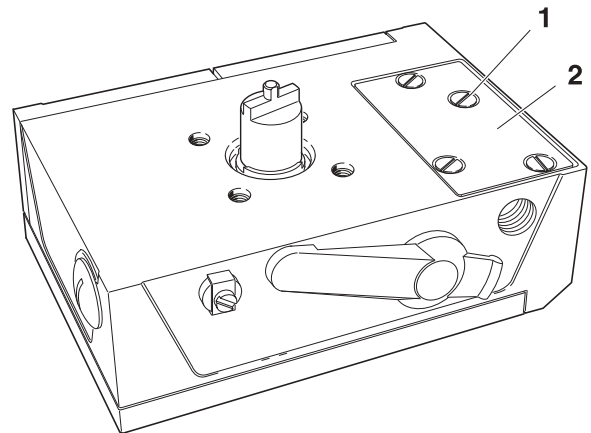

Safety valve, assembly

The safety valve is designed with a weak spring(4) and a rubber plug(5).

For proper functioning, the spring and the rubber plug need to be mounted together.

The spring turns firmly on the rubber plug's cylindrical section.

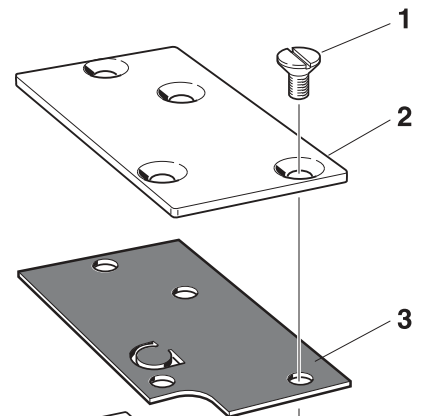
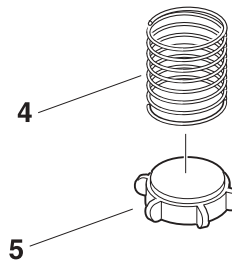

Mounting

Install the safety valve(6) with the rubber plug facing the housing.

Insert the gasket(3) and the tightening cover(2).

Mount the screws(1).

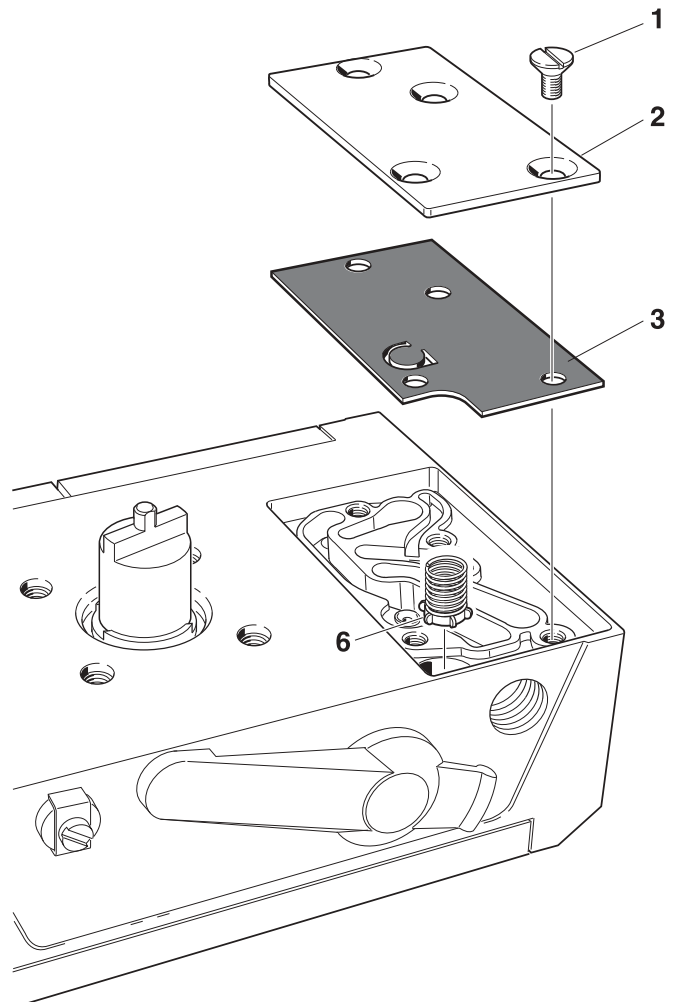



V100 Positioner

4. CONVERTING

4.1 Converting from V100P to V100E

1. Remove the front cover and indicator.
(see page 12)
2. Loosen the screws(1) and remove the cover(2).
3. Unscrew the protective plug from the I_E -connection(8).

Please Note!
Check the seals(3 & 4).
Replace if they are damaged.

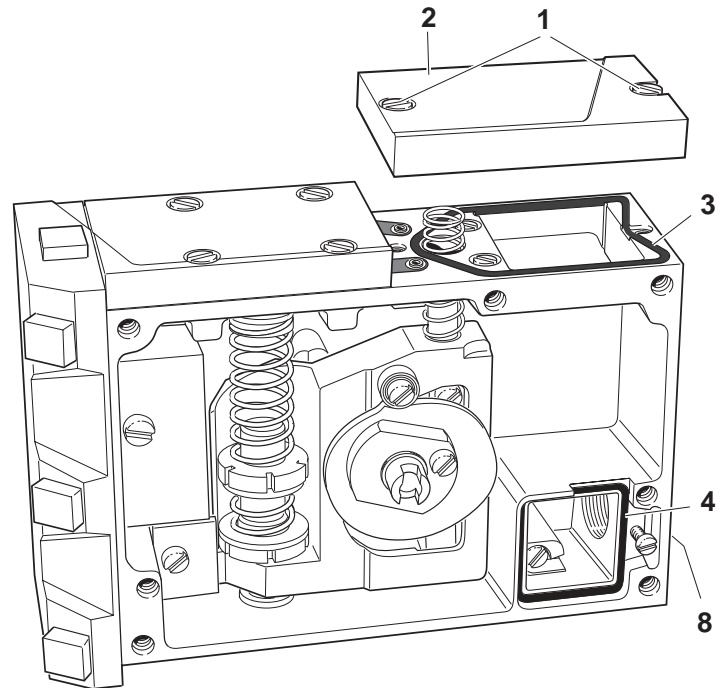

4. Insert the connection card(5) and the I/P-converter(6) through the square hole in the housing.
5. Secure the I/P-converter with the screws(7).
6. Install the connection card in its seat and secure with the locking screw(10).
7. Plug the port(9) marked I_P .
Threading requirements G 1/4" or 1/4" NPT is indicated by the markings on the housing.
8. Connect the control signal (see page 10).

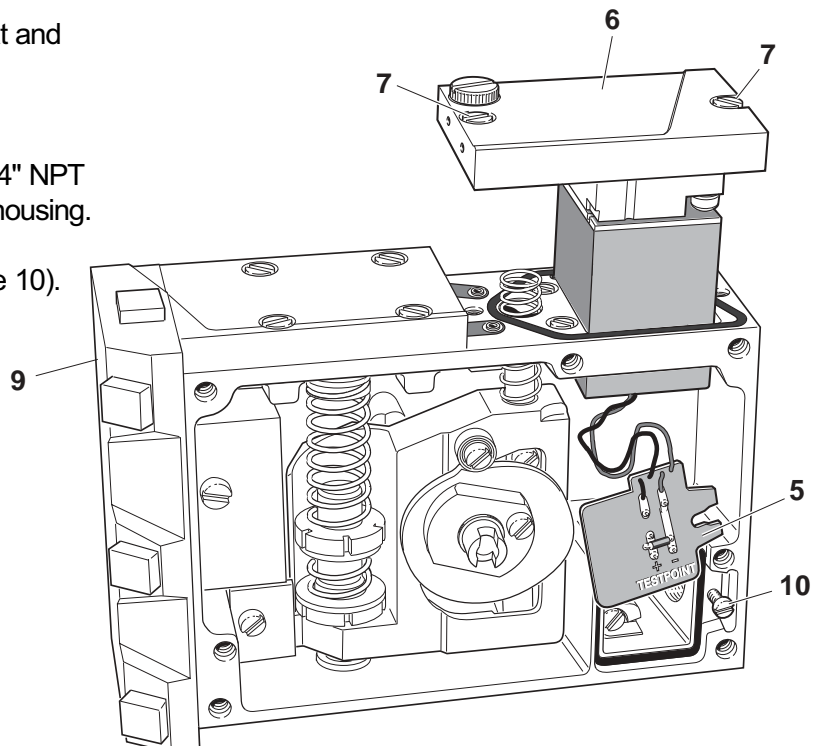



V100 Positioner

5. SPARE PARTS

5.1 Exploded drawing

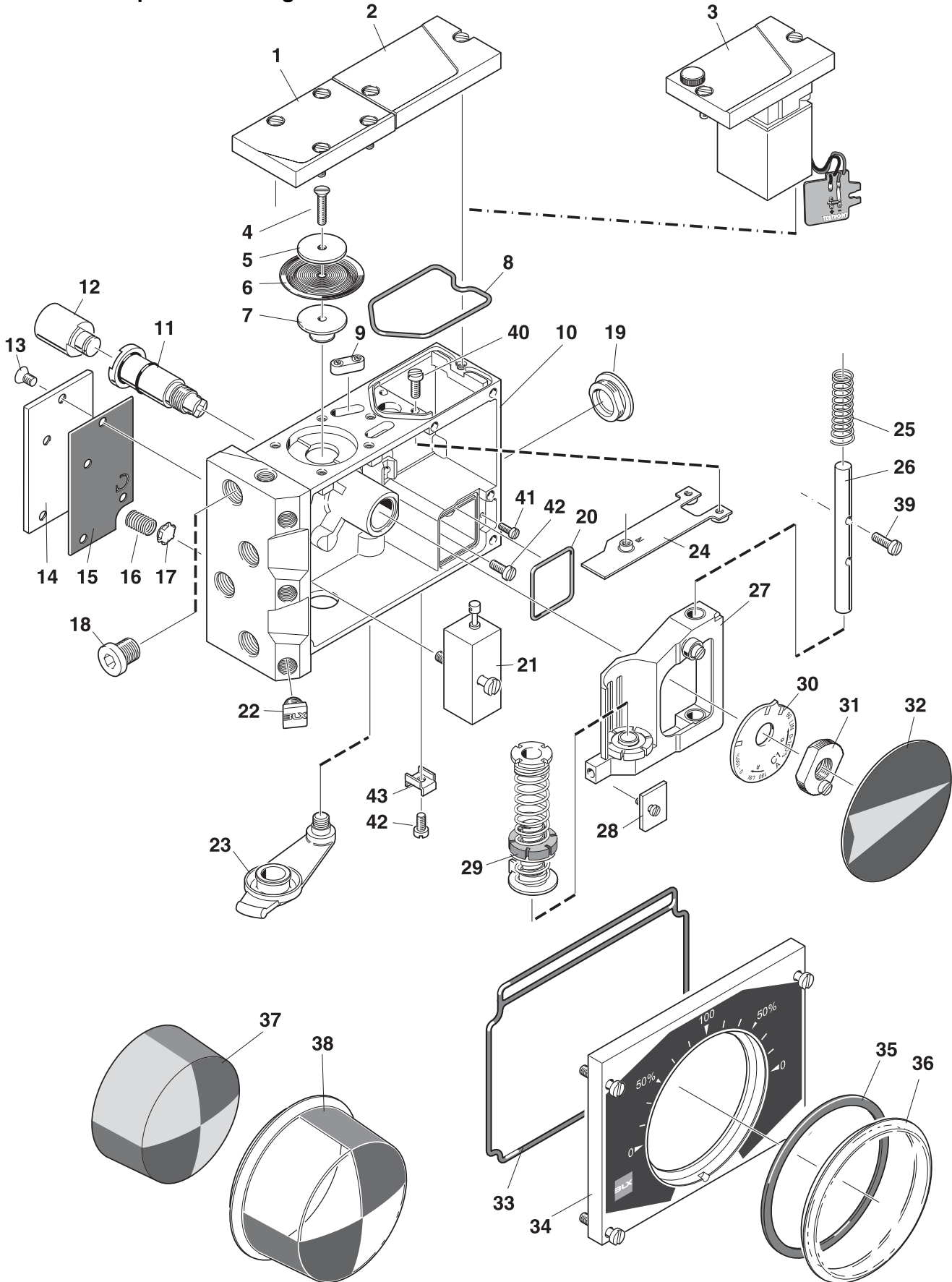



V100 Positioner

5.2 Spare parts list

Item	Description	Part no	Qty
1	Membrane cover	10066	1
	Screw MCS 5x14-5 SS		4
	- Mylar washer	10095	4
	- O-ring Ø 5x2 NBR		1
2	Cover plate	10061	1 (V100P only)
	- Screw MCS 5x14-5 SS		1
	- Screw MCS 5x12-5 SS		1
	- Mylar washer	10095	2
3	I/P-converter EA1	10160	1 (V100E only)
	- Restictor nozzle	10047	1
	- Connection card	10012	1
	- Screw MCS 5x14-5 SS		1
	- Screw MCS 5x12-5 SS		1
	- Mylar washer	10095	2
4	Screw MKFS 4x14 SS		1
5	Membrane washer	10019	1
6	Membrane	10035	1
7	Membrane piston	10018	1
8	O-ring Ø54x2.5 NBR		1
9	Filter cap	20030	2
	- Rubber channel nitrile	10008	1
	- Filter	10092	1
10	Housing		
	Bearing 15x8		2
11	Drive shaft	10022	1
	- O-ring Ø15x2 NBR		1
	- O-ring Ø12x1.5 NBR		1
12	Drive*		1
	- Spring circlip	10079	1
13	Screw MFS 5x8 SS		4
14	Tightening cover	10016	1
15	Gasket nitrile	10017	1
16	Safety valve spring	10021	1
17	Safety valve plug nitrile	10020	1
18	Plug 1/4" S2610-1/4		1
19	Blind plug NPT 1/2"	10026	1
	Blind plug M20x1.5	20032	1
	Blind plug PG 13.5	20033	1
	- O-ring Ø 18.5x1.5 NBR		1
20	O-ring Ø 34x2 NBR		1
21	Pilot valve W1	10039	1
	Pilot valve W2	10071	1
	Pilot valve W3 (Standard)	10090	1
	- Screw MCS 5x25-5 SS		1
	- O-ring Ø 5x1.5 NBR **		5
	- Valve gasket	10093	1
22	Gauge plug	10048	4
23	Zero plug nitrile	10005	1
24	Balance arm	10013	1
25	Retainer spring	10075	1
26	Guide pin	10015	1
27	Guided arm complete	10161	1
	- Ball bearing		1
	- Zero screw	10091	1
	- Screw MCS 4x10 SS		1
	- Bearing 8x8		2
28	Stop washer	10014	1
	- Screw MCS 4x8-4 SS		1
29	Feedback spring assembly	10159	1
30	Cam C1 (Std) *	10024	1
31	Cam nut	10023	1
	- Screw MCS 4x8 SS		1
32	Indicator Arrow	10064	1
	- Circlip SGA 15 SS		1
33	O-ring front cover nitrile	10072	1
34	Front cover assembly	20031	1
	- O-ring front cover nitrile	10072	1
	- Front label 0-90-0° (Standard)*	20006	1
	- Screw MCS 5x20-5 SS		4
	- Mylar washer	10095	2
35	Indicator gasket nitrile	10036	1
36	Indicator cover flat	10000	1
37	Indicator, raised	10063	1
	- Circlip SGA 15 SS		1
38	Indicator cover Raised	10043	1
39	Screw MCS 4x16 SS		2
40	Screw MCS 4x10 SS		2
41	Screw MCS 3x10 SS		1
42	Screw MSCS 4x8 SS		2
43	Grounding clamp	10067	1

*Cams with other ranges, Front labels with other scale readings and Drive's suitable for the most frequently used actuator types, are available.

**Only Spool valves marked: 10039-R0-WA1, 10071-R0-WA2, 10071-R1-WA2, 10090-R0-WA3 and 10090-R1-WA3



V100 Positioner

6. TECHNICAL INFO

6.1 Specifications

	V100P	V100E
Input range:	3-15 PSI (20-100kPa)	4-20 mA (Ri<250ohms)
Supply pressure:	<145 PSI (<1MPa)	21.8-145 PSI (0.15-1MPa)
Linearity error:	<0.7% f.s	<1.0% f.s
Hysteresis:	<0.4% f.s	<0.6% f.s
Repeatability:	<0.3% f.s	<0.5% f.s
Pressure Gain:		
@87 PSI (600kPa)	$750 \frac{P_{out}}{P_{in}}$	$750 \frac{P_{out}}{P_{in}}$
acc. to ISA S75.13	$49 \% \frac{P_{out}}{P_{in}}$	$49 \% \frac{P_{out}}{P_{in}}$
Air Capacity:	SCFM (SLPM)	SCFM (SLPM)
@29 PSI (200kPa)	9.5 (270)	9.5 (270)
@87 PSI (600kPa)	28.3 (800)	28.3 (800)
@145 PSI (1MPa)	47.1 (1350)	47.1 (1350)
Bleed Rate:	SCFM (SLPM)	SCFM (SLPM)
@29 PSI (200kPa)	0.18 (5)	0.2 (5.7)
@87 PSI (600kPa)	0.53 (15)	0.6 (17.0)
@145 PSI (1MPa)	0.88 (25)	1.0 (28.3)
Weight:	3.5 lbs (1.6kg)	3.8 lbs (1.7kg)
Weight with gauges:	4.0 lbs (1.8kg)	4.2 lbs (1.9kg)
Temp range:	-40° to +185° Fahrenheit -40° to +85° Celsius	
Air connectors:	1/4" NPT (optional G threads)	
Gauges:	1/8" NPT (optional G threads)	
Cable entry:	1/2" NPT (optional M20x1.5 or PG 13.5)	
Ingress & corrosion protection:	NEMA 4X and IP66	
Coating:	Powder Polyester	
Options:	Feedback Spring for 6-30 PSI (40-200kPa) input signal. Gauges.	
Pilot Valves:		
W1	Low Gain-Medium Flow-Low Bleed for better stability and lower bleed. Pressure gain @87 PSI =300 Bleeds approx. 33% < than W3 Air capacity =10% < W3 (above chart)	
W2	High Gain-High Flow-High Bleed For faster response and better accuracy. Pressure gain @87 PSI >1000 Bleeds approx. 33% > than W3 Air capacity = W3 (above chart)	
W3	Medium Gain-High Flow-Medium Bleed For "average" capacity and bleed Standard Pilot Assembly Specifications shown in above chart	



V100 Positioner

6.2 Dimensions

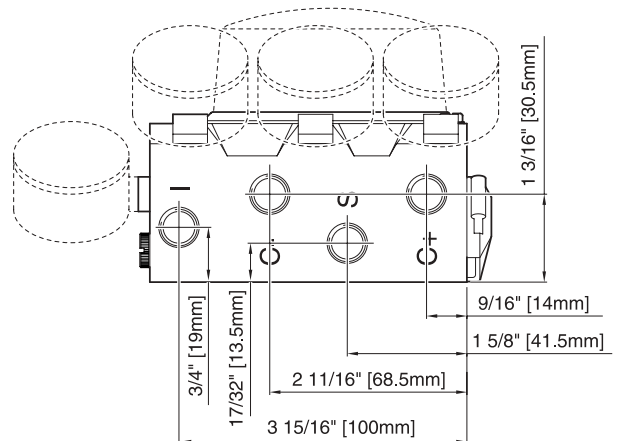
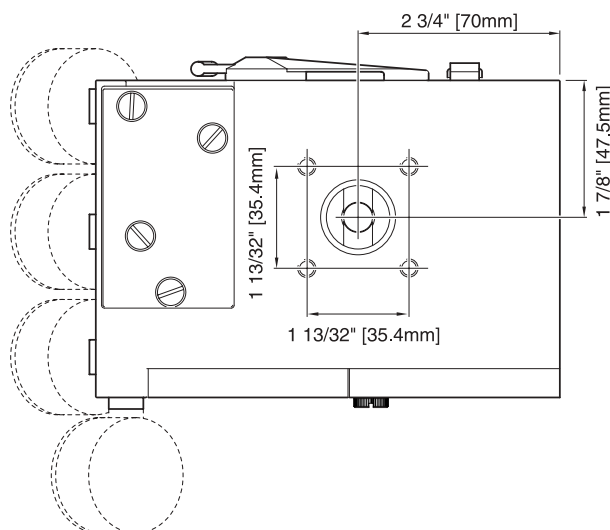
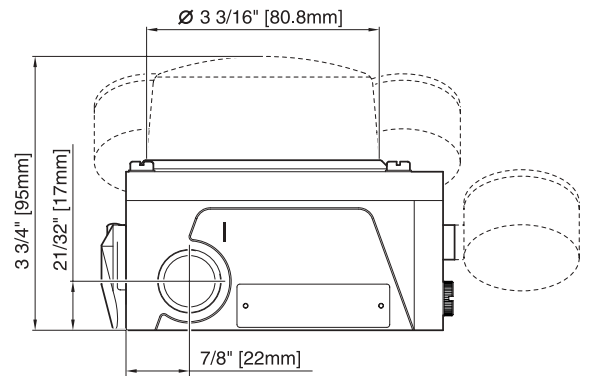
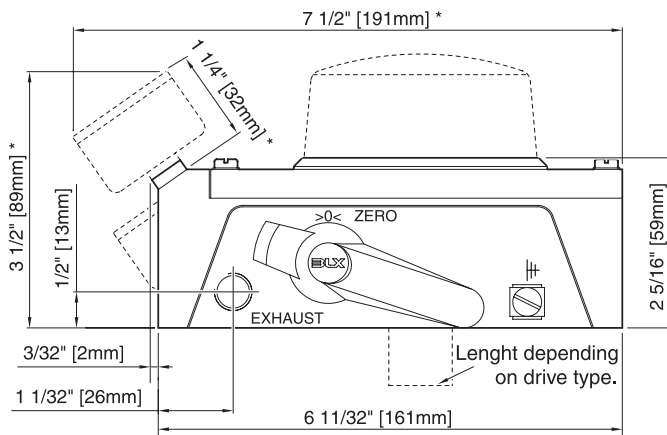
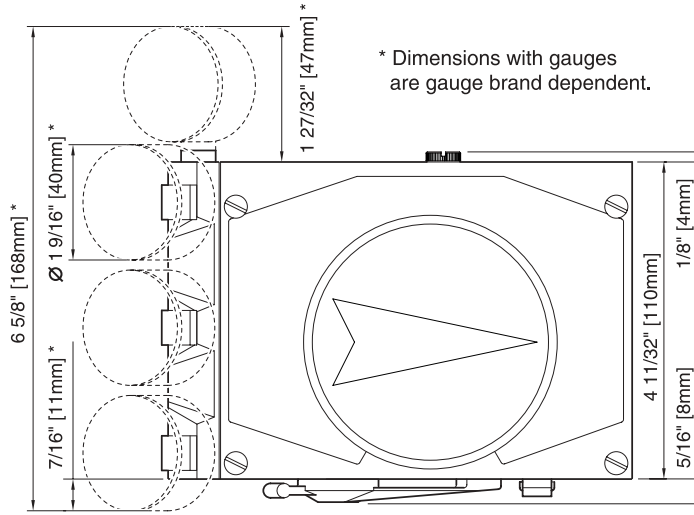



www.vacaccessories.com

Valve Accessories & Controls, Inc.

200 Jade Park

Chelsea, AL 35043

TEL: (11) 205-678-0507 • FAX: (11) 205-678-0510

vacaccessories.com