

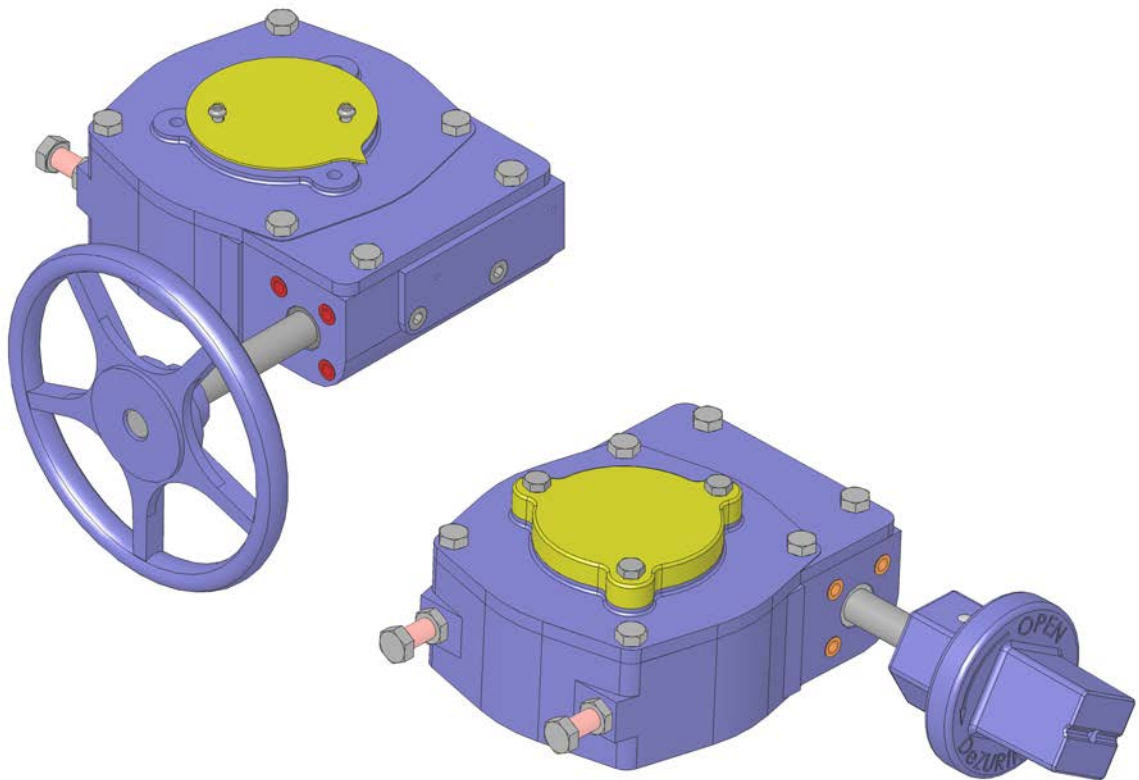

**DeZURIK G-SERIES (6B/12A)
MANUAL ACTUATOR
USED ON BAW BUTTERFLY VALVES**



Instruction D10505
January 2018

DeZURIK

G-Series (6B/12A) Manual Actuator used on BAW Butterfly Valves

Instructions

These instructions provide information about G-Series Manual Actuators. They are for use by personnel who are responsible for installation, operation and maintenance of G-Series Manual Actuators.

Safety Messages

All safety messages in the instructions are flagged with an exclamation symbol and the word Caution, Warning or Danger. These messages indicate procedures that must be followed exactly to avoid equipment damage, personal injury or death.

Safety label(s) on the product indicate hazards that can cause equipment damage, personal injury or death. If a safety label becomes difficult to see or read, or if a label has been removed, please contact DeZURIK for replacement label(s).



WARNING!

Personnel involved in the installation or maintenance of valves should be constantly alert to potential emission of pipeline material and take appropriate safety precautions. Always wear suitable protection when dealing with hazardous pipeline materials. Handle valves, which have been removed from service with suitable protection for any potential pipeline material in the valve.

Inspection

Your G-Series Manual Actuator has been packaged to provide protection during shipment; however, it can be damaged in transport. Carefully inspect the unit for damage upon arrival and file a claim with the carrier if damage is apparent.

Parts

Recommended spare parts are listed on the assembly drawing. These parts should be stocked to minimize downtime.

Order parts from your DeZURIK sales representative, or directly from DeZURIK. When ordering parts, please include the 7-digit part number and 4-digit revision number (example: **9999999R000**) and serial number located on the data plate attached to the valve assembly. Also include the part name, the assembly drawing number, the balloon number and the quantity stated on the assembly drawing.

DeZURIK Service

DeZURIK service personnel are available to install, maintain and repair all DeZURIK products. DeZURIK also offers customized training programs and consultation services.

For more information, contact your local DeZURIK sales representative or visit our website at www.dezurik.com.

Table of Contents

Instructions	2
Safety Messages	2
Inspection	2
Parts	2
DeZURIK Service.....	2
Table of Contents.....	3
Description.....	4
Operation	4
Tools Required.....	4
Lubrication	4
Parts Identification	5
Adjusting Position Stops	6
<i>To adjust the closed position stop</i>	<i>6</i>
<i>To adjust the open position stop.....</i>	<i>6</i>
Removing Actuator from Valve.....	8
<i>G_-6B Actuator on 3 – 12 Inch Valves (Figure 5).....</i>	<i>10</i>
<i>G_-6B Actuator on 14 – 20 Inch Valves (Figure 5).....</i>	<i>10</i>
<i>G_-12A Actuator on 20 – 30 Inch Valves (Figure 6).....</i>	<i>10</i>
Installing Actuator on Valve.....	11
<i>G_-6B Actuator on 3 – 12 Inch Valves</i>	<i>11</i>
<i>G_-6B Actuator on 14 – 20 Inch Valves</i>	<i>11</i>
<i>G_-12A Actuator on 20 – 30 Inch Valves</i>	<i>12</i>
Actuator Disassembly and Assembly	13
<i>Actuator Disassembly:</i>	<i>13</i>
<i>Actuator Assembly:.....</i>	<i>14</i>
Replace Handwheel or Nut with Chainwheel Operator.....	17
<i>GS-6B-CW_ (8 and 12 Inch Chainwheels).....</i>	<i>17</i>
<i>GS-6B-CW_ (20 and 24 Inch Chainwheels).....</i>	<i>18</i>
<i>GS-12A-CW_.....</i>	<i>19</i>
Changing Mounting Positions.....	20
Troubleshooting	20

DeZURIK

G-Series (6B/12A) Manual Actuator used on BAW Butterfly Valves

Description

The G-Series Manual Actuator is designed to operate a BAW Butterfly valve. External adjustable stops limit actuator stroke for both the open and closed valve positions. This actuator is available in two sizes: Size 6B and Size 12A. See Figure 1 to identify which unit you have.

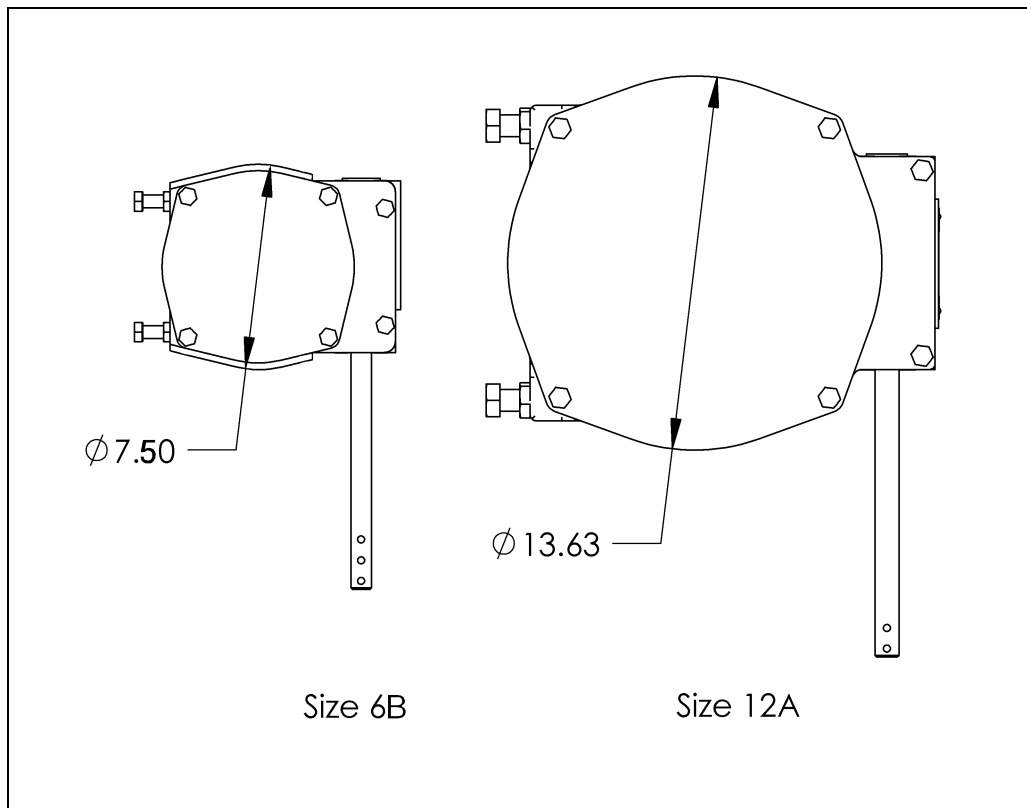

Figure 1 - Actuator Identification

Operation

Rotating the operator (handwheel, chainwheel or 2" wrenching square) clockwise closes the valve. Counterclockwise rotation of the operator opens the valve. To actuate the valve from full open to full closed (or vice-versa), the Size 6B requires 13 revolutions and the Size 12A requires 19 revolutions of the operator.

Tools Required

This actuator is assembled using metric fasteners. To service this unit, you should have a full set of combination or ratchet wrenches, Allen wrenches, flat tipped screwdrivers, a 1/4" pin punch and a dead blow hammer.

Lubrication

The G-Series manual Actuator has been lubricated at the factory and requires no routine maintenance lubrication. If the actuator requires disassembly, see the ACTUATOR DISASSEMBLY AND ASSEMBLY section in this instruction for disassembly, lubrication and assembly procedures.

**G-Series (6B/12A) Manual Actuator
used on BAW Butterfly Valves**

Parts Identification

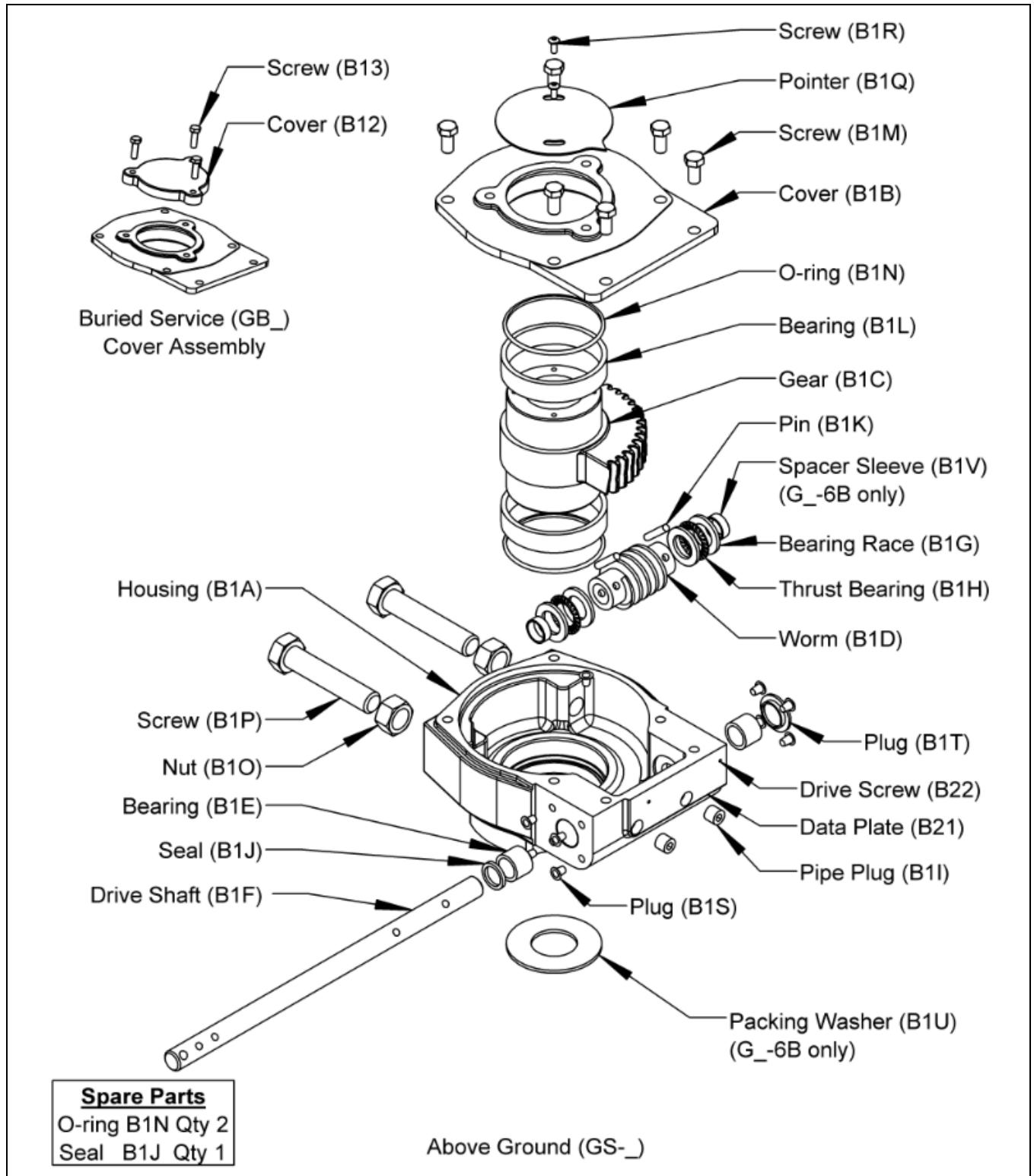

Figure 2— Actuator Parts Identification

Adjusting Position Stops

The open and closed position stops prevent the valve disc from rotating beyond the optimum open and shutoff positions.

If the actuator is factory-mounted on the valve, the stops are preset, and do not require further adjustment. If the actuator is not factory mounted on the valve, or if the actuator has been removed, the stops will require adjustment as described below; also refer to the Valve Instructions for specific closed-position requirements for the valve.

To adjust the closed position stop

(see Figure 4 for stop identification)



WARNING!

Adjusting stops with flow in the pipeline can allow the valve to close causing personal injury and damaging the flow system.

Shut down the flow and relieve pipeline pressure before making stop adjustments.

1. Discontinue flow and relieve pipeline pressure.
2. Loosen the nut on the closed position screw, and back out the screw about two turns.
3. Close the valve.
4. Turn the closed position screw clockwise until resistance is felt from the screw contacting the gear (B1C).
5. Prevent the screw from turning and tighten the nut against housing (B1A).
6. Pipeline flow may now be restored.

To adjust the open position stop

(see Figure 4 for stop identification)



WARNING!

Adjusting stops with flow in the pipeline can allow the valve to close causing personal injury and damaging the flow system.

Shut down the flow and relieve pipeline pressure before making stop adjustments.

1. Discontinue flow and relieve pipeline pressure.
2. To visually determine when the valve is in the open position:
Above Ground Service (GS_) actuator - Remove the screws (B1R) and pointer (B1Q).
Buried Service (GB_) actuator - Remove the screws (B13) and cover (B12).
3. Loosen the nut on the open position screw, and back out the screw about two turns.

G-Series (6B/12A) Manual Actuator used on BAW Butterfly Valves

Adjusting Position Stops (Continued)

- Turn the handwheel, chainwheel or 2" wrenching square operator so the drive key/plug alignment is parallel to the valve flanges. See Figure 3 for valve open position.

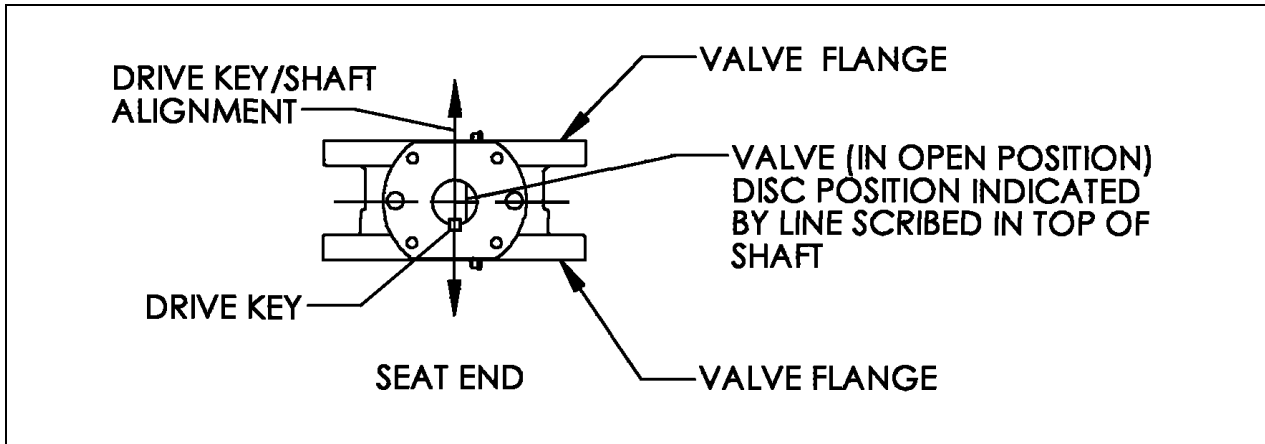

Figure 3 – Valve Open Position

- Turn the open position screw clockwise until resistance is felt from the screw contacting the gear (B1C).
- Buried Service (GB_) actuator:** Apply 2 wraps of string packing (1013701) to the actuator stop screw threads between jam nut and actuator.
- Prevent the screw from turning, and tighten the nut (B10) against housing (B1A).
- Above Ground Service (GS_) actuator:** Replace the pointer (B1Q) so it is pointing at the OPEN mark on the cover (B1B) and tighten screws (B1R).

Buried Service (GB_) actuator: Remove old sealant from cover (B12) and cover (B1B) mating mounting surfaces. Apply a bead of silicone sealant DOW RTV-732 (1055515) or similar to the cover (B12) and cover (B1B) mating surfaces. Fasten the cover (B12) to cover (B1B) with screws (B13).

- Pipeline flow may now be restored.

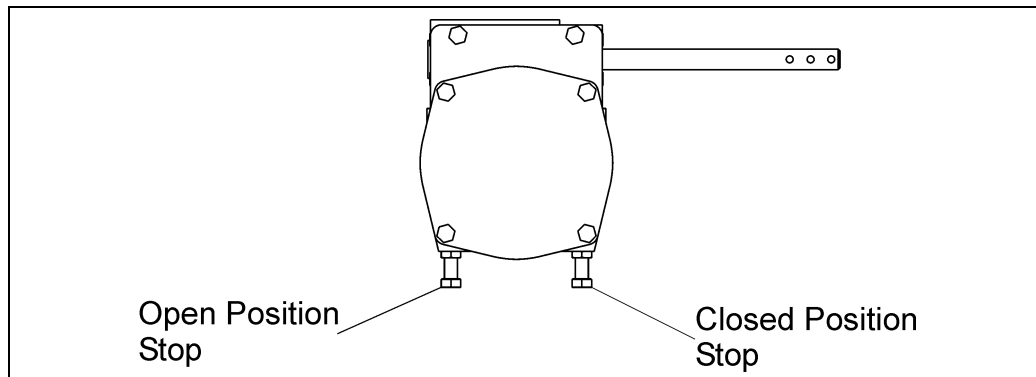
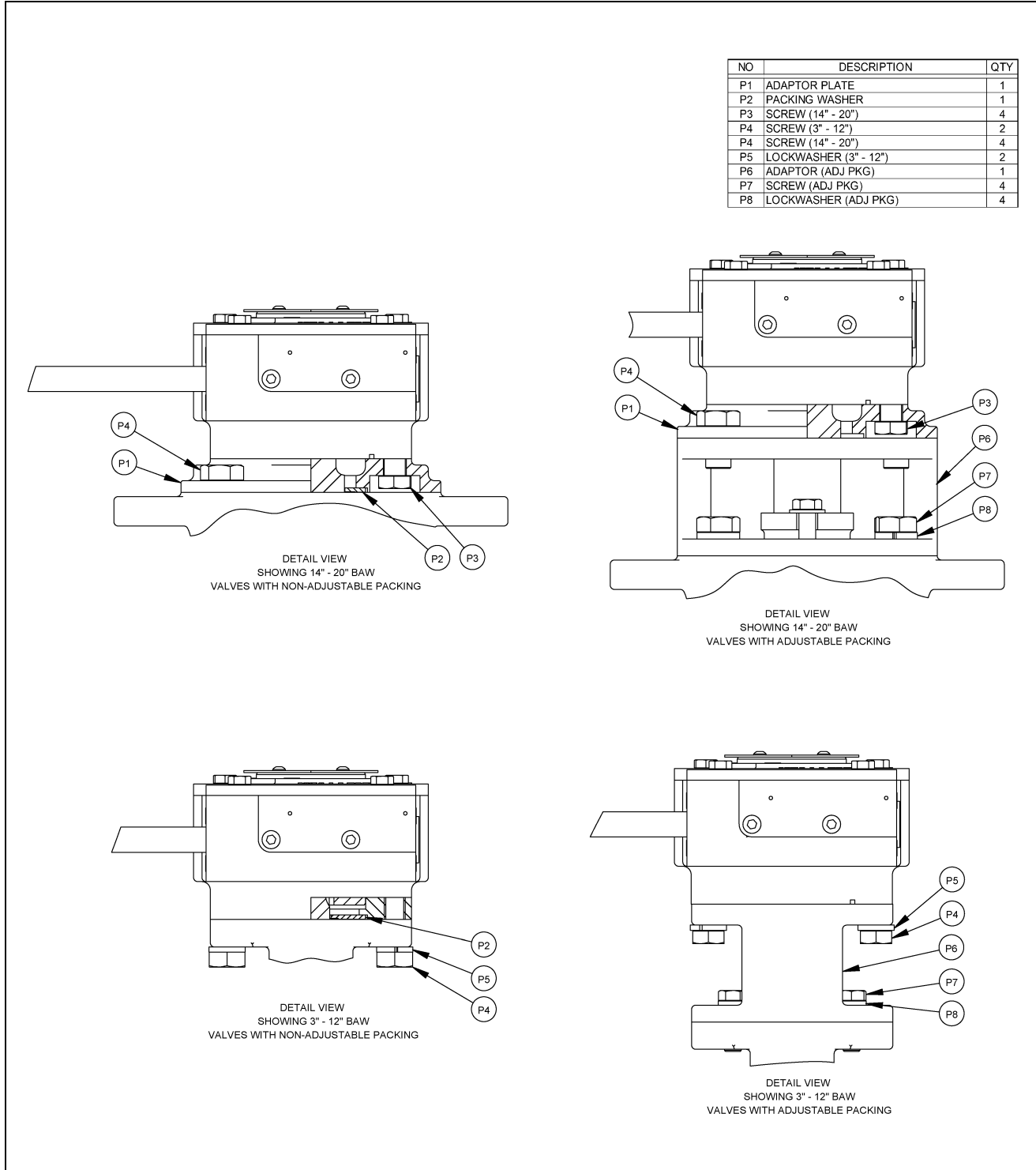

Figure 4 – Open and Closed Position Stop Identification

**G-Series (6B/12A) Manual Actuator
used on BAW Butterfly Valves**

Removing Actuator from Valve

Refer to Figure 5 (G_-6B) and Figure 6 (G_-12A) for connecting parts identification.



**G-Series (6B/12A) Manual Actuator
used on BAW Butterfly Valves**

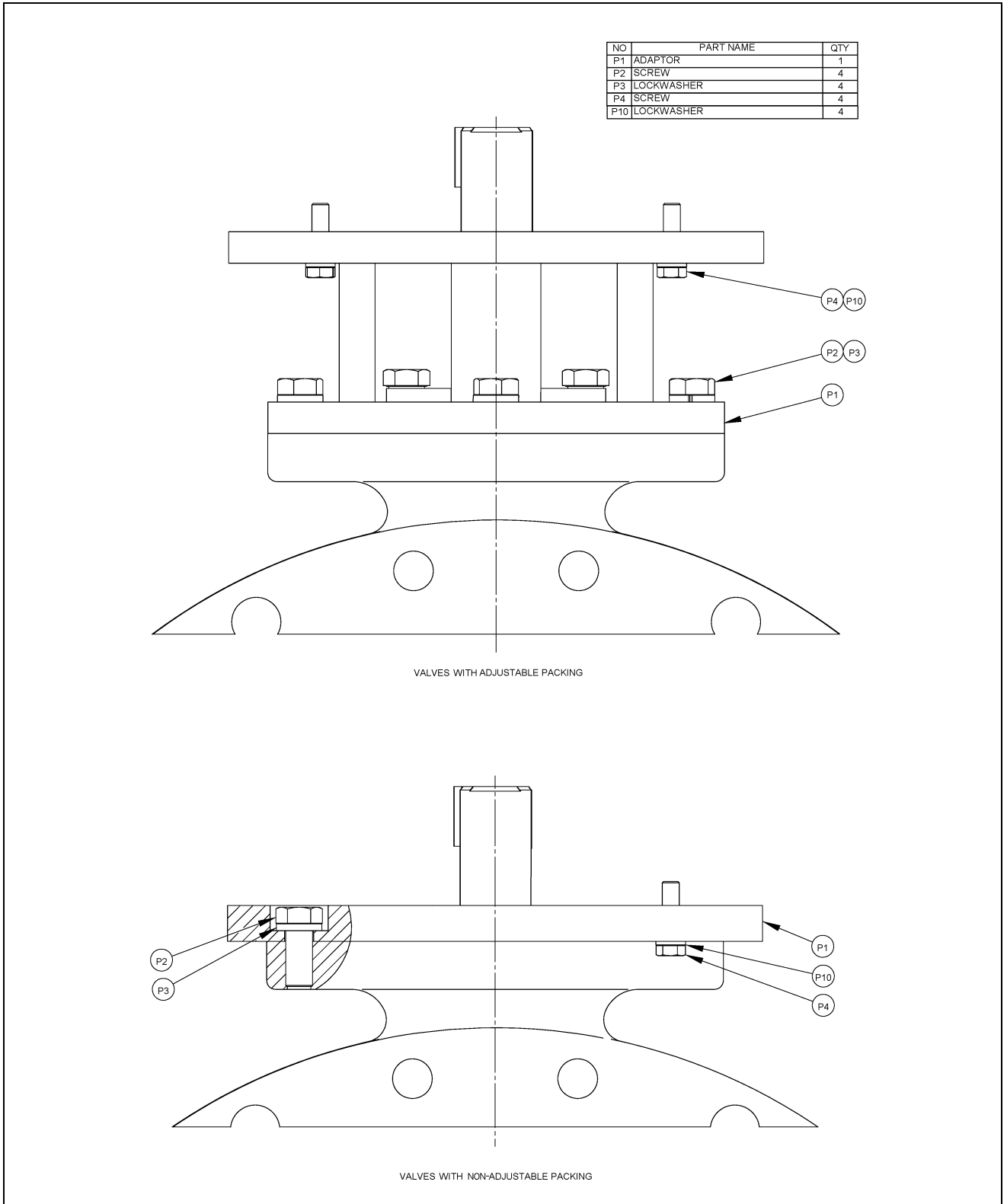

**Figure 6 – G_-12A Connecting Parts Identification
20” – 30” Valves**

Removing Actuator from Valve *(Continued)*



WARNING!

Flow in the pipeline with the actuator removed can slam the valve closed causing personal injury and damaging the flow system. Shut down the flow in the pipeline before removing the actuator from the valve.

G_-6B Actuator on 3 – 12 Inch Valves (Figure 5)

1. Discontinue flow and relieve pipeline pressure.
2. Close the valve.
3. Remove the two actuator mounting screws (P4) and lockwashers (P5).
4. Remove the actuator from the mounting flange.
5. Do not lose the drive key used in the valve shaft and actuator gear.

G_-6B Actuator on 14 – 20 Inch Valves (Figure 5)

1. Discontinue flow and relieve pipeline pressure.
2. Close the valve.
3. Remove the four adaptor mounting screws (P4).
4. Remove the actuator with adaptor plate (P1) from the mounting flange.
5. Do not lose the drive key used in the valve shaft and actuator gear.

G_-12A Actuator on 20 – 30 Inch Valves (Figure 6)

1. Discontinue flow and relieve pipeline pressure.
2. Close the valve.
3. Remove the four actuator mounting screws (P4) and lockwashers (P10).
4. Remove the actuator from the adaptor (P1).
5. Do not lose the drive key used in the valve shaft and actuator gear.

G-Series (6B/12A) Manual Actuator used on BAW Butterfly Valves

Installing Actuator on Valve

Refer to Figure 2 and Figure 5 for parts identification.

G_-6B Actuator on 3 – 12 Inch Valves

1. Place the valve in the position it was in when the actuator was removed. Normally this will be in the closed position.
2. **For Buried Service (GB_) actuators only:** Before reassembly, remove old sealant from all mating mounting surfaces. Apply a thin bead of silicone sealant DOW RTV-732 (1055515) or similar to the valve top mounting flange and the actuator housing (B1A) mounting surfaces.
3. **For Above Ground Service (GS_) actuators mounted on valves with non-adjustable packing only:** Verify the packing washer (P2) is located on the valve shaft.
4. Mount the actuator to the mounting flange with the two mounting screws (P4) and lockwashers (P5). Tighten screws.
Note: Verify the drive key in the valve shaft is inline with the keyway in the actuator gear before sliding the actuator onto the valve shaft.
5. Check the closed position stop setting and readjust if necessary as described in the STOP ADJUSTMENT Section of this Instruction.
6. Pipeline flow may now be restored.

G_-6B Actuator on 14 – 20 Inch Valves

1. Place the valve in the position it was in when the actuator was removed. Normally this will be in the closed position.
2. **For Buried Service (GB_) actuators only:** Before reassembly, remove old sealant from all mating mounting surfaces. Apply a thin bead of silicone sealant DOW RTV-732 (1055515) or similar to the adaptor plate (P1) and the actuator housing (B1A) mounting surfaces.
3. **For Above Ground Service (GS_) actuators mounted on valves with non-adjustable packing only:** Verify the packing washer (P2) is located on the valve shaft.
4. Mount the actuator to the adaptor with the four mounting screws (P4). Tighten screws.
Note: Verify the drive key in the valve shaft is inline with the keyway in the actuator gear before sliding the actuator onto the valve shaft.
5. Check the closed position stop setting and readjust if necessary as described in the STOP ADJUSTMENT Section of this Instruction.
6. Pipeline flow may now be restored.

Installing Actuator on Valve *(Continued)*

G_-12A Actuator on 20 – 30 Inch Valves

1. Place the valve in the position it was in when the actuator was removed. Normally this will be in the closed position.
2. **For Buried Service (GB_) actuators only:** Before reassembly, remove old sealant from all mating mounting surfaces. Apply a thin bead of silicone sealant DOW RTV-732 (1055515) or similar to the adaptor plate (P1) and the actuator housing (B1A) mounting surfaces.
3. Mount the actuator to the adaptor plate (P1) with the four mounting screws (P4) and lockwashers (P10). Tighten screws.

Note: Verify the drive key in the valve shaft is inline with the keyway in the actuator gear before sliding the actuator onto the valve shaft.

4. Check the closed position stop setting and readjust if necessary as described in the STOP ADJUSTMENT Section of this Instruction.
5. Pipeline flow may now be restored.

G-Series (6B/12A) Manual Actuator used on BAW Butterfly Valves

Actuator Disassembly and Assembly

Under normal operating conditions the G-Series actuator does not require routine maintenance. If the actuator has excessive wear or has been damaged, it is recommended that the actuator be replaced, not repaired.

Use the following procedure for replacing leaking seals and o-rings. Refer to Figure 2 for component identification.

Actuator Disassembly:



WARNING!

Flow in the pipeline with the actuator removed can slam the valve closed causing personal injury and damaging the flow system. Shut down the flow in the pipeline before removing the actuator from the valve.

1. Discontinue flow and relieve pipeline pressure.
2. Close the valve.
3. Remove the actuator from the valve as described in the REMOVING ACTUATOR FROM VALVE section of this Instruction.
4. **Above Ground Service (GS_) actuator only:** Note the position of the pointer (B1Q), then remove the screws (B1R) and pointer.

Buried Service (GB_) actuator only: Remove screws (B13) and cover (B12).
5. Remove the screws (B1M) and cover (B1B).
6. Remove the o-ring (B1N) thru the top of the cover (B1B).
7. Note the position of the gear (B1C) in the housing (B1A).
8. Remove the two pipe plugs (B1I) from the housing (B1A).
9. Rotate the drive shaft (B1F) until the pins (B1K) line up with the pipe plug holes in the housing (B1A).
10. Drive both pins (B1K) thru the worm (B1D) and drive shaft (B1F).
11. Slide the drive shaft (B1F) out of the housing (B1A).
12. Remove the worm gear (B1D), four bearing race (B1G), two thrust bearings (B1H), two spacer sleeves (B1V), gear (B1C) and seal (B1J) from the housing (B1A).
13. Remove the o-ring (B1N) thru the bottom of the housing (B1A).
14. Remove old gasket sealant from the top of the housing (B1A) and bottom of the cover (B1B).

Buried Service (GB_) actuator only: Remove old gasket sealant from the bottom of the housing (B1A), top of adaptor plate (P1), top of cover (B1B) and bottom of cover (B12) mating surfaces.

**G-Series (6B/12A) Manual Actuator
used on BAW Butterfly Valves**

Actuator Assembly:

1. Install a new seal (B1J) into the housing (B1A).
2. Apply a light film of grease to a new o-ring (B1N) and insert it into the groove in the bottom of the housing (B1A).
3. Grease the bearing (B1L) in the housing (B1A) and slide the gear (B1C) into the bearing in the position noted in Step 7. of the ACTUATOR DISASSEMBLY section.
4. Slide the drive shaft (B1F) into the housing (B1A) and thru bearing race (B1G), thrust bearing (B1H), bearing race (B1G), spacer sleeve (B1V), worm (B1D), bearing race (B1G), thrust bearing (B1H) and bearing race (B1G), spacer sleeve (B1V).
5. Rotate the drive shaft (B1F) until the pin holes in the drive shaft and the worm (B1D) line up.
6. Drive the two pins (B1K) thru the worm (B1D) and drive shaft (B1F).
7. Apply removable thread sealant to the threads of pipe plugs (B1I) and install the pipe plugs flush or below the surface of the housing (B1A).
8. **Above Ground Service (GS_) actuator only:** Apply a liberal amount of Lithium based grease such as Shell Alvania EP2 or Mobilux EP2 to the gear (B1C), bearings (B1L) and worm (B1D).

Buried Service (GB_) actuator only: Pack the housing (B1) full of Lithium based grease such as Shell Alvania EP2 or Mobilux EP2.
9. Apply a light film of grease to a new o-ring (B1N) and insert into groove in the cover (B1B).
10. Apply a bead of silicone sealant DOW RTV-732 (1055515) or similar to the housing (B1A) or cover (B1B) mating surface. Grease the bearing (B1L) in the cover, slide the cover onto the gear (B1C) and fasten with screws (B1M) to the housing.
11. Insert the drive key into the valve shaft/gear (B1C) keyway.
12. **Above Ground Service (GS_) actuator only:** Fasten the pointer (B1Q) to the gear (B1C) with the two screws (B1R) in the position noted in Step 4. of the ACTUATOR DISASSEMBLY section.

Buried Service (GB_) actuator only: Apply a bead of silicone sealant DOW RTV-732 (1055515) or similar to the cover (B12) or cover (B1B) mating surface. Fasten the cover (B12) to cover (B1B) with screws (B13).
13. Install the actuator on the valve as described in the REPLACING ACTUATOR ON VALVE Section of this Instruction.

**G-Series (6B/12A) Manual Actuator
used on BAW Butterfly Valves**

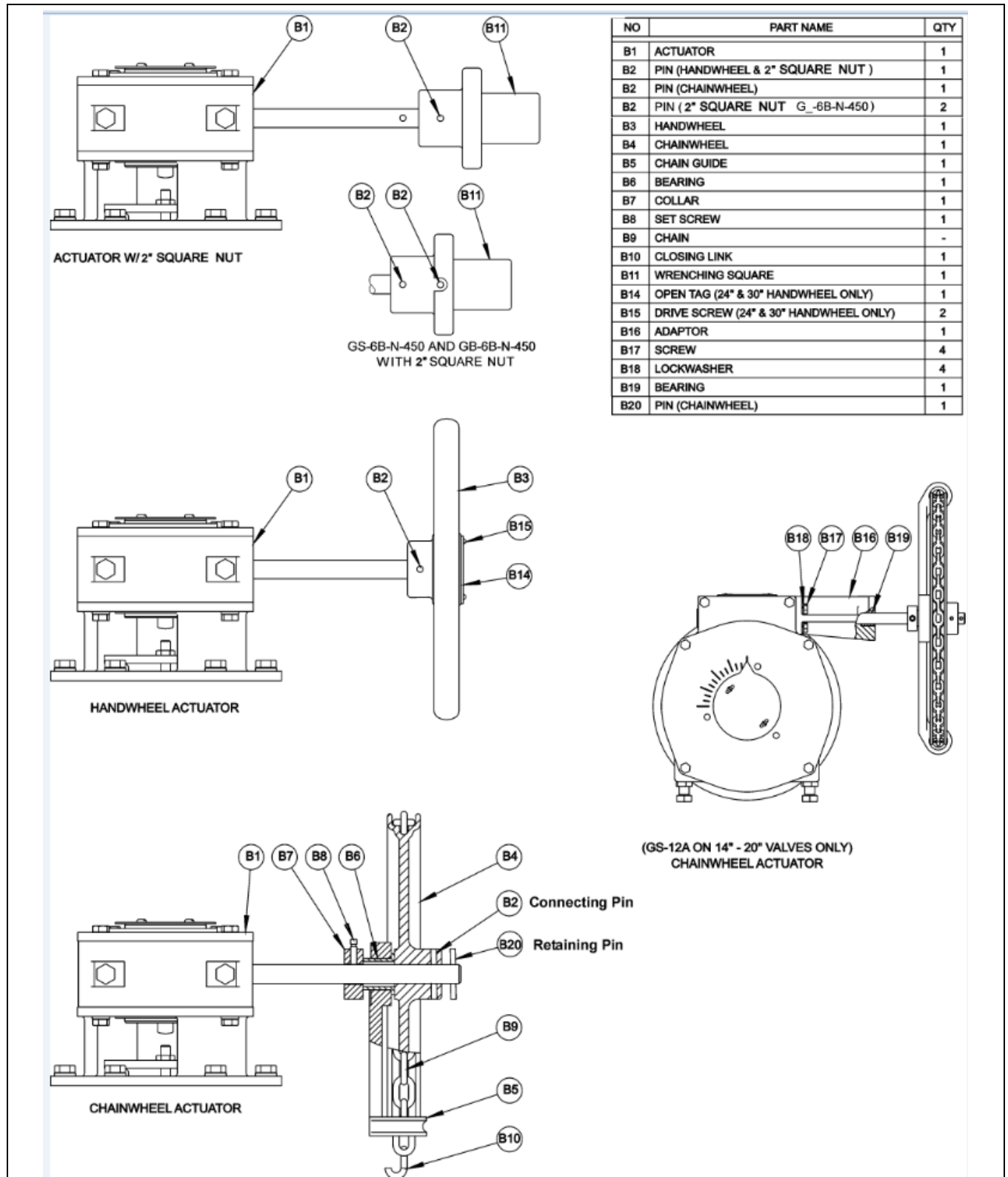

Figure 7 – G_-6B and G_-12A Operator Component Identification

**G-Series (6B/12A) Manual Actuator
used on BAW Butterfly Valves**

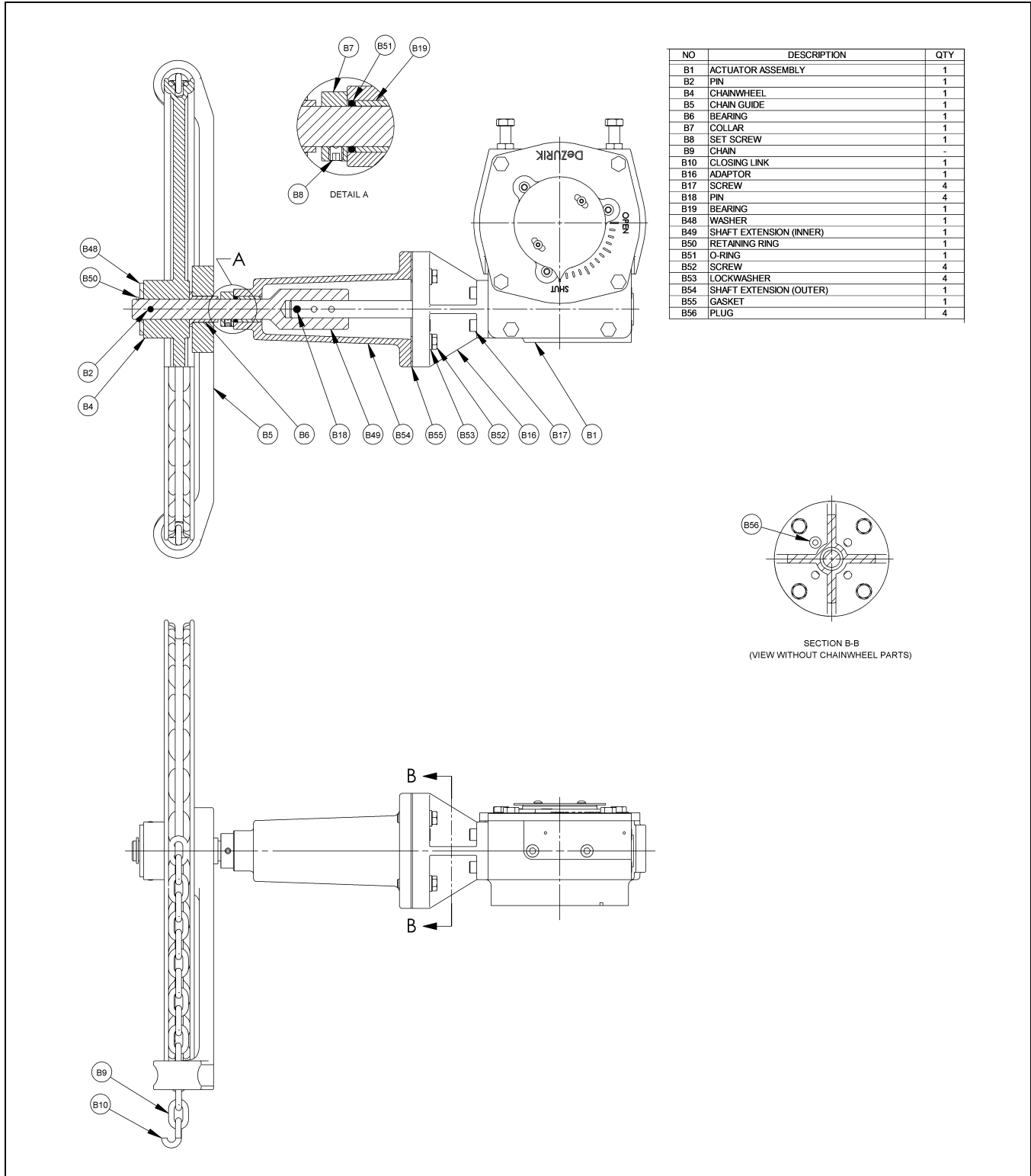

Figure 8 – G_-6B with 20” and 24” Chainwheels Operator Component Identification

G-Series (6B/12A) Manual Actuator used on BAW Butterfly Valves

Replace Handwheel or Nut with Chainwheel Operator

Carefully follow these steps to convert the actuator from a handwheel or nut operator to a chainwheel operator.



WARNING!

Flow in the pipeline with the actuator removed can slam the valve closed causing personal injury and damaging the flow system. Shut down the flow in the pipeline before removing the actuator from the valve.

1. Discontinue flow and relieve pipeline pressure.
2. Close the valve.
3. Remove actuator from valve. Refer to “Removing Actuator from Valve” section in this instruction.
4. Support actuator shaft (B1F) with a solid surface. Drive out pin (B2) and remove handwheel (B3) or nut (B11) from actuator shaft.

GS-6B-CW_ (8 and 12 Inch Chainwheels)

Refer to Figure 6 for parts identification.

1. Slide collar (B7) with set screw (B8) onto actuator shaft (B1F).
2. Insert bearing (B6) into chain guide (B5) and slide chain guide onto actuator shaft (B1F) with the bearing flange facing actuator and openings in chain guide facing away from actuator.
3. Slide chainwheel (B4) onto actuator shaft (B1F) with the pin hole in hub facing away from actuator and line up pin hole in chainwheel hub with second hole in actuator shaft. Support the hub of chainwheel with a solid surface and drive connecting pin (B2) into position. See Figure 6 for location of connecting pin.



WARNING!

The “connecting” pin securing the chainwheel hub to the actuator shaft could potentially shear allowing the chainwheel to disengage from the actuator shaft and cause personal injury or equipment damage.

A “retaining” pin at the end of the actuator shaft must be in-place to insure the chainwheel cannot disengage from the actuator shaft.

4. Support the hub of chainwheel (B4) with a solid surface and drive retaining pin (B20) into the remaining hole at the end of actuator shaft. See Figure 6 for location of retaining pin.
5. Slide collar (B7) and chain guide (B5) against chainwheel (B4) and tighten set screw (B8).
6. Install actuator on valve. Refer to “Installing Actuator on Valve” section in this instruction.
7. Feed chain (B9) over chainwheel (B4) and through both openings in chain guide (B5).
8. Connect ends of chain (B9) with closing link (B10).

Replace Handwheel or Nut with Chainwheel Operator *(Continued)*

GS-6B-CW_ (20 and 24 Inch Chainwheels)

Refer to Figure 8 for parts identification.

1. Remove plastic plugs from mounting holes on shaft side of actuator housing (B1A).
2. Slide adaptor (B16) onto actuator shaft (B1F). Tighten with screws (B17).
3. Slide inner shaft extension (B49) onto actuator shaft (B1F) and align pin holes.
4. Support the hub of inner shaft extension (B49) with a solid surface and drive pin (B18) into the aligned pin holes.
5. Insert bearing (B19) in hole of outer shaft extension (B54).
Note: Bearing must be recessed .18" from end of outer shaft extension.
6. Place gasket (B55) on adaptor (B16).
7. Slide outer shaft extension (B54) onto inner shaft extension (B49).
8. Align gasket (B55) and outer shaft extension (B54) with adaptor (B16). Secure outer shaft extension to adaptor with screws (B52) and lockwashers (B53).
9. Apply a light film of grease to a new o-ring (B51) and slide over inner shaft extension (B49) and insert into outer shaft extension (B54) o-ring groove.
10. Slide collar (B7) with set screw (B8) onto inner shaft extension (B49) and secure up against outer shaft extension (B54).
11. Insert the four plugs (B56) into thru holes in adaptor (B16).
12. Insert bearing (B6) into chain guide (B5) and slide chain guide onto inner shaft extension (B49) with the bearing flange and openings in chain guide facing away from actuator.
13. Slide chainwheel (B4) onto inner shaft extension (B49) with pin hole in hub facing away from actuator. Line up pin hole in chainwheel hub with hole in inner shaft extension. Support hub of chainwheel with a solid surface and drive pin (B2) into position.



WARNING!

The “connecting” pin securing the chainwheel hub to the inner shaft extension could potentially shear allowing the chainwheel to disengage from the actuator shaft and cause personal injury or equipment damage.

A washer and retaining ring must be in-place to insure the chainwheel cannot disengage from the inner shaft extension.

14. Slide washer (B48) onto inner shaft extension (B49) and attach retaining ring (B50) to inner shaft extension.
15. Install actuator on valve. Refer to “Installing Actuator on Valve” section in this instruction.
16. Feed chain (B9) over chainwheel (B4) and through both openings in chain guide (B5).
17. Connect the ends of chain (B9) with closing link (B10).

Replace Handwheel or Nut with Chainwheel Operator *(Continued)*

GS-12A-CW_

Refer to Figure 6 for parts identification.

1. Remove plastic plugs from mounting holes on shaft side of actuator housing (B1A).
2. Slide adaptor (B16) onto actuator shaft (B1F). Tighten with screws (B17) and lockwashers (B18).
3. Slide collar (B7) with set screw (B8) onto actuator shaft (B1F).
4. Insert bearing (B6) into chain guide (B5) and slide chain guide onto actuator shaft (B1F) with the bearing flange facing actuator and chain holes in guide facing away from actuator.
5. Slide chainwheel (B4) onto actuator shaft (B1F) with pin hole in hub facing away from actuator and line up pin hole in chainwheel hub with second hole in actuator shaft. Support the hub of chainwheel with a solid surface and drive connecting pin (B2) into position. See Figure 7 for location of connecting pin.



WARNING!

The connecting pin securing the chainwheel hub to the actuator shaft could potentially shear allowing the chainwheel to disengage from the actuator shaft and cause personal injury or equipment damage.

A retaining pin at the end of the actuator shaft must be in-place to insure the chainwheel cannot disengage from the actuator shaft.

6. Support hub of chainwheel (B4) with a solid surface and drive retaining pin (B20) into remaining hole at end of actuator shaft. See Figure 6 for location of retaining pin.
7. Slide collar (B7) and chain guide (B5) against chain wheel (B4) and tighten set screw (B8).
8. Install actuator on valve. Refer to "Installing Actuator on Valve" section in this instruction.
9. Feed chain (B9) over chainwheel (B4) and through both openings in chain guide (B5).
10. Connect ends of chain (B9) with closing link (B10).

Changing Mounting Positions

The actuator can be mounted in 90° increments around the valve shaft.

To move the actuator mounting position in 90° increments from its present position, follow these steps.

1. Remove the actuator from the valve as described in the REMOVING ACTUATOR FROM VALVE Section of this Instruction.
2. Rotate the actuator to the desired position.

Install the actuator on the valve as described in the INSTALLING ACTUATOR ON VALVE Section of this Instruction.

Troubleshooting

Condition	Possible Cause	Corrective Action
Actuator closes to wrong position	Closed position stop is set incorrectly	Adjust closed position stop. See <i>Adjusting Position Stops</i> section
	Pointer is installed incorrectly.	Rotate pointer to correct position.
Actuator opens to wrong position	Open position stop is set incorrectly	Adjust open position stop. See <i>Adjusting Position Stops</i> section
	Pointer is installed incorrectly.	Rotate pointer to correct position.
High operating torque.	Misalignment of adaptor.	Check valve-adaptor-actuator alignment and adjust.
	Misalignment of ENK extension.	Check valve-extension-actuator alignment and adjust.
	Bent actuator input shaft.	Replace actuator.