

# **Model Q45P**

## **External DC Power pH Transmitter**

---

### **Home Office**

Analytical Technology, Inc.  
6 Iron Bridge Drive  
Collegeville, PA 19426

Ph: 800-959-0299  
610-917-0991

Fax: 610-917-0992

Email: [sales@analyticaltechnology.com](mailto:sales@analyticaltechnology.com)

### **European Office**

ATI (UK) Limited  
Unit 1 & 2 Gatehead Business Park  
Delph New Road, Delph  
Saddleworth OL3 5DE

Ph: +44 (0)1457-873-318

Fax: + 44 (0)1457-874-468

Email: [sales@atiuk.com](mailto:sales@atiuk.com)

---

# PRODUCT WARRANTY

Analytical Technology, Inc. (Manufacturer) warrants to the Customer that if any part(s) of the Manufacturer's products proves to be defective in materials or workmanship within the earlier of 18 months of the date of shipment or 12 months of the date of start-up, such defective parts will be repaired or replaced free of charge. Inspection and repairs to products thought to be defective within the warranty period will be completed at the Manufacturer's facilities in Collegeville, PA. Products on which warranty repairs are required shall be shipped freight prepaid to the Manufacturer. The product(s) will be returned freight prepaid and allowed if it is determined by the manufacturer that the part(s) failed due to defective materials or workmanship.

This warranty does not cover consumable items, batteries, or wear items subject to periodic replacement including lamps and fuses.

Gas sensors, except oxygen sensors, are covered by this warranty, but are subject to inspection for evidence of extended exposure to excessive gas concentrations. Should inspection indicate that sensors have been expended rather than failed prematurely, the warranty shall not apply.

The Manufacturer assumes no liability for consequential damages of any kind, and the buyer by acceptance of this equipment will assume all liability for the consequences of its use or misuse by the Customer, his employees, or others. A defect within the meaning of this warranty is any part of any piece of a Manufacturer's product which shall, when such part is capable of being renewed, repaired, or replaced, operate to condemn such piece of equipment.

This warranty is in lieu of all other warranties (including without limiting the generality of the foregoing warranties of merchantability and fitness for a particular purpose), guarantees, obligations or liabilities expressed or implied by the Manufacturer or its representatives and by statute or rule of law.

This warranty is void if the Manufacturer's product(s) has been subject to misuse or abuse, or has not been operated or stored in accordance with instructions, or if the serial number has been removed.

Analytical Technology, Inc. makes no other warranty expressed or implied except as stated above.

# Table of Contents

---

<b>PART 1 - INTRODUCTION.....4</b>	<b>PART 5 – CONFIGURATION..... 35</b>
1.1 General (Q45P, pH Monitor).....4	5.1 User Interface ..... 35
1.2 Features .....5	5.11 Keys ..... 36
1.3 Q45P System Specifications .....5	5.12 Display ..... 36
1.4 Q45P Performance Specifications .....6	5.2 Software..... 38
1.5 General – Q25P pH Sensor.....7	5.21 Software Navigation ..... 38
1.6 Sensor Features .....7	5.22 Measure Menu [MEASURE] ..... 41
1.7 Q25P Sensor Specifications .....7	5.23 Calibration Menu [CAL]..... 42
<b>PART 2 – ANALYZER MOUNTING.....9</b>	5.24 Configuration Menu [CONFIG].. 43
2.1 General.....9	5.25 Control Menu [CONTROL] ..... 46
2.2 Wall or Pipe Mount ..... 11	<b>PART 6 – CALIBRATION ..... 50</b>
<b>PART 3 – SENSOR/FLOWCELL MOUNTING.....13</b>	6.1 Overview and Methods ..... 50
3.1 General..... 13	6.11 Sensor Slope ..... 50
3.2 Flow Tee Mounting ..... 14	6.12 Sensor Offset ..... 51
3.3 Union Mounting..... 15	6.13 2-Point Calibration Explained.... 51
3.5 Submersion Mounting ..... 17	6.14 1-Point Calibration Explained.... 51
3.6 Insertion Mounting ..... 18	6.2 Performing a 2-Point Calibration..... 52
3.7 Conventional pH Sensors ..... 20	6.3 Performing a 1-Point Calibration..... 53
3.71 Sealed Flowcell..... 21	6.4 Temperature Calibration ..... 55
3.72 Flow Tee Adapter ..... 22	<b>PART 7 – MAINTENANCE AND TROUBLESHOOTING ..... 56</b>
3.8 Lock-n-Load System..... 23	7.1 System Checks ..... 56
<b>PART 4 – ELECTRICAL INSTALLATION...24</b>	7.2 Instrument Checks ..... 56
4.1 General..... 24	7.4 Cleaning the Sensor..... 61
4.2 External Power ..... 24	7.5 Replacing the Saltbridge and Reference Buffer Solution ..... 62
4.3 Voltage Outputs ..... 27	7.6 Troubleshooting ..... 63
4.4 Sensor Wiring ..... 27	<b>SPARE PARTS ..... 65</b>
4.5 Direct Sensor Connection ..... 29	
4.6 Junction Box Connection ..... 30	
4.7 Combination Electrode Connection ..... 31	
4.7 External Temperature Compensation ..... 33	
4.8 External Preamplifier ..... 34	

# Table of Figures

---

<i>FIGURE 1 - Q45 ENCLOSURE DIMENSIONS .....</i>	<i>10</i>
<i>FIGURE 2 - MOUNTING BRACKET DIMENSIONS.....</i>	<i>11</i>
<i>FIGURE 3 - WALL MOUNTING DIAGRAM .....</i>	<i>12</i>
<i>FIGURE 4 - PIPE MOUNTING DIAGRAM.....</i>	<i>12</i>
<i>FIGURE 5 - Q25 SENSOR TYPES.....</i>	<i>13</i>
<i>FIGURE 6 - FLOW THROUGH TEE MOUNT .....</i>	<i>14</i>
<i>FIGURE 7 - 1.5" UNION MOUNT.....</i>	<i>15</i>
<i>FIGURE 8 - 2" UNION MOUNT.....</i>	<i>16</i>
<i>FIGURE 9 - SENSOR SUBMERSION MOUNT .....</i>	<i>17</i>
<i>FIGURE 10 - S.S. SENSOR INSERTION MOUNT.....</i>	<i>18</i>
<i>FIGURE 11 - CPVC SENSOR INSERTION MOUNT.....</i>	<i>19</i>
<i>FIGURE 12 - (63-0013) COMBINATION PH SENSOR, FLOW TYPE.....</i>	<i>20</i>
<i>FIGURE 13 - (63-0009) COMBINATION PH SENSOR, SUB. TYPE.....</i>	<i>20</i>
<i>FIGURE 14 - SEALED FLOWCELL DETAILS.....</i>	<i>21</i>
<i>FIGURE 15 - TWIST-LOCK FLOW TEE .....</i>	<i>22</i>
<i>FIGURE 16 - LOCK-N-LOAD SENSOR EXPLODED VIEW.....</i>	<i>23</i>
<i>FIGURE 17 - DC/LOOP POWER WIRING DIAGRAM.....</i>	<i>25</i>
<i>FIGURE 18 - EXTERNAL POWER BOARD .....</i>	<i>27</i>
<i>FIGURE 19 - CABLE DESCRIPTION, MODEL Q25P .....</i>	<i>28</i>
<i>FIGURE 20 - DETACHABLE SINGLE SHIELDED CABLE, MODEL Q25P .....</i>	<i>28</i>
<i>FIGURE 21 - SENSOR CABLE PREPARATION .....</i>	<i>29</i>
<i>FIGURE 22 - JUNCTION BOX INTERCONNECT WIRING .....</i>	<i>30</i>
<i>FIGURE 23 - SENSOR CONNECTIONS, COMBINATION ELECTRODES.....</i>	<i>31</i>
<i>FIGURE 24 - COMBINATION ELECTRODE CONNECTIONS .....</i>	<i>32</i>
<i>FIGURE 25 - EXTERNAL TEMPERATURE COMPENSATION .....</i>	<i>33</i>
<i>FIGURE 26 - EXTERNAL PREAMP FOR CONVENTIONAL SENSOR WIRING.....</i>	<i>34</i>
<i>FIGURE 27 - USER INTERFACE.....</i>	<i>35</i>
<i>FIGURE 28 - SOFTWARE MAP .....</i>	<i>40</i>
<i>FIGURE 29 - AUTOMATIC PH BUFFER TABLES.....</i>	<i>45</i>
<i>FIGURE 31 - REPLACING THE SALTBRIDGE AND REFERENCE BUFFER .....</i>	<i>62</i>

# Part 1 - Introduction

---

## 1.1 General (Q45P, pH Monitor)

The Model Q45P provides continuous measurement of pH in aqueous systems. It is suitable for potable water, wastewater, and a wide variety of process water applications. Q45P monitors may be used with Q25P “differential” pH sensors or a variety of conventional “combination” pH sensors.

Monitors are available in three electronic versions, a loop-powered 2-wire transmitter, a dual “AA” battery operated portable unit with two voltage outputs, and a 5-17 VDC Externally powered unit with two voltage outputs. This manual refers to the External Power transmitter version.

In all configurations, the Q45P displays pH, sensor temperature, sensor output millivolts, and output voltage on the secondary line of the custom display.



**WARNING: Not following operating instructions may impair safety.**

## 1.2 Features

- Q45P electronic transmitters are fully isolated, externally powered for VDC applications.
- Output Hold, Output Simulate, Output Alarm, and Output Delay Functions. All forced changes in output condition include bumpless transfer for gradual return to on-line signal levels to avoid system control shocks on both analog outputs.
- Selectable Output Fail Alarm feature allows system diagnostic failures to be sent to external monitoring systems.
- Large, high contrast, custom LCD display with LED back light provides excellent readability in any light conditions. The second line of display utilizes 5x7 dot matrix characters for clear message display. Two of four measured parameters may be on the display simultaneously.
- Diagnostic messages provide a clear description of any problem with no confusing error codes to look up. Messages are also included for diagnosing calibration problems.
- Two-point and sample calibration methods include auto-buffer recognition from 13 built-in buffer tables, with stability checks during calibration.
- Selectable Pt1000 or Pt100 temperature inputs.
- Security lock feature to prevent unauthorized tampering.

## 1.3 Q45P System Specifications

<b>Enclosure</b>	NEMA 4X, polycarbonate, stainless steel hardware, weatherproof and corrosion resistant.
<b>Mounting Options</b>	Wall or pipe mount bracket standard. Bracket suitable for either 1.5" or 2" I.D. U-Bolts for pipe mounting.
<b>Weight</b>	1 lb. (0.45 kg)
<b>Display</b>	0.75" (19.1 mm) high 4-digit main display with sign 12-digit secondary display, 0.3" (7.6 mm) 5x7 dot matrix.
<b>Keypad</b>	4-key membrane type, polycarbonate
<b>Ambient Temperature</b>	Service, -20 to 60 °C (-4 to 140 °F) Storage, -30 to 70 °C (-22 to 158 °F)
<b>Ambient Humidity</b>	0 to 95%, indoor/outdoor use, non-condensing.

<b>Altitude</b>	Maximum 2000 m (6562 Ft.)
<b>Electrical Certification</b>	Ordinary Location, cCSAus (CSA and UL standards - both approved by CSA), pollution degree 2, installation category 2
<b>EMI/RFI Influence</b>	Designed to EN 61326-1
<b>Output Isolation</b>	600 V galvanic isolation
<b>Filter (Damping)</b>	Adjustable 0-9.9 minutes damping to 90% step input change.
<b>Temperature Input</b>	Selectable Pt1000 or Pt100 RTD with automatic compensation
<b>Displayed Parameters</b>	Main input, 0.00 to 14.00 pH Sensor temperature, -10.0 to 110.0 °C (14 to 230°F) Voltage Outputs, 0-2.5V Sensor slope/offset Model number and software version
<b>Power</b>	5-17 VDC
<b>Conduit Openings</b>	Two PG-9 openings with gland seals
<b>DC Cable Type</b>	Belden twisted-pair, shielded, 22 gauge or larger

#### 1.4 Q45P Performance Specifications

<b>Accuracy</b>	0.1% of span or better ( $\pm 0.01$ pH)
<b>Repeatability</b>	0.1% of span or better ( $\pm 0.01$ pH)
<b>Sensitivity</b>	0.05% of span ( $\pm 0.01$ pH)
<b>Stability</b>	0.05% of span per 24 hours, non-cumulative
<b>Supply Voltage Effects</b>	$\pm 0.05\%$ span
<b>Instrument Response Time</b>	6 seconds to 90% of step input at lowest setting
<b>Temperature Drift</b>	Span or zero, 0.02% of span/°C
<b>Max. Sensor-Instrument Distance</b>	3,000 ft. (914 meters) w/ preamp, 30 ft. (9.1 meters) w/o preamp
<b>Sensor Types</b>	Model Q25P pH w/ preamp - 5 wire input, or combination style pH electrode w/ TC

## 1.5 General – Q25P pH Sensor

The Model Q25P is a “differential” pH sensor designed for the measurement of pH of aqueous solutions. The differential design utilizes a second glass measuring electrode contained in an internal buffer as the reference element. This eliminates the need for a silver/silver chloride reference used in conventional pH sensor designs. It is designed to perform in the harshest of environments, including applications that poison conventional pH sensors. All seals are dual o-ring using multiple sealing materials.

## 1.6 Sensor Features

- A high volume, dual junction saltbridge to maximize the in-service lifetime of the sensor. The annular junction provides a large surface area to minimize the chance of fouling. Large electrolyte volume and dual reference junctions minimize contamination. The saltbridge is replaceable.
- An integral preamplifier encapsulated in the provides a low impedance signal output which ensures stable readings in noisy environments. Sensor to transmitter separation can be up to 3,000 feet (914 meters).
- Pt1000 RTD. The temperature element used in ATI sensors is highly accurate and provides a highly linear output.
- Available in various configurations including submersible, flow type with quick disconnect, sanitary, and insertion.

## 1.7 Q25P Sensor Specifications

<b>Measuring Range</b>	0 to 14.00 pH
<b>Sensitivity</b>	0.01 pH
<b>Stability</b>	0.02 pH per 24 hours, non-cumulative
<b>Wetted Materials</b>	PEEK, ceramic, titanium, glass, Viton, EDPM (optional: 316 stainless steel body)
<b>Temperature Compensation</b>	Pt1000 RTD
<b>Sensor Cable</b>	6 Conductor (5 are used) plus 2 shields, 15 feet (4.6 meters) standard length
<b>Temperature Range</b>	-5 to +95 °C (23 to 203 °F)
<b>Pressure Range</b>	0 to 100 psig



<b>Maximum Flow Rate</b>	10 feet (3 meters) per second
<b>Sensor to Analyzer Distance</b>	3,000 feet (914 meters) maximum
<b>Sensor Body Options</b>	1" NPT convertible, 1¼" insertion, 1½" or 2" sanitary-style
<b>Weight</b>	1 lb. (0.45 kg)

**Notes:** 1. The type of hardware used to mount the sensor may limit the maximum temperature and pressure ratings. Please consult the hardware manufacturer's specifications to obtain the relevant temperature and pressure rating information.

2. The maximum flow rate specification is lower for process solutions with low ionic conductivity or high suspended solids concentration. High flow rates in low ionic conductivity processes may cause a measurement error due to static electrical discharge. High flow rates in processes with high suspended solids concentration may decrease the functional life of the sensor by eroding the pH-sensitive glass electrode.

### 1.8 Important Sensor Notes

- The glass electrode must be wetted at all times to ensure proper functionality. Q25P sensors are shipped with a fluid-filled cap over the electrode to enable immediate use (remove cap before installing, save for storage and shipping purposes). Electrodes that have dried out for any reason should be hydrated for 24 hours to restore full functionality.
- Hydrofluoric acid (HF) will dissolve conventional glass electrodes. For applications involving hydrofluoric acid, a pH sensor with antimony electrode is recommended.



**NOTE:** The standard Q25P process electrode is made of glass and can break if not handled properly. Should the electrode ever break, **USE CAUTION** when handling the sensor to avoid serious cuts.



Equipment bearing this marking may not be discarded by traditional methods in the European community after August 12 2005 per EU Directive 2002/96/EC. End users must return old equipment to the manufacturer for proper disposal.

## Part 2 – Analyzer Mounting

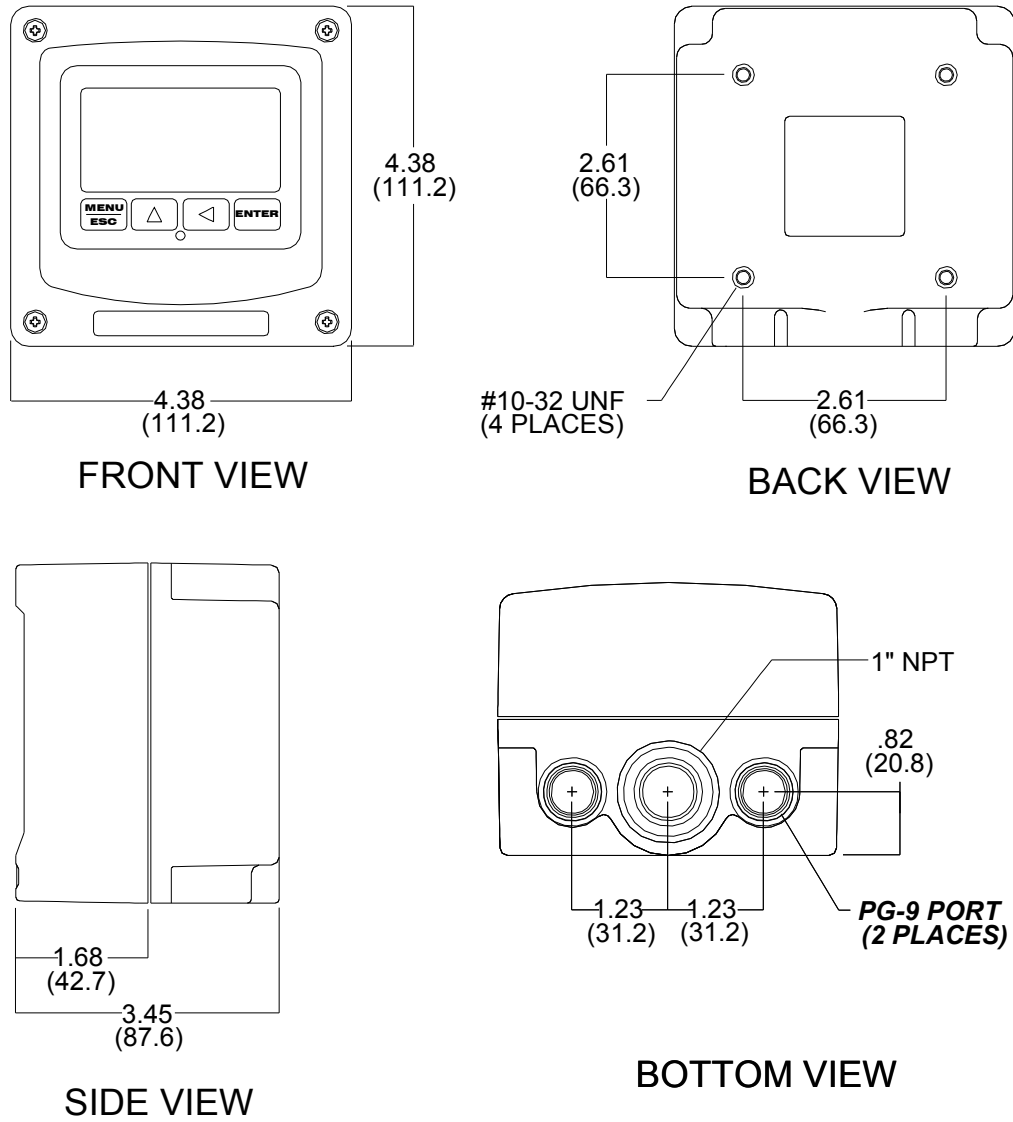
---

### 2.1 General

All Q45 Series instruments provide for mounting flexibility. A bracket is included that allows mounting to walls or pipes. In all cases, choose a location that is readily accessible for calibrations. Also consider that it may be necessary to utilize a location where solutions can be used during the calibration process. To take full advantage of the high contrast display, mount the instrument in a location where the display can be viewed from various angles and long distances.

Locate the instrument in close proximity to the point of sensor installation - this will allow easy access during calibration. The standard cable length of the pH sensor is 15 feet. For sensor cables longer than 30 feet, use the optional junction box (07-0100) and sensor interconnect cable (31-0057).

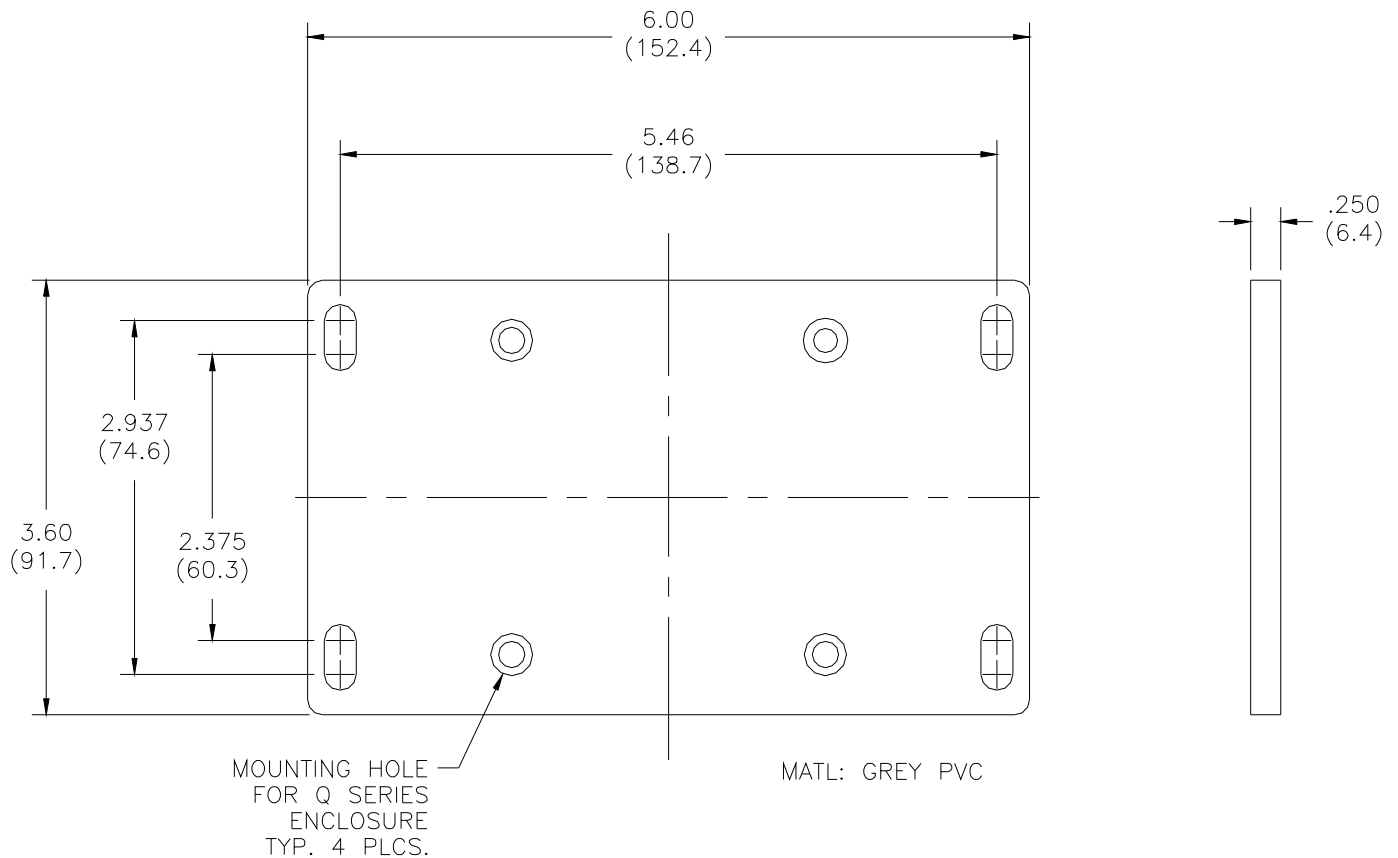
Refer to Figure 3 and Figure 4 for detailed dimensions of each type of system.



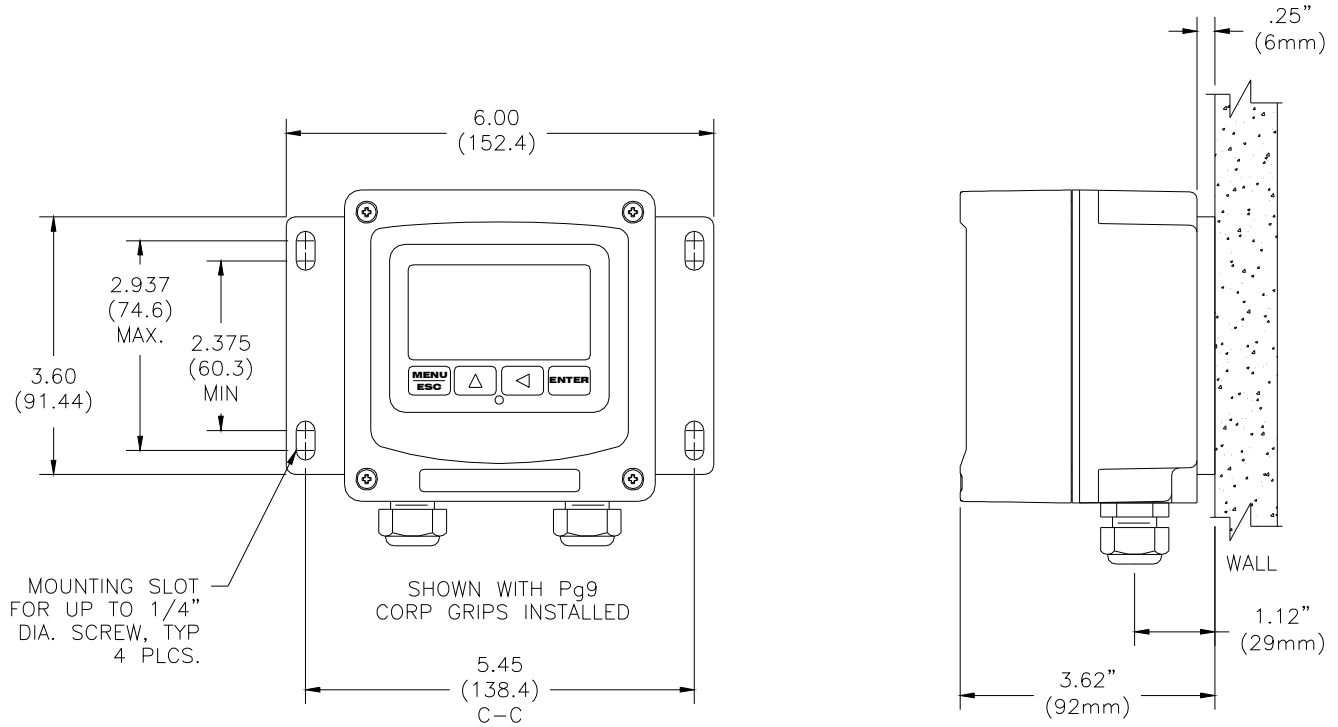
**Figure 1 - Q45 Enclosure Dimensions**

## 2.2 Wall or Pipe Mount

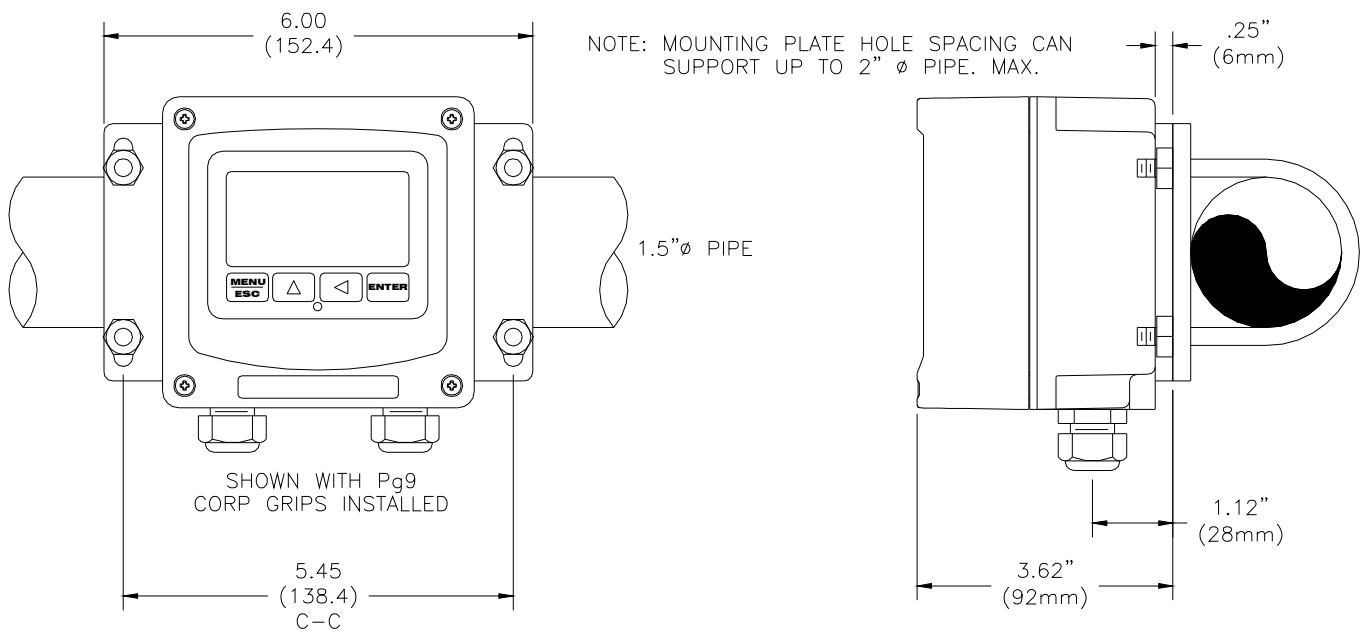
A PVC mounting bracket with attachment screws is supplied with each transmitter. The multi-purpose bracket is attached to the rear of the enclosure using the four flat head screws. The instrument is then attached to the wall using the four outer mounting holes in the bracket. These holes are slotted to accommodate two sizes of u-bolt that may be used to pipe mount the unit. Slots will accommodate u-bolts designed for 1½ "or 2" pipe. The actual center to center dimensions for the u-bolts are shown in the drawing. Note that these slots are for u-bolts with ¼-20 threads. The 1½" pipe u-bolt (2" I.D. clearance) is available from ATI in type 304 stainless steel under part number (47-0005).



**Figure 2 - Mounting Bracket Dimensions**



**Figure 3 - Wall Mounting Diagram**



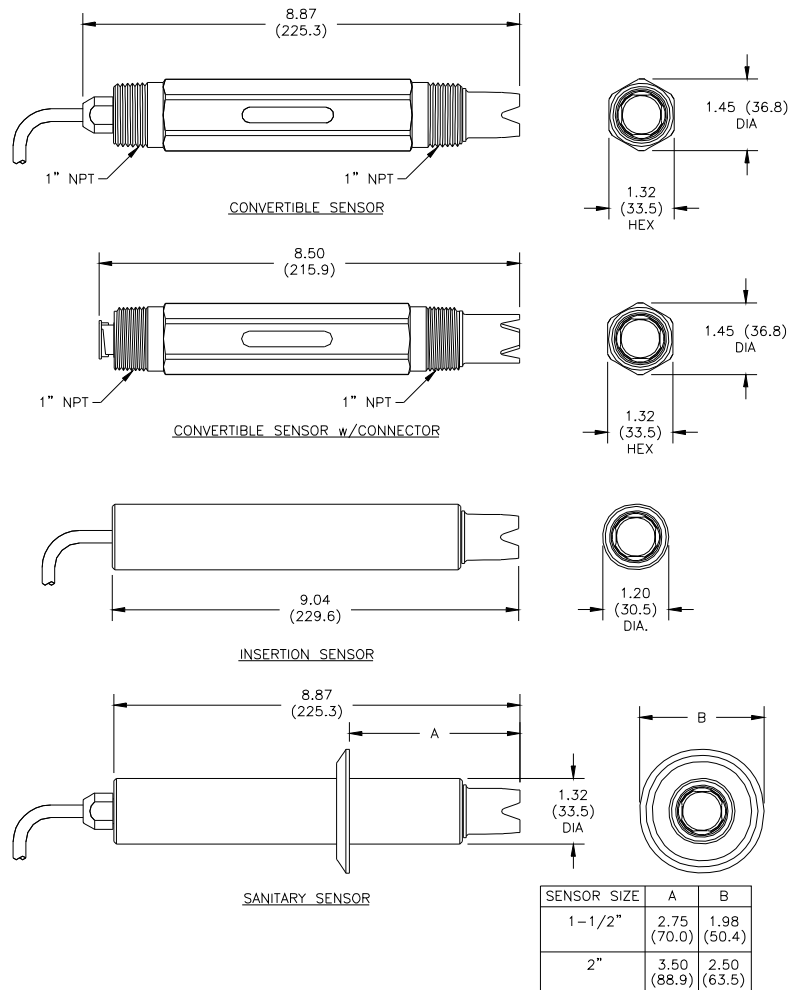
**Figure 4 - Pipe Mounting Diagram**

## Part 3 – Sensor/Flowcell Mounting

### 3.1 General

The Q25P pH Sensor mounting options include flow-through, submersion, insertion (special hardware required), or sanitary mount depending on the type of sensor purchased.

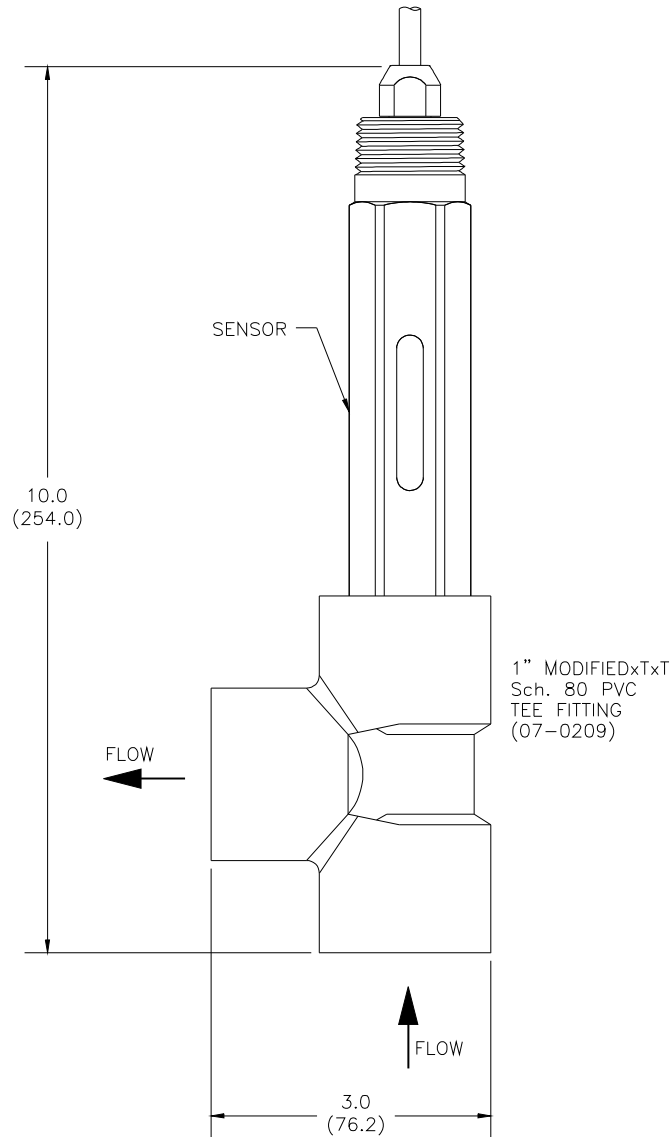
Q25P Differential pH Sensors are available in 4 different versions as shown in Figure 5. The convertible style is the most common and can be used for either flow-through or submersion applications. A convertible sensor with a quick-disconnect receptacle is available. This version may not be submerged and should not be used in unprotected outdoor locations. For special applications, the Q25P is also available in a stainless steel bodied version for insertion type installations, or can be supplied in either 1.5" or 2" sanitary versions.



**Figure 5 - Q25 Sensor Types**

**3.2 Flow Tee Mounting**

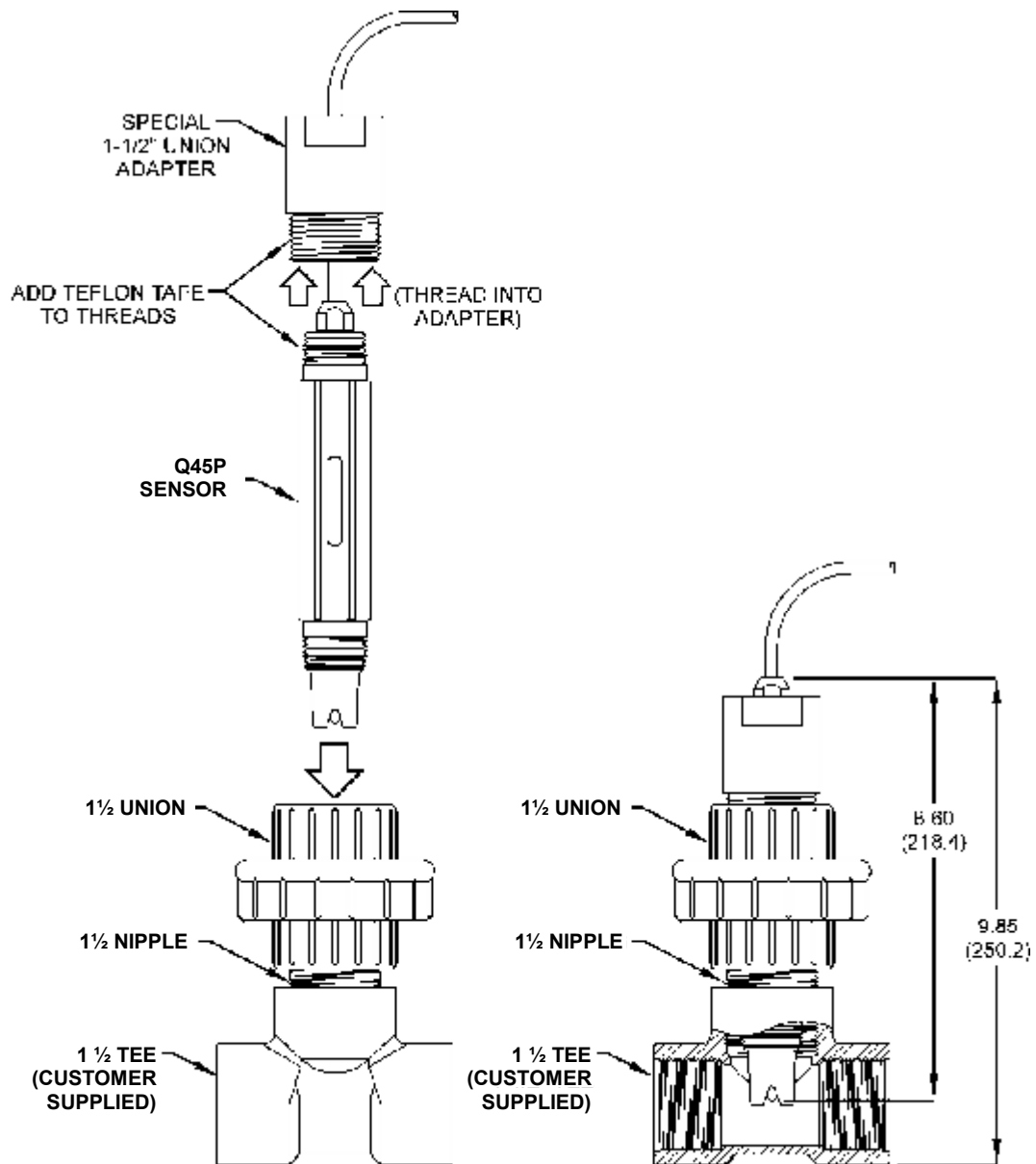
Convertible sensors may be used in a 1" flow tee as shown in Figure 6. The flow tee is a modified pipe fitting that accommodates the pipe thread on the front of the sensor. Sample must flow directly against the face of the sensor as shown. The sensor may be mounted horizontally provided that the outlet flow is pointed up to avoid "air locking" in the tee. Note that standard 1" tee fittings will not work without modification due to clearance problems in most molded tees.



**Figure 6 - Flow Through Tee Mount**

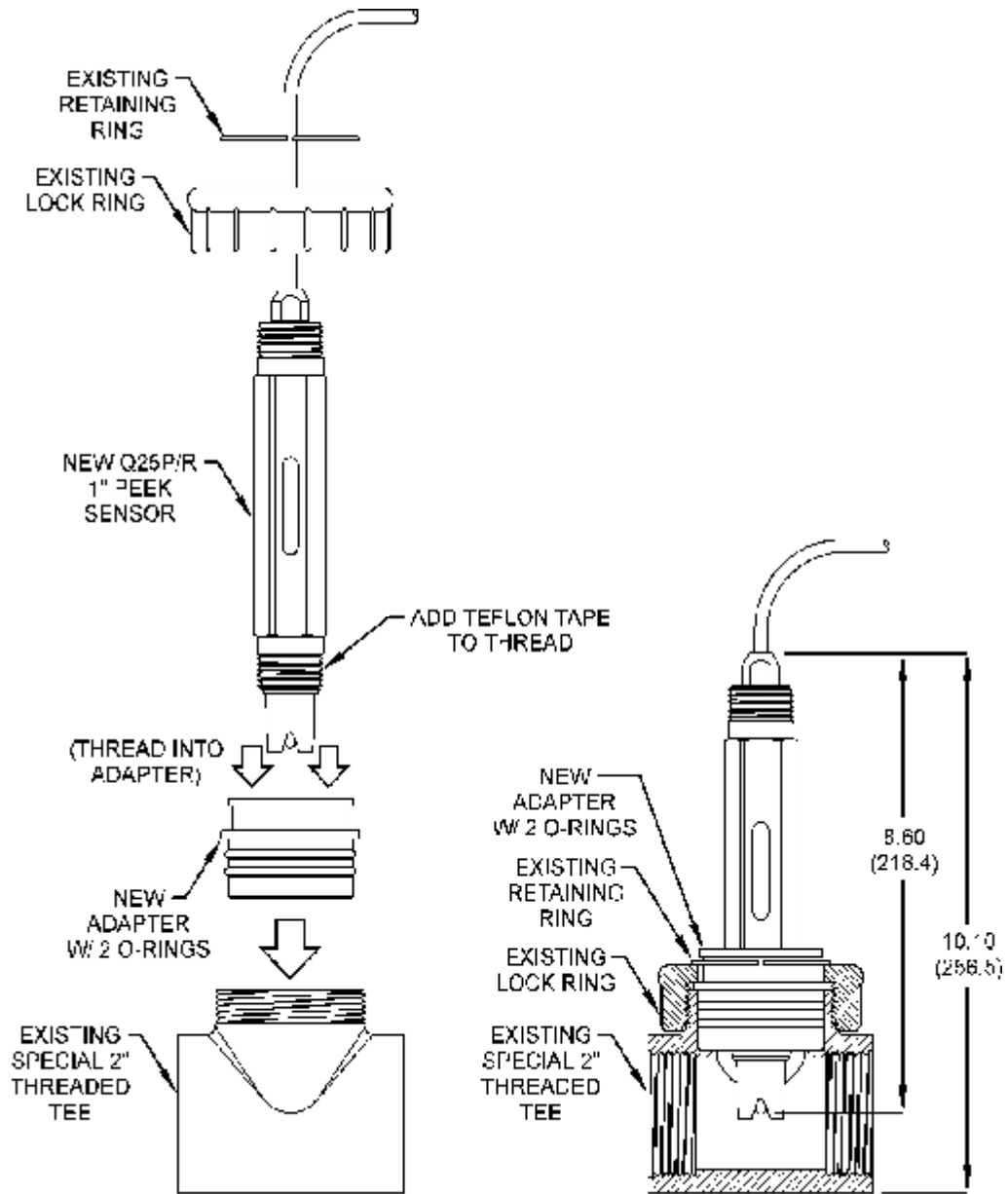
### 3.3 Union Mounting

For mounting the sensor in larger pipe and allowing for easy sensor removal, a 1 1/2" of 2" union mount adapter system is available. This arrangement allows connection of the sensor to pipe sizes up to 2 inches (using adapters if necessary) while allowing easy removal without twisting sensor wires. Contact ATI for part numbers and prices for union mount assemblies and associated pipe tees.



**Figure 7 - 1.5" Union Mount**

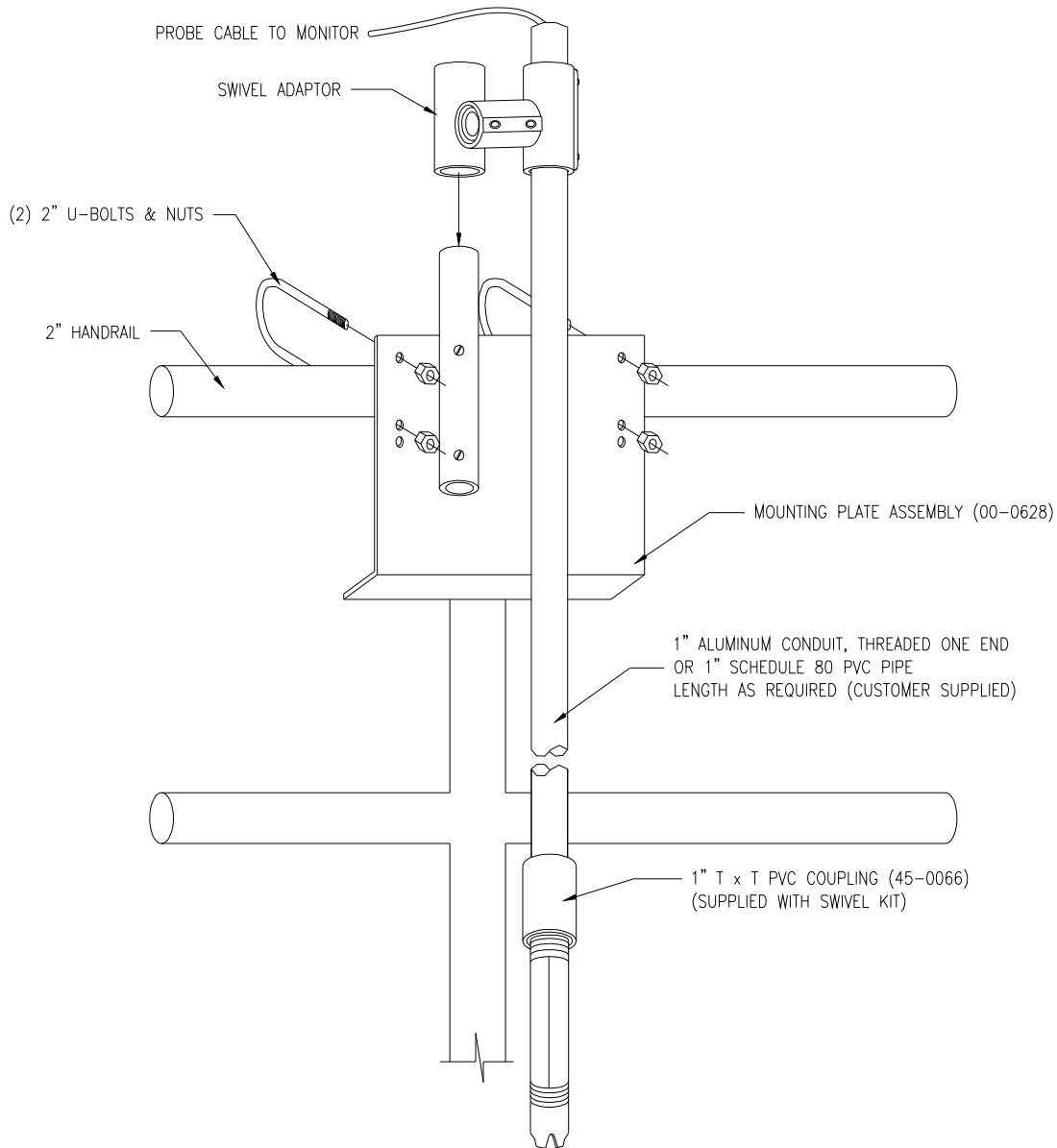




**Figure 8 - 2" Union Mount**

### 3.5 Submersion Mounting

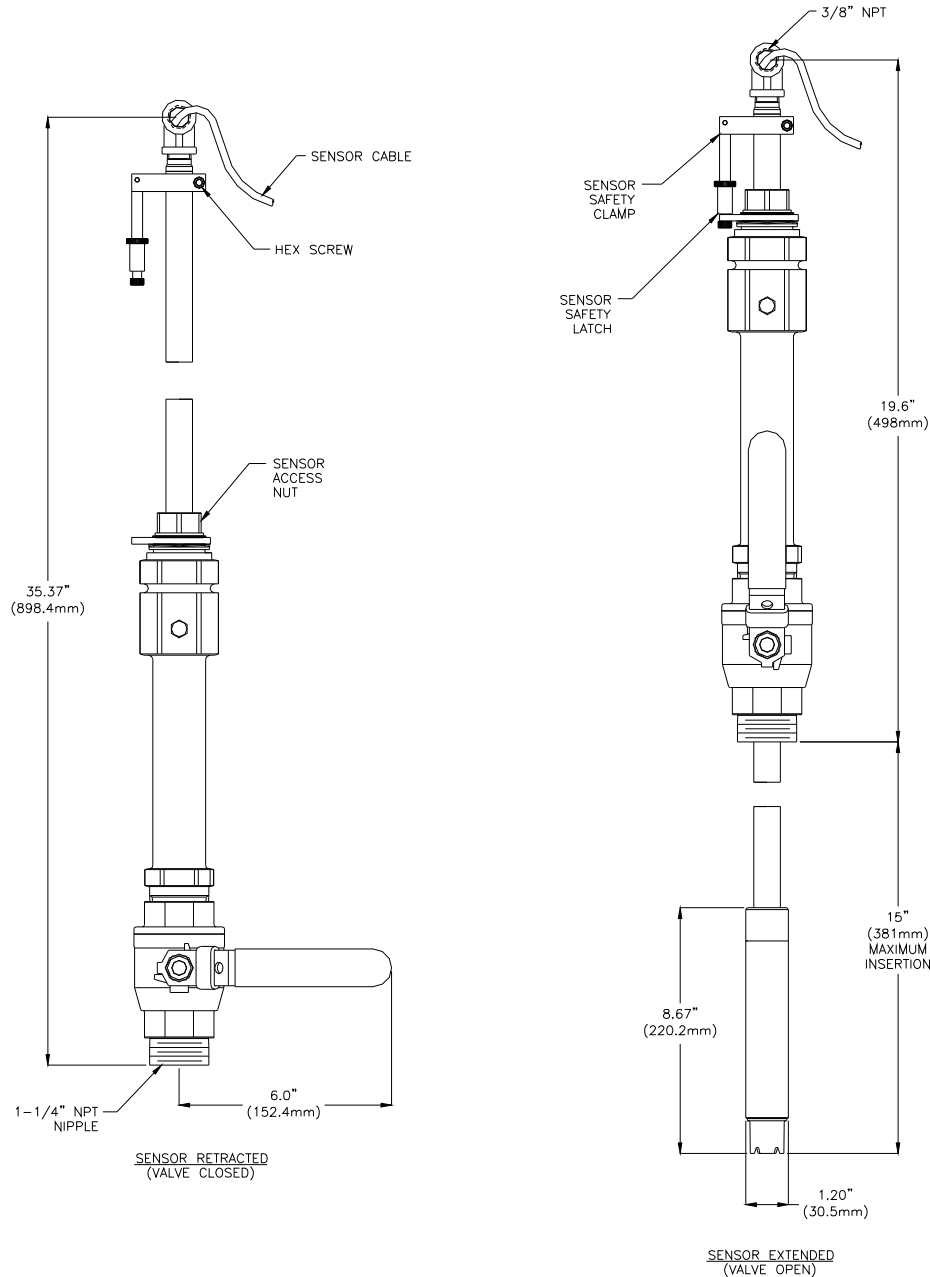
When using this sensor for submersion applications, mount the sensor to the end of a 1" mounting pipe using a 1" coupling. ATI's (00-0628) mounting assembly shown in Figure 9 is available for submersible applications. This assembly is designed to mount to standard handrails and facilitates insertion and removal of the sensor.



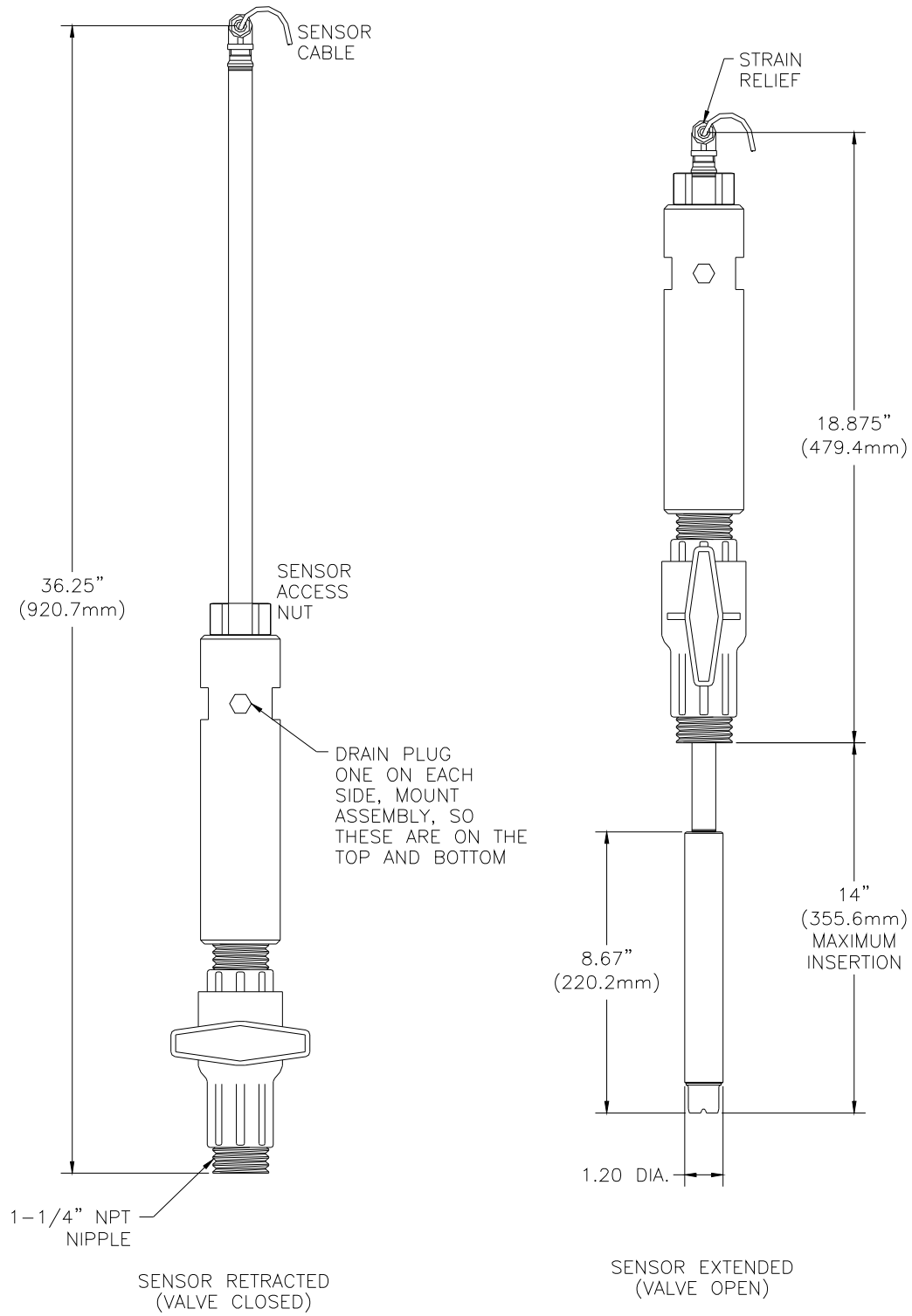
**Figure 9 - Sensor Submersion Mount**

### 3.6 Insertion Mounting

Special insertion mounting hardware is available for applications requiring the removal of the sensor from a process line or tank without shutting off the sample flow in the line. Figure 10 & Figure 11 show typical insertion assemblies. Separate manuals are available for the installation and operation of these assemblies.



**Figure 10 - S.S. Sensor Insertion Mount**



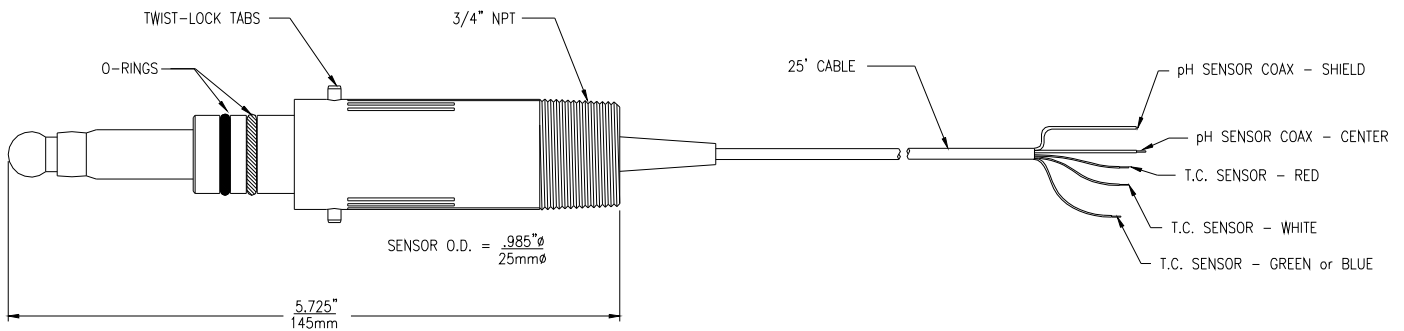
**Figure 11 - CPVC Sensor Insertion Mount**

### 3.7 Conventional pH Sensors

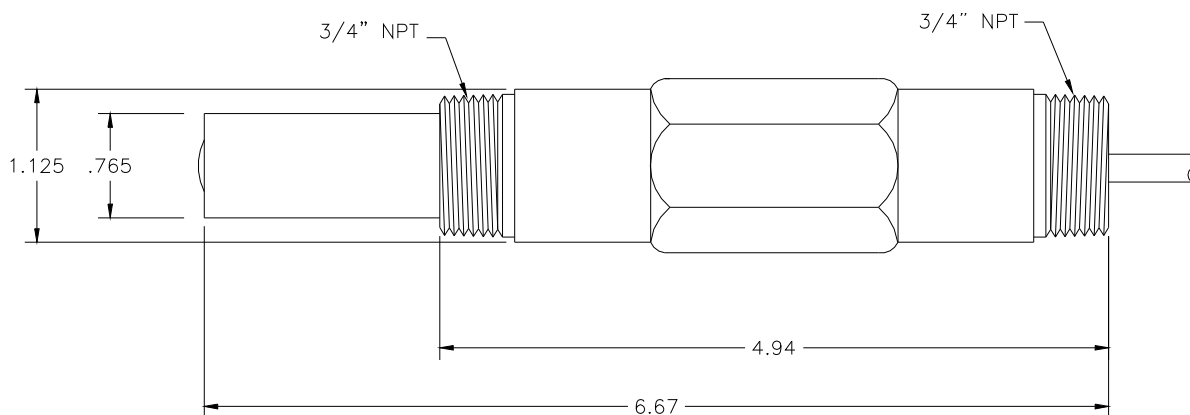
As indicated previously, Model Q45P transmitters may be used with standard combination pH sensors available from a variety of manufacturers. For simple clean water applications, these lower cost sensors may be all that's needed for reliable monitoring. ATI offers a few of these types of sensors as standard items and can assist with the selection of special sensors should the need arise.

Figure 12 and Figure 13 below show the dimensions of two pH sensors frequently used with the Q45P. The 63-0013 sensor is suitable for use with either a pipe tee adapter or a special clear acrylic sealed flowcell.

The 63-0009 pH sensor with flat glass tip is suitable for submersion use, or for screwing directly into a pipe tee. If using in a tee, be careful to allow for enough slack cable so that the cable does not twist excessively.



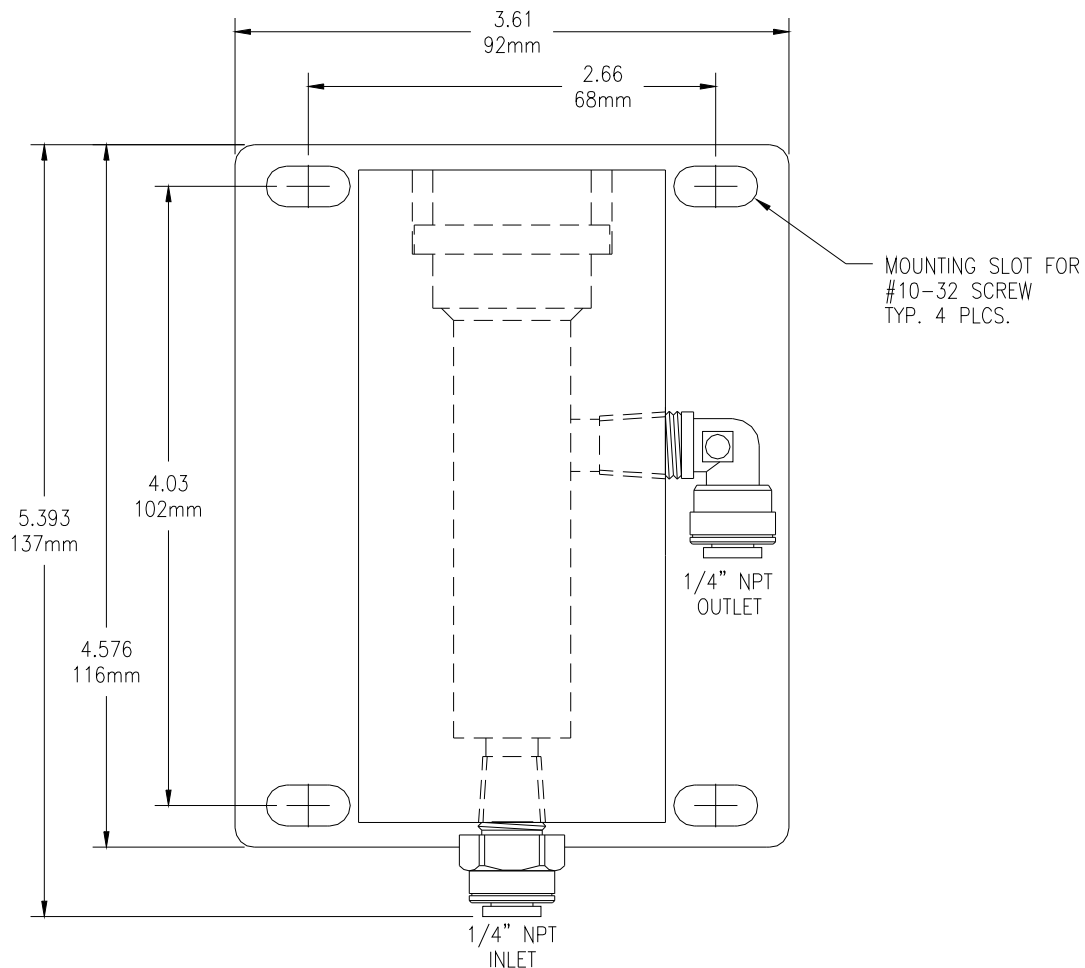
**Figure 12 - (63-0013) Combination pH Sensor, Flow Type**



**Figure 13 - (63-0009) Combination pH Sensor, Sub. Type**

### 3.71 Sealed Flowcell

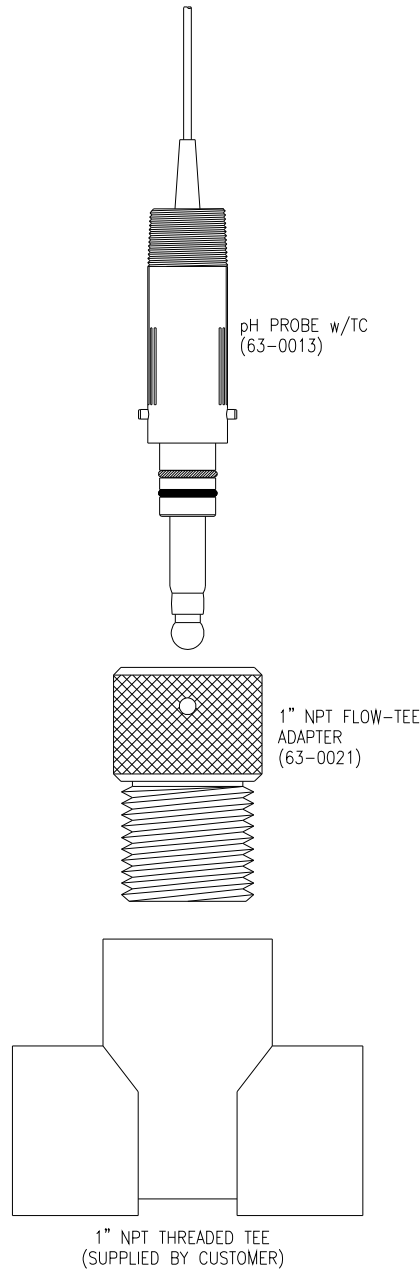
For applications where a flowcell is desired, a sealed flowcell (00-1527) shown in Figure 14 is available. This flowcell is used only with sensor (63-0005) or (63-0013) and may be used for sample pressures up to 75 PSIG. The sample flow should be controlled to 300-800 cc/min. When using this flowcell for pH measurement, put the flow control valve **AFTER** the flowcell. This will maintain sample pressure through the flowcell and avoid “degassing” of the sample. Degassing can lead to bubbles on the end of the sensor which will cause erratic readings. **If degassing cannot be avoided, mount the flowcell horizontally with the inlet on the side and the outlet on the top so that air bubbles naturally flow away from the sensor tip.**



**Figure 14 - Sealed Flowcell Details**

**3.72 Flow Tee Adapter**

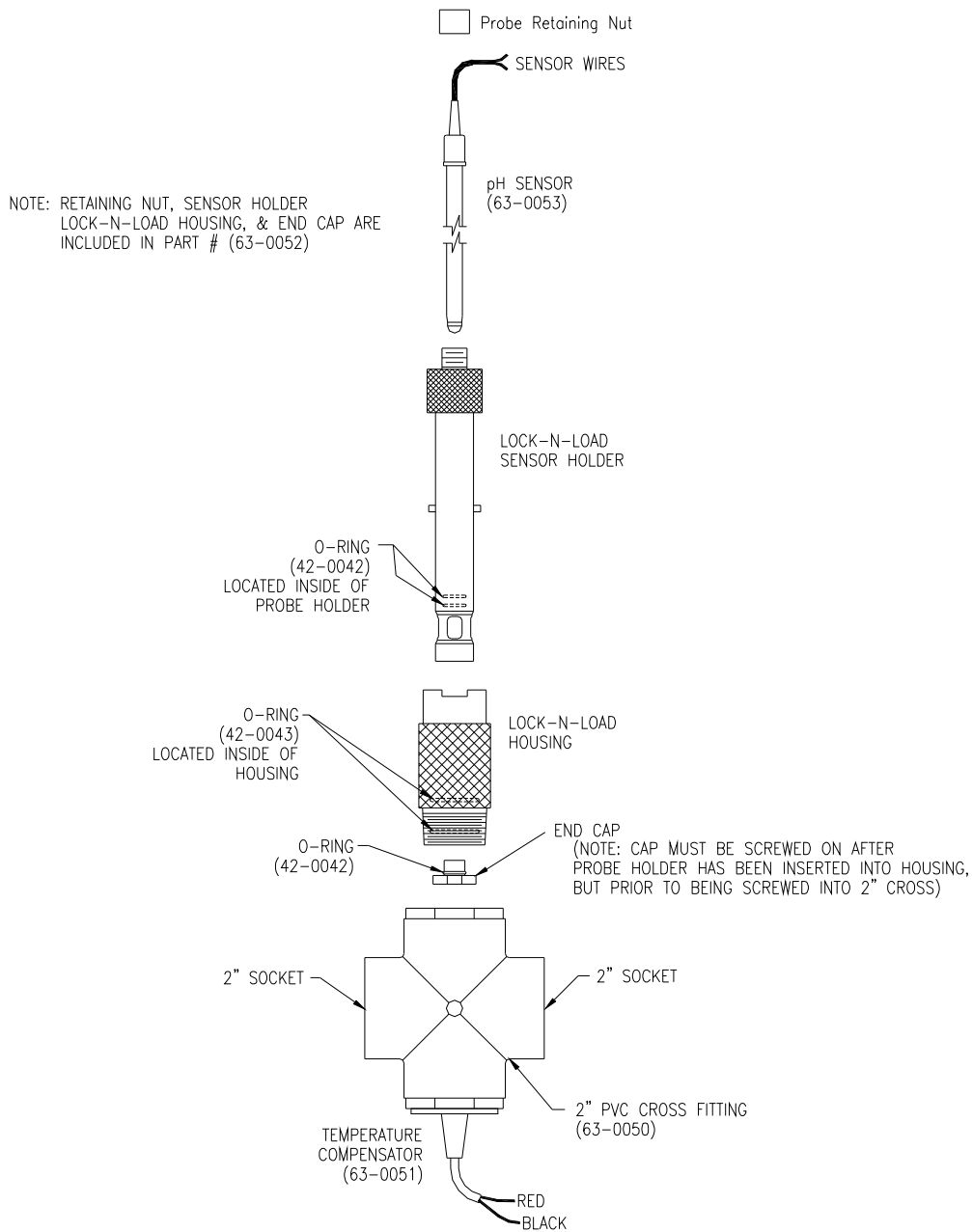
When using the 63-0013 sensor in a flow application, a 1" or 3/4" pipe tee adapter is required. Figure 15 shows a detail of that arrangement.



**Figure 15 - Twist-Lock Flow Tee**

### 3.8 Lock-n-Load System

A special sensor/flowcell system is available that allows insertion and removal of a pH sensor under flow conditions. Called a Lock-n-Load system, this assembly uses a 2" flow tee and special sensor holder that retracts the sensor from a flowing sample for maintenance and cleaning. It is simpler than an insertion assembly and is very useful in lower pressure and clean water applications.



**Figure 16 - Lock-n-Load Sensor Exploded View**



## Part 4 – Electrical Installation

---

### 4.1 General

The Q45 5-17 VDC Externally Powered Transmitter is designed for low power operation for solar power applications. Please verify the type of unit before connecting any power.



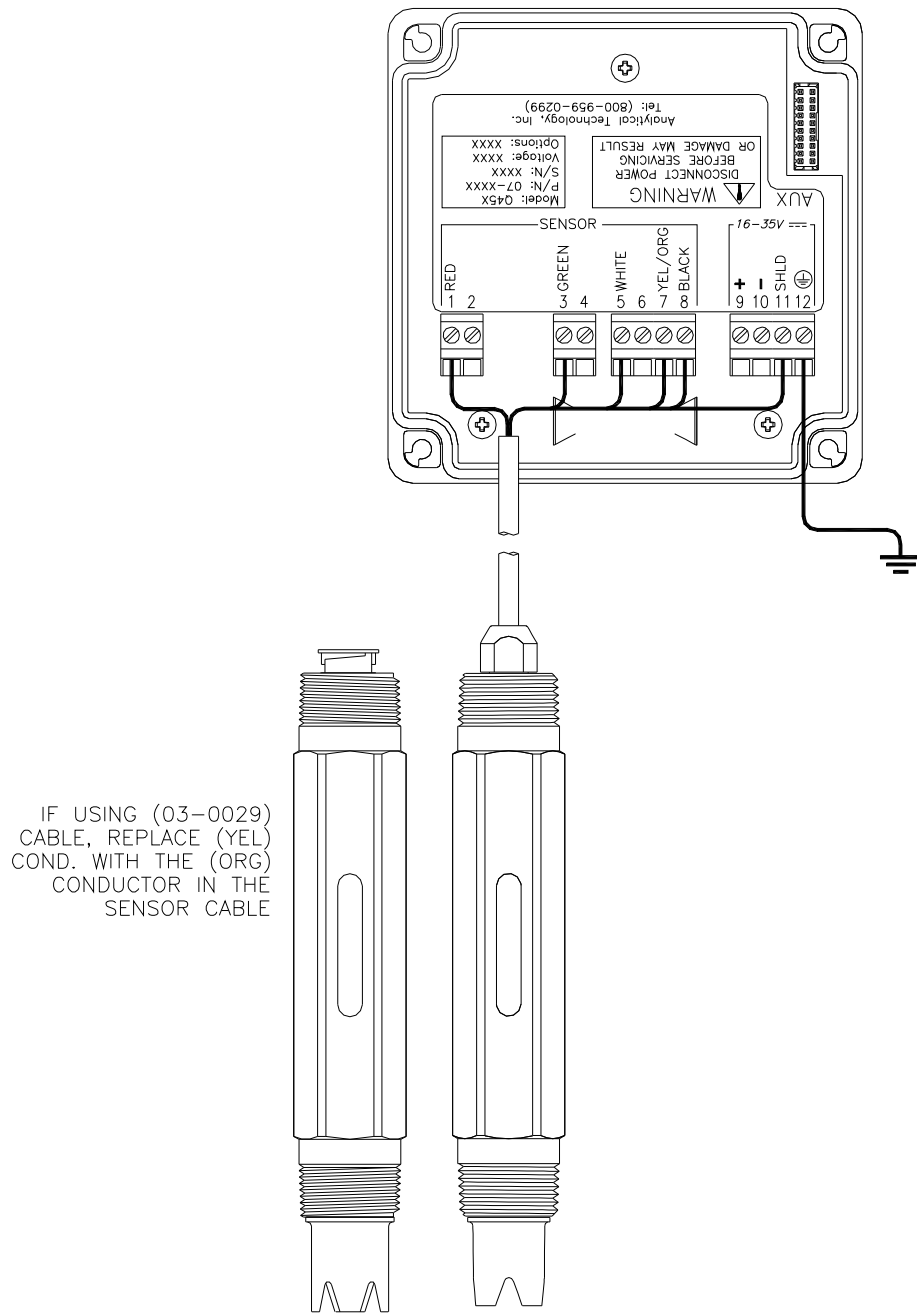
**WARNING: Do not connect AC line power to the PCB module. Severe damage will result.**

#### Important Notes:

1. Use wiring practices that conform to all national, state and local electrical codes. For proper safety as well as stable measuring performance, it is important that the earth ground connection be made to a solid ground point from earth terminal 12 as shown in Figure 17.
2. Do NOT run sensor cables or instrument output wiring in the same conduit that contains AC power wiring. AC power wiring should be run in a dedicated conduit to prevent electrical noise from coupling with the instrumentation signals.
3. This analyzer must be installed by specifically trained personnel in accordance with relevant local codes and instructions contained in this operating manual. Observe the analyzer's technical specifications and input ratings.

### 4.2 External Power

Q45P units ordered with the external connection option are designed for applications where power is to be supplied from an external source, and the two voltage outputs are to be wired to an external device. Figure 18 identifies the terminal connections for external powers.



**Figure 17 - DC/Loop Power Wiring Diagram**

**Note:** Earth ground into Terminal 12 is **STRONGLY** recommended. This connection can greatly improve stability in electrically noisy environments.

The external power board contains 3 switch assemblies as shown in the drawings.

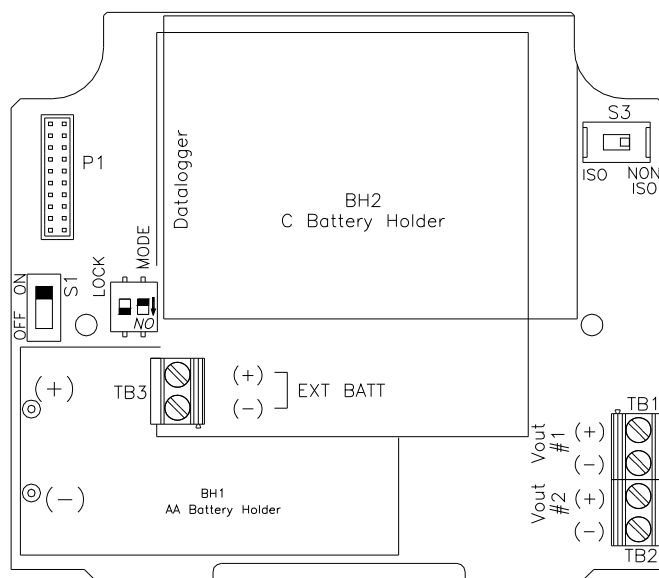
The first (**S1**) is an On/Off slide switch. This switch must be in the ON position for operation. Turn it to OFF if you do not intend to operate the monitor in the next week or two.

The second switch assembly (**S2**) contains two switches, the one on the left marked LOCK and the one on the right marked MODE. The function of these two slide switches are as follow:

**LOCK** This switch is used to define how the monitor will turn on and off. This switch is normally in the OFF position. With the lock switch off, the monitor will be turned on manually using the MENU key on the front of the monitor. With the lock switch in the ON position, the monitor will always be on when there is enough power to run the monitor. The ON position is normally used when operating from an external power supply intended for continuous operation.

**MODE** This switch reserved for Battery Powered Operation. **(No Function when used with External Power Transmitter)**

The third switch assembly is a single slide switch (**S3**) which defines whether the 0-2.5 VDC signals from the monitor are isolated or non-isolated. Output isolation is not required when outputs are connected to a data logging device. However, if the outputs are connected to external devices, putting this switch in the ISO position will protect against possible ground loops. The isolation circuit will slightly increase the power requirement of the monitor.



**Figure 18 - External Power Board**

### 4.3 Voltage Outputs

There are two sets of analog voltage outputs on the board that may be used to send isolated data back to remotely located recorders, PLC's, etc. Output #1 is used only for pH, and Output #2 can be used for either °C/°F or pH.

### 4.4 Sensor Wiring

The sensor cable can be quickly connected to the Q45 terminal strip by matching the wire colors on the cable to the color designations on the label in the monitor. A junction box is also available to provide a break point for long sensor cable runs. Route signal cable away from AC power lines, adjustable frequency drives, motors, or other noisy electrical signal lines. Do not run sensor or signal cables in conduit that contains AC power lines or motor leads.

Standard convertible sensors, insertion sensors, and sanitary sensors have cable permanently attached to the sensor. This cable contains double shielded conductors to minimize noise problems in heavy industrial environments. Convertible sensors with connectors and flow type sensors use a slightly different cable assembly with only a single shield. This assembly is sufficient for many applications where EMI/RFI problems are not severe. Figure 19 and Figure 20 show the two different cable assembly terminations.

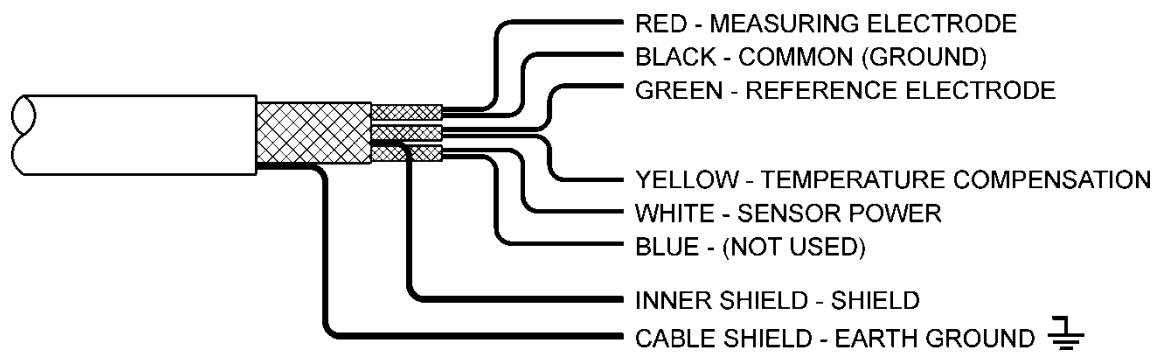


Figure 19 - Cable Description, Model Q25P

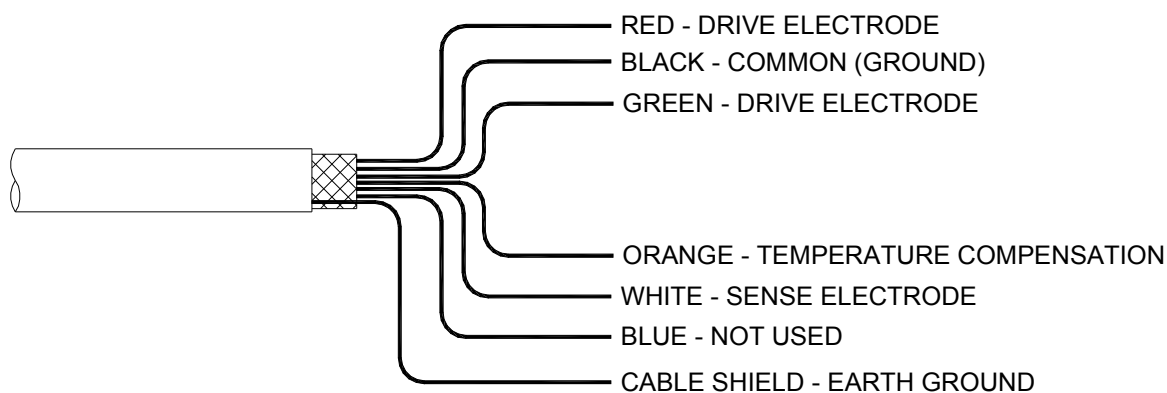


Figure 20 - Detachable Single Shielded Cable, Model Q25P



**DANGER: DO NOT connect sensor cable to power lines. Serious injury may result.**

Take care to route sensor cable away from AC power lines, adjustable frequency drives, motors, or other noisy electrical signal lines. Do not run signal lines in the same conduit as AC power lines. Run signal cable in dedicated metal conduit if possible. For optimum electrical noise protection, run an earth ground wire to the ground terminal in the transmitter.

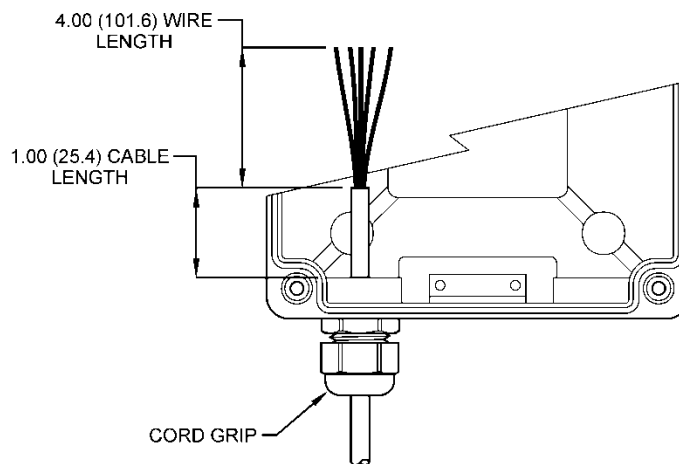


Only ATi's custom 6-wire shielded interconnect cable should be used when connecting the Model Q25P sensor to the analyzer. This high-performance, double shielded, polyethylene jacketed cable is specially designed to provide the proper signal shielding for the sensor used in this system. Substituted cables may cause problems with system performance

#### 4.5 Direct Sensor Connection

Sensor connections are made in accordance with Figure 21. The sensor cable can be routed into the enclosure through one of cord-grips supplied with the unit. Routing sensor wiring through conduit is only recommended if a junction box is to be used. Some loose cable is needed near the installation point so that the sensor can be inserted and removed easily from the flowcell.

Cord-grips used for sealing the cable should be snugly tightened after electrical connections have been made to prevent moisture incursion. When stripping cables, leave adequate length for connections in the transmitter enclosure as shown below. The standard 15 ft. sensor cable normally supplied with the system is already stripped and ready for wiring. This cable can be cut to a shorter length if desired to remove extra cable in a given installation. Do not cut the cable so short as to make installation and removal of the sensor difficult.

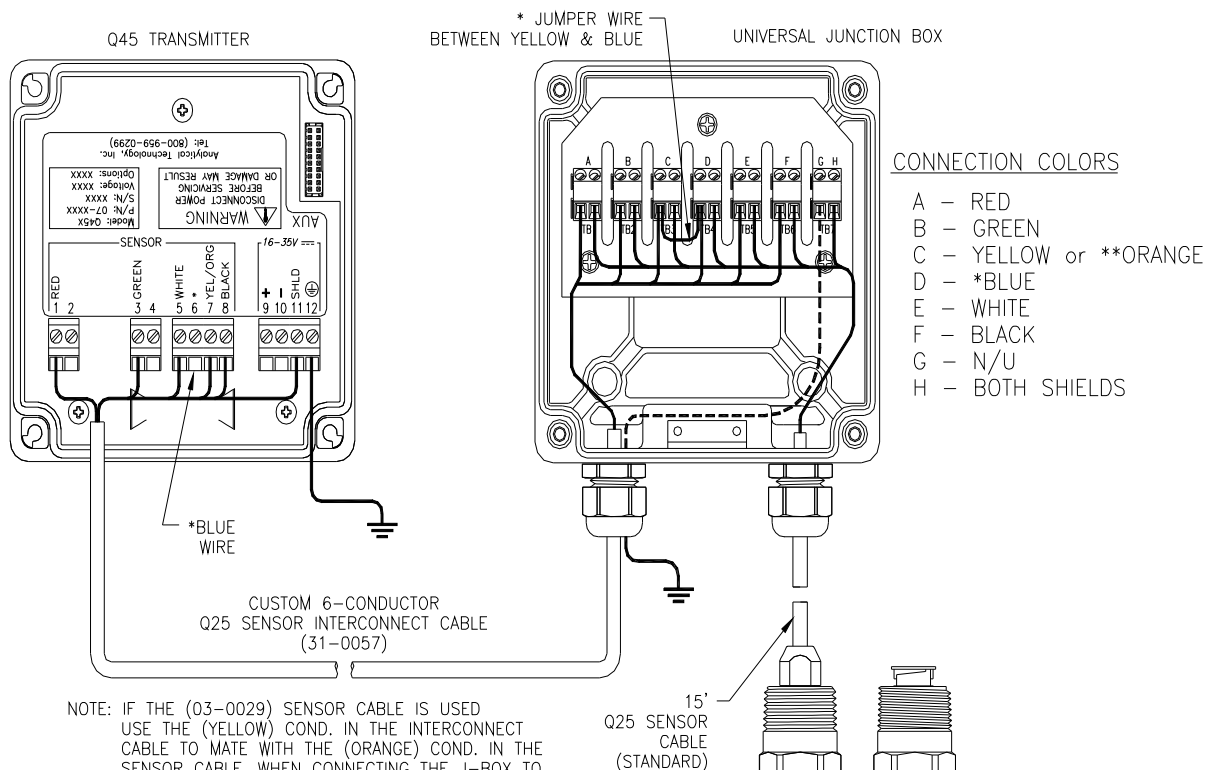


**Figure 21 - Sensor Cable Preparation**

Once inside the enclosure, the individual colored sensor cable leads can be connected directly to the SENSOR connection terminals by matching the wire colors. On Q45P older systems, there may exist a YELLOW wire label on the sensor terminal strip rather than the wire color ORANGE or BROWN, which are used now. If your system has a YELLOW label, simply connect orange/brown from the sensor to that point.

### 4.6 Junction Box Connection

For installations where the sensor is to be located more than 30 feet from the monitor (max. 100 feet), a junction box must be used. The junction box is shown in Figure 22, and is supplied with Pg9 gland seals for sensor and interconnect wiring installation.



NOTE: IF THE (03-0029) SENSOR CABLE IS USED USE THE (YELLOW) COND. IN THE INTERCONNECT CABLE TO MATE WITH THE (ORANGE) COND. IN THE SENSOR CABLE, WHEN CONNECTING THE J-BOX TO THE TRANSMITTER.

\* When utilizing the 3-wire RTD connection, a wire jumper must be made between the yellow and blue wires in the junction box as shown. The blue wire on the connecting sensor cable must be attached to Terminal 6 in the Q45 Transmitter as shown. In addition, a jumper on the scaling board must also be removed. See section 4.9 for details listed under the External Temperature Compensation section.

Connecting sensor cable lengths can be up to 400 feet with a 2-wire RTD connection, and up to 3,000 feet with a 3-wire RTD connection.

When utilizing the junction box connection, the blue wire on the connecting sensor cable must be attached to Terminal 6 on the Q45 Transmitter, as above. However, the blue wire on the Q25 Sensor cable is not used.

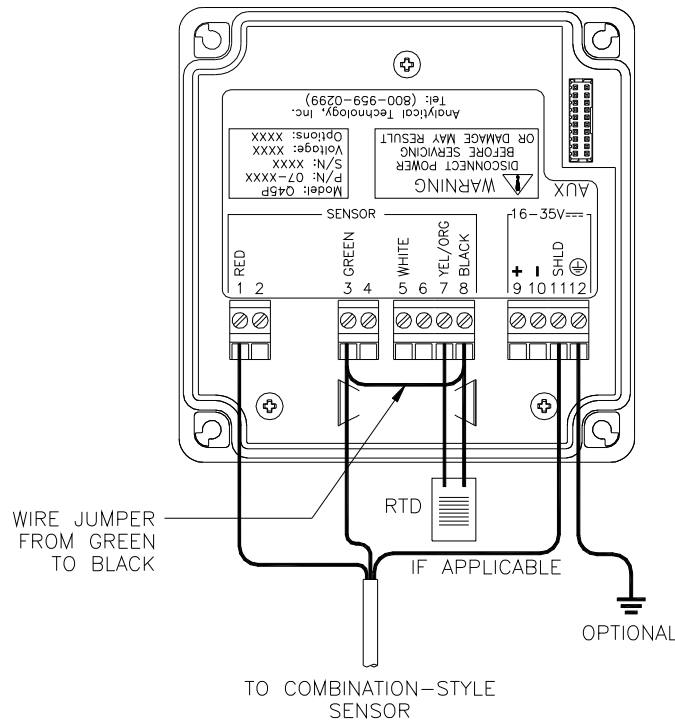
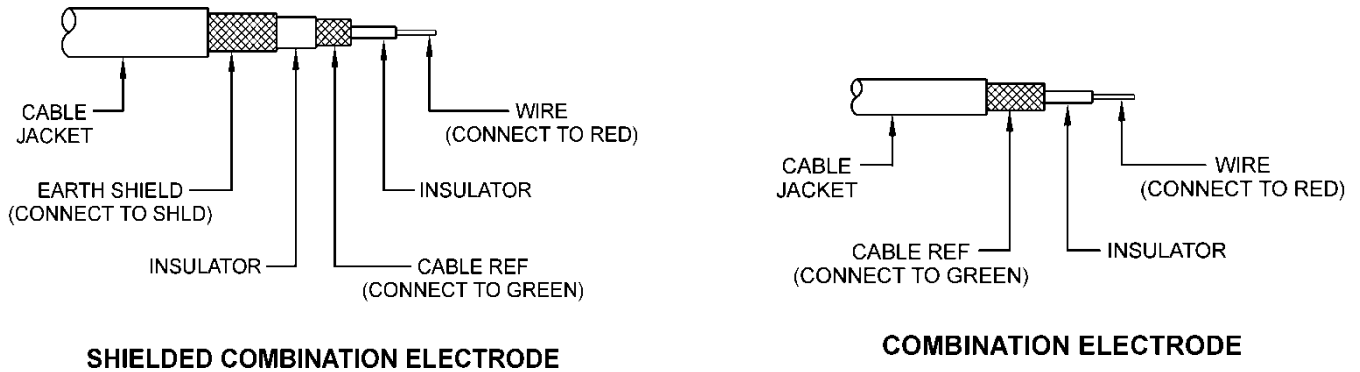
Use ONLY ATI 6-conductor Q25 Sensor interconnect cable between the transmitter and the junction box.

\*\* (ORANGE) CONDUCTOR REPLACES THE YELLOW CONDUCTOR IF USING THE (03-0029) CABLE

**Figure 22 - Junction Box Interconnect Wiring**

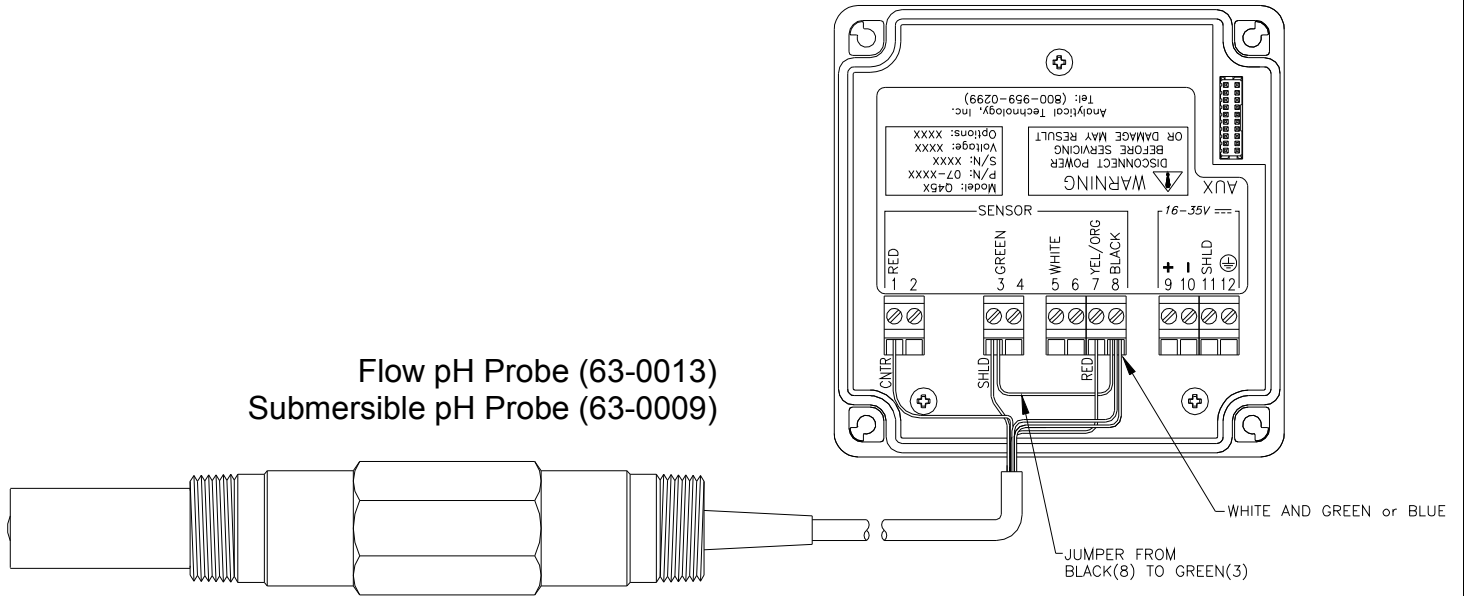
### 4.7 Combination Electrode Connection

The Q45P may also be used with non-amplified simple combination electrodes (see Figure 23). Note that a wire jumper must be installed from Terminal 3 to Terminal 8. The user must also select Sensor Type 2 within the Config Menu (see Section 5.24). The maximum sensor-to-instrument cable length will be severely limited (30-50 feet) with electrodes of this type. The length will depend on the specific electrode impedance and the quality of interconnect cable provided by the manufacturer.



**Figure 23 - Sensor Connections, Combination Electrodes**





Flow pH Probe (63-0013)  
Submersible pH Probe (63-0009)

For other combination Electrodes, connect as follows:

- Terminal 1- Glass Electrode
- 3 - Reference Electrode
- 7 - PT100 or PT1000 Temp. Element
- 8 - PT100 or PT1000 Temp Element

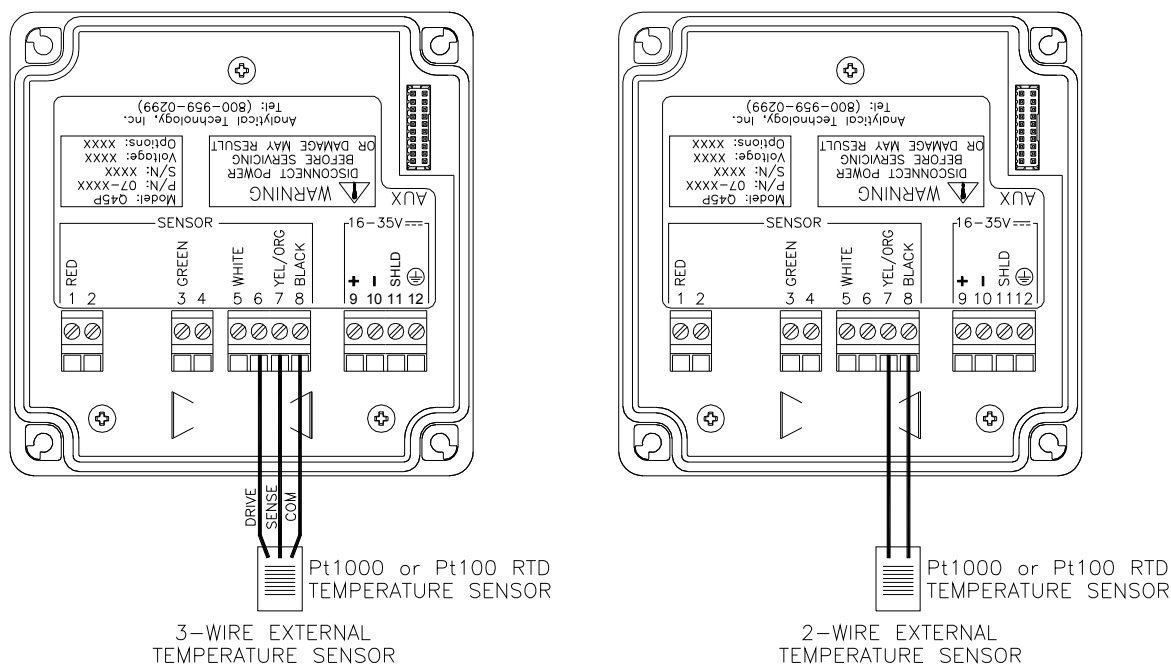
NOTES: 1. Terminals 3 and 8 **MUST** be connected with jumper wire.

**Figure 24 - Combination Electrode Connections**

### 4.7 External Temperature Compensation

All Q25P sensors include an integral Pt1000 RTD. The Q45 series instruments also allow user-supplied external Pt1000 or Pt100 elements to be connected to the temperature input, as shown in Figure 25. Note that when using the Pt100 connection, sensor cable length will be limited to 40 feet due to the high cable resistance error associated with the lower resistance output of Pt100 RTD elements. Cable resistance represents a higher percentage of error signal when using a lower-resistance RTD.

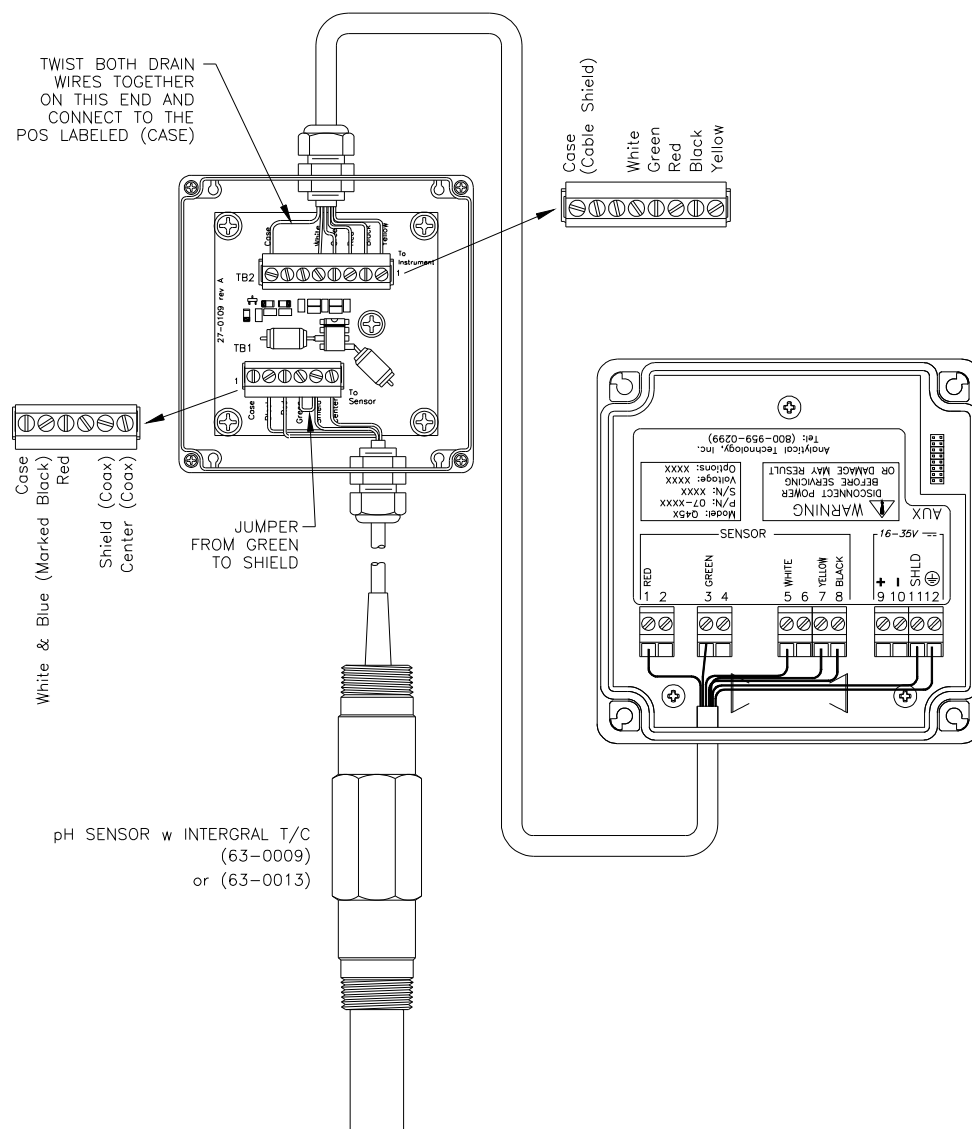
For sensor cable distances of 400 feet or more, a three-wire RTD connection will produce the highest accuracy measurement. This connection requires the use of a junction box. To configure the instrument for a three-wire connection, the metal PCB shield over the terminal strips must be carefully removed by first removing the three retaining screws, then gently prying the shield upward and slightly pushing the terminal strips through the opening in the shield. Once the shield has been removed, the user must cut a small white jumper J1 in the lower-right section of the top scaling board. Replace the shield and connect the pH sensor. If the two-wire connection is desired at any time after this change has been made, the user must install a wire jumper between terminals 6 and 7 on the transmitter.



**Figure 25 - External Temperature Compensation**

### 4.8 External Preamplifier

An external preamplifier is available which allows the use of conventional pH sensors long distances from the Q45P electronics. This preamp is housed in a Nema 4X enclosure and must be located within 25 ft. of the pH sensor. It is critical that any conduit entry installed in this enclosure be completely sealed. Moisture entering the enclosure through a conduit will cause failure of the amplifier circuit. Use of this preamp allows the Q45P to be located up to 300 metres from the sensor/preamp installation location. Wiring for that system is shown below.

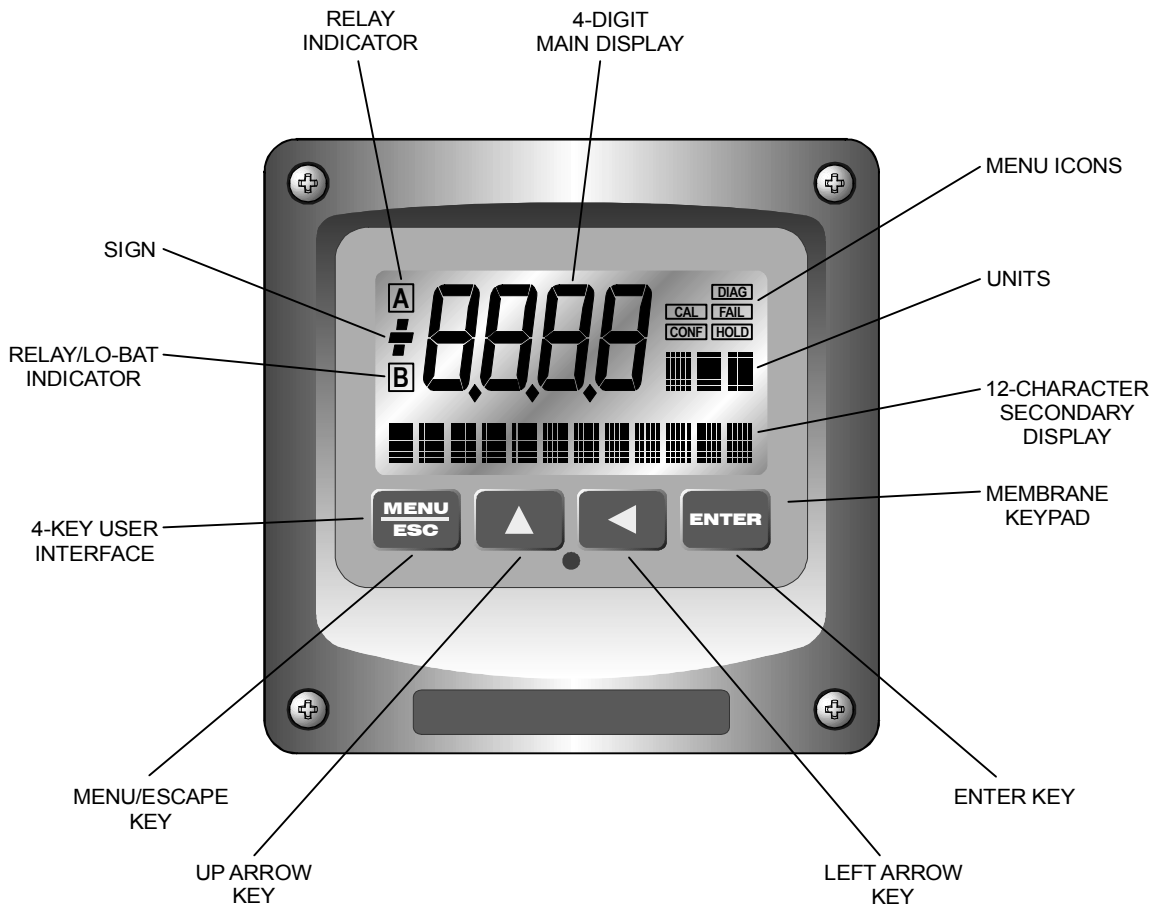


**Figure 26 - External Preamplifier for Conventional Sensor Wiring**

# Part 5 – Configuration

## 5.1 User Interface

The user interface for the Q45 Series instrument consists of a custom display and a membrane keypad. All functions are accessed from this user interface (no internal jumpers, pots, etc.).



**Figure 27 - User Interface**

### 5.11 Keys

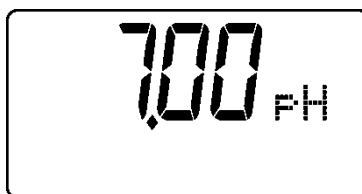
All user configurations occur through the use of four membrane keys. These keys are used as follows:

- |                     |  |
|---------------------|--|
| <b>MENU/ESC</b>     | To scroll through the menu section headers or to escape from anywhere in software. The escape sequence allows the user to back out of any changes in a logical manner. Using the escape key aborts all changes to the current screen and backs the user out one level in the software tree. The manual will refer to this key as either MENU or ESC, depending upon its particular function. |
| <b>UP (arrow)</b>   | To scroll through individual list or display items and to change number values.  |
| <b>LEFT (arrow)</b> | To move the cursor from right to left during changes to a number value.  |
| <b>ENTER</b>        | To select a menu section or list item for change and to store any change.  |

### 5.12 Display

The large custom display provides clear information for general measurement use and user configuration. There are three main areas of the display: the main parameter display, the secondary message line, and the icon area.

- |                       |  |
|-----------------------|--|
| <b>Main Parameter</b> | During normal operation, the main parameter display indicates the present process input with sign and units. This main display may be configured to display any of the main measurements that the system provides. During configuration, this area displays other useful set-up information to the user. |
|-----------------------|--|



**Lower Line**

During normal operation, the lower line of the display indicates user-selected secondary measurements that the system is making. This also includes calibration data from the last calibration sequence and the transmitter model number and software version. During configuration, the lower line displays menu items and set-up prompts to the user. Finally, the lower line will display error messages when necessary. For a description of all display messages, refer to Section 7.3.

**Icon Area**

The icon area contains display icons that assist the user in set-up and indicate important states of system functions. The CAL, CONFIG, and DIAG icons are used to tell the user what branch of the software tree the user is in while scrolling through the menu items. This improves software map navigation dramatically. Upon entry into a menu, the title is displayed (such as CAL), and then the title disappears to make way for the actual menu item. However, the icon stays on.

**HOLD**

The HOLD icon indicates that the current output of the transmitter has been put into output hold. In this case, the output is locked to the last input value measured when the HOLD function was entered. HOLD values are retained even if the unit power is cycled.

**FAIL**

The FAIL icon indicates that the system diagnostic function has detected a problem that requires immediate attention. This icon is automatically cleared once the problem has been resolved.

## 5.2 Software

The software of the Q45P is organized in an easy to follow menu-based system. All user settings are organized under five menu sections: Measure, Calibration [CAL], Configuration [CONFIG], Control [CONTROL] and Diagnostics [DIAG].

**Note: The default Measure Menu is display-only and has no menu icon.**

### 5.2.1 Software Navigation

Within the CAL, CONFIG, CONTROL, and DIAG menu sections is a list of selectable items. Once a menu section (such as CONFIG) has been selected with the MENU key, the user can access the item list in this section by pressing either the ENTER key or the UP arrow key. The list items can then be scrolled through using the UP arrow key. Once the last item is reached, the list wraps around and the first list item is shown again. The items in the menu sections are organized such that more frequently used functions are first, while more permanent function settings are later in the list. See Figure 28 for a visual description of the software.

Each list item allows a change to a stored system variable. List items are designed in one of two forms: simple single variable, or multiple variable sequence. In the single variable format, the user can quickly modify one parameter - for example, changing temperature display units from °F to °C. In the multiple variable sequence, variables are changed as the result of some process. For example, the calibration of pH generally requires more than one piece of information to be entered. The majority of the menu items in the software consist of the single variable format type.

Any data that may be changed will be flashing. This flashing indicates user entry mode and is initiated by pressing the ENTER key. The UP arrow key will increase a flashing digit from 0 to 9. The LEFT arrow key moves the flashing digit from right to left. Once the change has been completed, pressing ENTER again stores the variable and stops the flashing. Pressing ESC aborts the change and also exits user entry mode.

The starting (default) screen is always the Measure Menu. The UP arrow key is used to select the desired display. From anywhere in this section the user can press the MENU key to select one of the four Menu Sections.

The UP arrow icon next to all list items on the display is a reminder to scroll through the list using the UP arrow key.

To select a list item for modification, first select the proper menu with the MENU key. Scroll to the list item with the UP arrow key and then press the ENTER key. This tells the system that the user wishes to perform a change on that item. For single item type screens, once the user presses the ENTER key, part or all of the variable will begin to flash, indicating that the user may modify that variable using the arrow keys. However, if the instrument is locked, the transmitter will display the message **Locked!** and will not enter user entry mode. The instrument must be unlocked by entering the proper code value to allow authorized changes to user entered values. Once the variable has been reset, pressing the ENTER key again causes the change to be stored and the flashing to stop. The message **Accepted!** will be displayed if the change is within pre-defined variable limits. If the user decides not to modify the value after it has already been partially changed, pressing the ESC key aborts the modification and returns the entry to its original stored value.

In a menu item which is a multiple variable sequence type, once the ENTER key is pressed there may be several prompts and sequences that are run to complete the modification. The ESC key can always be used to abort the sequence without changing any stored variables.



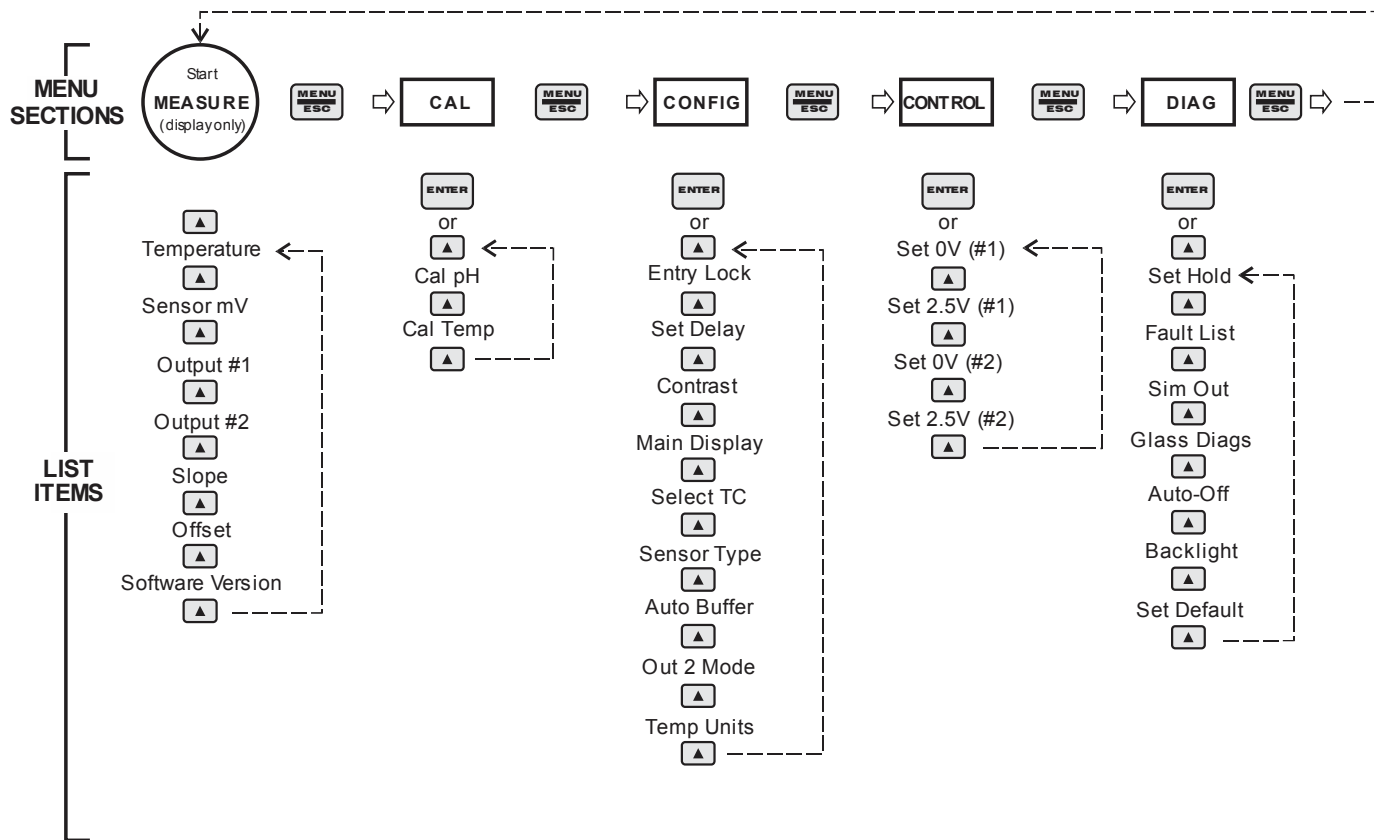


Figure 28 - Software Map

## 5.22 Measure Menu [MEASURE]

The default menu for the system is the display-only menu MEASURE. This menu is a display-only measurement menu, and has no changeable list items. When left alone, the instrument will automatically return to this menu after approximately 30 minutes. While in the default menu, the UP arrow allows the user to scroll through the secondary variables on the lower line of the display. A brief description of the fields in the basic transmitter version is as follows:

### TRANSMITTER MEAS SCREENS:

<b>25.7°</b>	Temperature display. Can be displayed in °C or °F, depending on user selection. A small “m” on the left side of the screen indicates the transmitter has automatically jumped to a manual 25°C setting due to a failure with the temperature signal input.
<b>+132 mV</b>	Raw sensor voltage. Useful for diagnosing problems.
<b>#1 0.00 VDC</b>	Instrument output signal #1.
<b>#2 1.25 VDC</b>	Instrument output signal #2.
<b>Slope = 100%</b>	Sensor output response vs. ideal calibration. This value updates after each calibration. As the sensor ages, the slope reading will decay indicating sensor aging. Useful for resolving sensor problems.
<b>Offset = 0.0 mV</b>	Sensor output current at a zero ppm input. This value updates after a zero-calibration has been performed. Useful for resolving sensor problems.
<b>Q45P v4.01</b>	Transmitter software version number.

**Note: A display test (all segments ON) can be actuated by pressing and holding the ENTER key while viewing the model/version number on the lower line of the display.**

The MEASURE screens are intended to be used as a very quick means of looking up critical values during operation or troubleshooting.

### 5.23 Calibration Menu [CAL]

The calibration menu contains items for frequent calibration of user parameters. There are two items in this list: Cal pH, Cal Temp.

**Cal pH**                      The pH calibration function allows the user to adjust the transmitter offset and span reading to match reference buffers, or to adjust the sensor offset to match the sample reading. See Part 6 - Calibration for more details.

**Cal Temp**                    The temperature calibration function allows the user to adjust the offset of the temperature response by a small factor of  $\pm 5$  °C. The temperature input is factory calibrated to very high accuracy. However, long cable lengths and junction boxes may degrade the accuracy of the temperature measurement in some extreme situations. Therefore, this feature is provided as an adjustment. See Part 6 - Calibration for more details.

## 5.24 Configuration Menu [CONFIG]

The Configuration Menu contains all of the general user settings:

### Entry Lock

This function allows the user to lock out unauthorized tampering with instrument settings. All settings may be viewed while the instrument is locked, but they cannot be modified. The Entry Lock feature is a toggle-type setting; that is, entering the correct code will lock the transmitter and entering the correct code again will unlock it. The code is preset at a fixed value. Press ENTER to initiate user entry mode and the first digit will flash. Use arrow keys to modify value. **See the last page of this manual for the Q45P lock/unlock code.** Press ENTER to toggle lock setting once code is correct. Incorrect codes do not change state of lock condition.

### Set Delay

The delay function sets the amount of damping on the instrument. This function allows the user to apply a first order time delay function to the pH measurements being made. Both the display and the output value are affected by the degree of damping. Functions such as calibration are not affected by this parameter. The calibration routines contain their own filtering and stability monitoring functions to minimize the calibration timing. Press ENTER to initiate user entry mode, and the value will flash. Use the arrow keys to modify value; range is 0.1 to 9.9 minutes. Press ENTER to store the new value.

### Contrast

This function sets the contrast level for the display. The custom display is designed with a wide temperature range, Super-Twist Nematic (STN) fluid.

The STN display provides the highest possible contrast and widest viewing angle under all conditions. Contrast control of this type of display is generally not necessary, so contrast control is provided as a means for possible adjustment due to aging at extreme ranges. In addition, the display has an automatic temperature compensation network. Press ENTER to initiate user entry mode, and the value will flash. Use arrow keys to modify the value; range is 0 to 8 (0 being lightest). Press ENTER to update and store the new value.

- Main Display** This function allows the user to change the measurement in the primary display area. The user may select between pH, sensor temperature, or output current. Using this function, the user may choose to put temperature in the main display area and pH on the secondary, lower line of the display. Press ENTER to initiate user entry mode, and the entire value will flash. Use the UP arrow key to modify the desired display value. Press ENTER to store the new value.
- Select TC** This function allows the user to select either a Pt1000 or Pt100 platinum RTD temperature element. The Pt1000 element is the standard element in all high performance Q25 sensors; it is the recommended temperature sensing element for all measurements. The Pt100 selection is provided as an alternative for use with existing combination-style sensors. Press ENTER to initiate user entry mode, and the entire value will flash. Use the UP arrow key to modify the desired value. Press ENTER to store the new value.
- Sensor Type** This function sets the sensor input type. This selection is critical for control of the internal diagnostics and compensation factors. Press ENTER to initiate user entry mode, and the entire value will flash. Use the UP arrow key to modify the desired value. Selections are **1** for Q25P glass sensor, **2** for combination electrode, **3** for Q25P antimony electrode, and **4** for pure water sensor using special compensation table. Press ENTER to store the new value.
- Auto Buffer** This is a multiple variable function that allows the user to choose which pH buffer sets that will be utilized in the 2-point calibration mode. The Q45P contains 3 sets of built-in buffer tables with compensation values ranging from 0 to 95 °C. During 2-point calibration, the instrument will automatically identify which buffer is being used and compensate for the value based on the built-in tables. This allows very quick, highly accurate calibrations by the user. The order in which the buffers are used during calibration is unimportant, since the system automatically chooses the correct buffer.
- The default setting for this feature is **OFF**, which disables the auto-recognition function. Press ENTER to change this setting. The buffer table set options are: 1: [4/7/10], 2: [4/7/9.18], and 3: [4.65/6.79/9.23]. See Figure 29 for buffer tables. Once the buffer set is selected, press ENTER and the message **Accepted!** will be displayed on the lower line.

**Table 1**

4.00 pH		7.00 pH		10.00 pH	
°C	pH	°C	pH	°C	pH
0	4.00	0	7.10	0	10.27
10	3.99	10	7.06	10	10.15
20	4.00	20	7.02	20	10.05
30	4.01	30	6.99	30	9.95
40	4.03	40	6.97	40	9.87
50	4.05	50	6.98	50	9.80
60	4.08	60	6.98	60	9.75
70	4.12	70	6.97	70	9.73
80	4.16	80	6.99	80	9.73
90	4.21	90	7.01	90	9.75
95	4.24	95	7.01	95	9.77

**Table 2**

4.00 pH		7.00 pH		9.18 pH	
°C	pH	°C	pH	°C	pH
0	4.00	0	7.10	0	9.46
10	3.99	10	7.06	10	9.33
20	4.00	20	7.02	20	9.23
30	4.01	30	6.99	30	9.14
40	4.03	40	6.97	40	9.07
50	4.05	50	6.98	50	9.01
60	4.08	60	6.98	60	8.96
70	4.12	70	6.97	70	8.92
80	4.16	80	6.99	80	8.89
90	4.21	90	7.01	90	8.85
95	4.24	95	7.01	95	8.83

**Table 3**

4.65 pH		6.79 pH		9.23 pH	
°C	pH	°C	pH	°C	pH
0	4.67	0	6.89	0	9.48
10	4.66	10	6.84	10	9.37
20	4.65	20	6.80	20	9.27
30	4.65	30	6.78	30	9.18
40	4.66	40	6.76	40	9.09
50	4.68	50	6.76	50	9.00
60	4.70	60	6.76	60	8.92
70	4.72	70	6.76	70	8.88
80	4.75	80	6.78	80	8.85
90	4.79	90	6.80	90	8.82
95	4.79	95	6.80	95	8.82

**Figure 29 - Automatic pH Buffer Tables**

**lout#2 Mode** This function sets analog output #1 to track pH. Press ENTER to initiate user entry mode, and the entire value will flash. Use the UP arrow key to modify the desired value; selections include 1-°C/°F for temperature or 2-pH for pH control. Press ENTER to store the new value.

**Temp Units** This function sets the display units for temperature measurement. Press ENTER to initiate user entry mode, and the entire value will flash. Use the UP arrow key to modify the desired display value. The choices are °F and °C. Press ENTER to store the new value.

## 5.25 Control Menu [CONTROL]

The Control Menu contains all of the output control user settings:

**Set 0V #1**  
**Set 2.5V #1**  
**Set 0V #2**  
**Set 2.5V #2**

These functions set the output range for each of the two instrument outputs. The value stored for the 0V point may be higher or lower than the value stored for the 2.5V point.

The entry values are limited to values within the range selected in the “Set Range” parameter under the CAL Menu and must be separated by at least 1% of this range. Use the LEFT arrow key to select the first digit to be modified. Then use the UP and LEFT arrow keys to select the desired numerical value. Press ENTER to store the new value.

Output #1 will always be in units of ppm, as it is fixed to track pH. Output #2 will be in either units of temperature or PPM, depending on which option is selected for Output #2.

## 5.26 Diagnostics Menu [DIAG]

The diagnostics menu contains all of the user settings that are specific to the system diagnostic functions, as well as functions that aid in troubleshooting application problems.

### Set Hold

The Set Hold function locks the current loop output values on the present process value. This function can be used prior to calibration, or when removing the sensor from the process, to hold the output in a known state. Once HOLD is released, the outputs return to their normal state of following the process input. The transfer out of HOLD is bumpless on the both analog outputs - that is, the transfer occurs in a smooth manner rather than as an abrupt change. An icon on the display indicates the HOLD state, and the HOLD state is retained even if power is cycled. Press ENTER to initiate user entry mode, and entire value will flash. Use the UP arrow key to modify the desired value, selections are **ON** for engaging the HOLD function, and **OFF** to disengage the function. Press ENTER to store the new value.

The Set Hold function can also hold at an output value specified by the user. To customize the hold value, first turn the HOLD function on. Press the ESC key to go to the DIAG Menu and scroll to Sim Output using the UP arrow key. Press ENTER. Follow the instructions under Sim Output (see following page).

### Fault List

The Fault List screen is a read-only screen that allows the user to display the cause of the highest priority failure. The screen indicates the number of faults present in the system and a message detailing the highest priority fault present. Note that some faults can result in multiple displayed failures due to the high number of internal tests occurring. As faults are corrected, they are immediately cleared.

Faults are not stored; therefore, they are immediately removed if power is cycled. If the problem causing the faults still exists, however, faults will be displayed again after power is re-applied and a period of time elapses during which the diagnostic system re-detects them. The exception to this rule is the calibration failure. When a calibration fails, no corrupt data is stored. Therefore, the system continues



to function normally on the data that was present before the calibration was attempted.

After 30 minutes or if power to the transmitter is cycled, the failure for calibration will be cleared until calibration is attempted again. If the problem still exists, the calibration failure will re-occur. Press ENTER to initiate view of the highest priority failure. The display will automatically return to normal after a few seconds.

### Sim Out

The Sim Out function allows the user to simulate the pH level of the instrument in the user selected display range. The user enters a pH value directly onto the screen, and the output responds as if it were actually receiving the signal from the sensor. This allows the user to check the function of attached monitoring equipment during set-up or troubleshooting. Escaping this screen returns the unit to normal operation. Press ENTER to initiate the user entry mode, and the right-most digit of the value will flash. Use arrow keys to modify desired value.

The starting display value will be the last read value of the input. The output will be under control of the SIM screen until the ESC key is pressed.

*Note:* If the HOLD function is engaged before the Sim Output function is engaged, the simulated output will remain the same even when the ESC key is pressed. Disengage the HOLD function to return to normal output.



**NOTE: If the HOLD function is engaged before the Sim Output function is engaged, the simulated output will remain the same even when the ESC key is pressed. Disengage the HOLD function to return to normal output.**

### Glass Diags

This feature not for external powered devices.

### Auto-Off

Enables the automatic shut-off feature for the instrument. If ON, the instrument will automatically shut-off in 60 minutes after no keys are pressed to save power. With the external powered unit, this function should remain at **OFF**.

**Back-Light**

The Back-light screen is used to set the operating conditions under which the backlight will turn on. The default is AUTO, which configures the light to come on whenever any key is pressed. The light will automatically shut off if no key is pressed for 30 seconds. Other selections are OFF (always off), AL for Alarm, where the light comes on in alarm condition and flashes under a Fail condition, and ON (always on).

**Set Default**

The Set Default function allows the user to return the instrument back to factory default data for all user settings. It is intended to be used as a last resort troubleshooting procedure. All user settings are returned to the original factory values. Hidden factory calibration data remains unchanged. Press ENTER to initiate user entry mode and the value **NO** will flash. Use the UP arrow key to modify value to **YES** and press ENTER to reload defaults.

## Part 6 – Calibration

---

### 6.1 Overview and Methods

Since the sensor slope (mV/pH output) will degrade over time, the instrument must be calibrated periodically to maintain a high degree of measurement accuracy. Frequency of calibration must be determined by the application. High temperature applications or applications involving extreme pH operating conditions may require more frequent calibration than those that operate at more neutral pH levels and ambient level temperatures. It is important for the user to establish a periodic cleaning and calibration schedule for sensor maintenance to maintain high system accuracy.

Before calibrating the instrument for the very first time after initial installation, it is important to select the proper operating parameters in the configuration menus for items like Sensor Type and Auto Buffers.

If Auto Buffers is not enabled, select buffers with values that are close to the normal operating pH of the process. For example, if the process is operating normally at 8 pH, buffer values of 9.18 pH and 7.00 pH are preferred over buffers of 4.00 pH and 7.00 pH. If possible, select one of the buffers to be near 7.00 pH.



**NOTE: Buffers must be at least 2 pH units apart to ensure accurate calibration.**

The system provides two methods of pH calibration: 2-point and 1-point. These two methods are significantly different. See Sections 6.13 and 6.14 for a brief description of their uses.

#### 6.11 Sensor Slope

The sensor slope is a number (expressed as a percentage) which represents the current condition of the sensor electrodes. The slope display is updated after every calibration. When new, the sensor slope should be between 95% and 105%. A 100% slope represents an ideal sensor output of 59.16 mV/pH, from standardization (7.00 pH at 25°C). Over time, the glass electrodes in the sensor will age with use. This results in a reduction of the slope (mV/pH output) of the sensor. Thus a sensor slope of 85% is equivalent to an output of 50.29 mV/pH from standardization. The instrument will not allow calibrations on a sensor with a slope less than 80%. The slope information from the most recent calibration can be viewed at any time in the Measure Menu (see Section 5.22).

## 6.12 Sensor Offset

Sensor offset is a number that indicates sensor output (expressed in mV) in 7.00 pH buffer at 25 °C. Ideally, the sensor will output 0 mV under these conditions. A sensor offset reading of +10 mV indicates that the sensor will output +10 mV when placed into a perfect 7.00 pH buffer at 25 °C. In other words, sensor offset shifts the entire mV/pH curve up or down. Sensor offset is generally produced by a small voltage drop at the sensor reference junction. Large offsets are most typically the result of foulants on the reference junction, an aged reference junction, or a weak reference fill solution. The instrument does not allow calibrations on a sensor with an offset greater than +90 mV or less than -90 mV. Sensor offset information from the most recent calibration can be viewed at any time in the Measure Menu (See Section 5.22).

## 6.13 2-Point Calibration Explained

The 2-point calibration method involves the movement of the sensor through two known pH buffer values. Therefore, the sensor must be removed from the application to utilize this method. Two-point calibration adjusts both the slope and the offset of the sensor. It is the recommended method of calibration for highest accuracy. In addition, this calibration method utilizes an automatic buffer recognition and compensation method.



**IMPORTANT:** the 2-point calibration mode **MUST** be performed when a new sensor is first put into operation so that accurate calibration data is available for possible later 1-point calibrations.

## 6.14 1-Point Calibration Explained

The 1-point calibration method is generally known as the "grab sample" calibration method. In the 1-point calibration method, the sensor may be removed from the application and placed into one buffer. It may also be left in the measurement process and calibrated by reference. 1-point calibration adjusts only the sensor offset. Since the sensor slope degrades much slower than the sensor offset, this method may be used as a frequent calibration method between more involved 2-point calibrations. For example, a user may choose to perform on-line 1-point calibrations weekly and 2-point calibrations monthly.

## 6.2 Performing a 2-Point Calibration

The 2-point calibration method utilizes an automatic buffer recognition and compensation system. For this system to operate properly, the user must first configure the proper buffers in the Set Buffers screen (see Section 5.24). If the buffers are not present in this menu, the user can override the automatic values and enter arbitrary values. However, the highest accuracy is provided when the user selects and uses buffers from this pre-defined table list. With the pre-defined buffers, the temperature variations in the buffer are automatically compensated for during the calibration process. If the buffer data is manually entered, the calibration buffer sample must be very temperature stable to achieve the same degree of accuracy.

### Procedure

1. Remove sensor from application. Rinse and clean if necessary.
2. Allow sensor to temperature equilibrate with the buffer as best as possible. With the sensor coming from an application solution that differs greatly in temperature from the buffer, the user may have to wait as much as 20 minutes for this to occur.
3. Scroll to the CAL menu section using the MENU key and press ENTER or the UP arrow key. **Cal pH** will then be displayed.
4. Press the ENTER key. The screen will display a flashing 1 for 1-point or a 2 for 2-point calibration. Using the UP arrow key, set for a 2-point calibration and press ENTER.



5. The display will prompt the user to place the sensor in the first buffer and press ENTER. If the sensor has been placed into this buffer already, once the temperature has stabilized, press ENTER to continue.
6. The present pH value will be displayed and the secondary line of the display will flash **Wait** for approximately 10-15 seconds. At this time the system is attempting to recognize the first buffer value from the two values entered into the Set Buffers selection.

7. The screen will display the buffer value to be used for calibration. If the user chooses to change this value, the arrow keys can be used to modify the value. Any value between 0.00 and 14.00 pH can be entered. After adjusting this value, or to accept the automatic value, press ENTER.
8. The system now begins acquiring data for the calibration value of this buffer point. As data is gathered, the units for pH and temperature may begin to flash. Flashing units indicates that this parameter is unstable. The data point acquisition will stop only when the data remains stable for a pre-determined time. This can be overridden by pressing ENTER. If the data remains unstable for 10 minutes, calibration will fail and **Cal Unstable** will be displayed.
9. Once the first calibration value has been established, the screen will prompt the user to move the sensor to the second buffer. At this point, rinse sensor with water and move the sensor into the second buffer solution. Allow temperature to stabilize, and then press ENTER.
10. The present pH value will be displayed and the secondary line of the display will flash **Wait** for approximately 10-15 seconds. At this time the system is attempting to recognize the second buffer value from the two values entered into the Set Buffers selection.
11. The screen will display the buffer value to be used for calibration. If the user chooses to change this value, the arrow keys can be used to modify the value. Any value between 0.00 and 14.00 pH can be entered. The second buffer must be at least 2 pH units away from the first. After adjusting this value, or to accept the automatic value, press ENTER.
12. The system now begins acquiring data for the calibration value of this buffer point. As data is gathered, the units for pH and/or temperature may again flash, indicating unstable parameters.
13. If accepted, the screen will display the message **PASS** with the new slope and offset readings, then it will return to the main measurement display. If the calibration fails, a message indicating the cause of the failure will be displayed and the FAIL icon will be turned on.

The sensor offset value in % from the last span calibration is displayed on the lower line of the Default Menu for information purposes.

### 6.3 Performing a 1-Point Calibration

The 1-point, or sample calibration method does not utilize the automatic buffer recognition and compensation system. This calibration method is intended to be primarily used as an on-line calibration method, in which the actual calibration point will not be a buffer value. However, the sensor can be removed and calibrated in a separate buffer. During calibration, the system will display the current pH reading and the user can manually enter a reference value from a lab grab-sample or a comparative reference instrument.

## Procedure

1. Determine whether the calibration will be done on-line or with the sensor removed and placed into a buffer. If the sensor is removed from the application, rinse and clean if necessary.
2. If the sensor has been removed and placed into a buffer, allow sensor to temperature equilibrate with the buffer as much as possible. With the sensor coming from an application which differs greatly in temperature difference, the user may have to wait as much as 20 minutes. If the sensor is on-line, the user may want to set the output HOLD feature prior to calibration to lock out any output fluctuations.
3. Scroll to the CAL menu section using the MENU key and press ENTER or the UP arrow key. **Cal pH** will then be displayed.
4. Press the ENTER key. The screen will display a flashing 1 for 1-point or a 2 for 2-point calibration. Using the UP arrow key, set for a 1-point calibration and press ENTER.



5. The system now begins acquiring data for the calibration value. As data is gathered, the units for pH and temperature may flash. Flashing units indicate that this parameter is unstable. The calibration data point acquisition will stop only when the data remains stable for a pre-determined amount of time. This can be overridden by pressing ENTER. If the data remains unstable for 10 minutes, the calibration will fail and the message **Cal Unstable** will be displayed.
6. The screen will display the last measured pH value [or the auto buffer value, if activated] and a message will be displayed prompting the user for the lab value. The user must then modify the screen value with the arrow keys and press ENTER. The system then performs the proper checks.
7. If accepted, the screen will display the message **PASS** with the new offset reading, and then it will return to the main measurement display. If the calibration fails, a message indicating the cause of the failure will be displayed and the FAIL icon will be turned on.

## 6.4 Temperature Calibration

The temperature input is factory calibrated for the highest accuracy. Temperature calibration is not recommended unless the installation involves long cable lengths. For example, at 50 feet, readings may be off  $\pm 0.2$  °C. The temperature calibration sequence is essentially a 1-point offset calibration that allows adjustments of approximately  $\pm 5$  °C.

The sensor temperature may be calibrated on line, or the sensor can be removed from the process and placed into a known solution temperature reference. In any case, it is critical that the sensor be allowed to reach temperature equilibrium with the solution in order to provide the highest accuracy. When moving the sensor between widely different temperature conditions, it may be necessary to allow the sensor to stabilize as much as one hour before the calibration sequence is initiated. If the sensor is on-line, the user may want to set the output HOLD feature prior to calibration to lock out any output fluctuations.

### Procedure

1. Scroll to the CAL menu section using the MENU key and press ENTER or the UP arrow key.
2. Press the UP arrow key until **Cal Temp** is displayed.
3. Press the ENTER key. The message **Place sensor in solution then press ENTER** will be displayed. Move the sensor into the calibration reference (if it hasn't been moved already) and wait for temperature equilibrium to be achieved. Press ENTER to begin the calibration sequence.
4. The message **Adjust temp value then press ENTER** will be displayed, and the right-most digit will begin to flash, indicating that the value can be modified. Using the UP and LEFT arrow keys, modify the value to the known ref solution temperature. Adjustments up to  $\pm 5$  °C from the factory calibrated temperature are allowed. Press ENTER.
5. The calibration data gathering process will begin. The message **Wait** will flash as data is accumulated and analyzed. The °C or °F symbol may flash periodically if the reading is too unstable.
6. Once completed, the display will indicate **PASS** or **FAIL**. If the unit fails, the temperature adjustment may be out of range, the sensor may not have achieved complete temperature equilibrium, or there may be a problem with the temperature element. In the event of calibration failure, it is recommended to attempt the calibration again immediately.



## Part 7 – Maintenance and Troubleshooting

---

### 7.1 System Checks

1. If the FAIL icon is flashing on the display, check the Fault List to determine the cause of the failure. To access the Fault List, press the MENU/ESC key until the DIAG menu appears. Then press the UP arrow key until the Fault List appears. Press the ENTER key to access the Fault List, and the highest priority fault message will be displayed. For a list of all messages and possible causes/solutions, see message table at the end of this section.
2. In **ALL** environments, connect an earth ground jumper to earth terminal connection on transmitter.
3. Perform a two-point calibration with two fresh buffers prior to sensor installation.
4. Check sensor cable color to terminal strip markings.
5. For highly unstable behavior, remove sensor from the process and measure the process solution in a plastic beaker. If the reading now stabilizes, place wire in beaker solution and actual process solution to determine if a ground loop exists.
6. Verify that the black rubber shipping boot has been removed from the end of the sensor prior to submersion. If the sensor has been left to dry out, allow sensor to be submerged in buffer or water to re-hydrate for at least 4 hours. The saltbridge may need replacement if the sensor has dried out for too long.

### 7.2 Instrument Checks

1. Remove sensor completely and connect 1100 Ohms from the yellow to black sensor input leads. Make sure the unit is configured for a Pt1000 thermal element and that the temperature is not in manual locked mode. Also, connect a wire jumper from the red cable lead input to the green cable lead input. The temperature reading should be approximately 25°C, the pH reading should be approximately 7.00 pH, and the sensor mV reading should be between -20 and +20 mV.
2. With a DMM, measure the DC voltage from the white sensor lead connection to the black sensor lead connection. With the positive DMM lead on the white wire, the meter should read between -4.5 and -5.5 VDC.

3. For the DC transmitter variation, verify that power supply has required voltage based on size of resistance in current loop. Large resistive loads can reduce available power for transmitter.

### **7.3 Display Messages**

The Q45 Series instruments provide a number of diagnostic messages that indicate problems during normal operation and calibration. These messages appear as prompts on the secondary line of the display or as items on the Fault List as follows.

The following messages will appear as prompts:

MESSAGE	DESCRIPTION	POSSIBLE CORRECTION
<b>Max is 200</b>	Entry failed, maximum value allowed is 200.	Reduce value to $\leq 200$
<b>Min is 200</b>	Entry failed, minimum value allowed is 200.	Increase value to $\geq 200$
<b>Cal Unstable</b>	Calibration problem, data too unstable to calibrate.	Clean sensor, get fresh cal solutions, allow temperature and pH readings to fully stabilize, do not handle sensor or cable during calibration.
<b>Slope HIGH</b>	Sensor slope from calibration is greater than 110%.	Get fresh cal solutions, allow temperature and pH readings to fully stabilize, check for correct buffer values
<b>Slope LOW</b>	Sensor slope from calibration is less than 80%.	Clean sensor, get fresh cal solutions, allow temperature and pH readings to fully stabilize, check for correct buffer values.
<b>Offset HIGH</b>	Sensor offset from calibration is less than $-90$ mV or greater than $+90$ mV	Clean or replace saltbridge, replace reference cell solution, clean sensor, get fresh cal solutions, allow temperature and pH readings to fully stabilize, check for correct buffer values.
<b>Out of Range</b>	Input value is outside selected range of the specific list item being configured.	Check manual for limits of the function to be configured.
<b>Locked!</b>	Transmitter security setting is locked.	Enter security code to allow modifications to settings.
<b>Unlocked!</b>	Transmitter security has just been unlocked.	Displayed just after security code has been entered.
<b>TC-F25 lock!</b>	The TC selection is in F25 mode, locked at $25^{\circ}\text{C}$	Calibration and TC adjustment cannot be performed while the TC is in F25 mode. To allow access to TC calibrations, change TC mode from F25 (fixed 25) to SENS (sensor).

The following messages will appear as items on the Fault List:

MESSAGE	DESCRIPTION	POSSIBLE CORRECTION
<b>Sensor High</b>	The raw signal from the sensor is too high.	Check wiring connections to sensor.
<b>Sensor Low</b>	The raw signal from the sensor is too low.	Check wiring connections to sensor.
<b>pH too High</b>	The pH reading is > 14.00 pH.	The pH reading is over operating limits.
<b>pH too Low</b>	The pH reading is < 0.00 pH.	The pH reading is under operating limits.
<b>Temp High</b>	The temperature reading is > 110 °C.	The temperature reading is over operating limits. Check wiring and expected temp level. Perform RTD test as described in sensor manual. Recalibrate sensor temperature element if necessary.
<b>Temp Low</b>	The temperature reading is < -10 °C	The temperature reading is under operating limits. Check wiring and expected temp level. Perform RTD test as described in sensor manual. Recalibrate sensor temperature element if necessary.
<b>TC Error</b>	TC may be open or shorted.	Check sensor wiring and perform RTD test as described in sensor manual.
<b>Meas Break</b>	Leakage detected on measuring electrode of sensor.	Measuring electrode glass may be cracked or broken. Electrical noise may falsely trip this diagnostic. Turn off glass diagnostic feature and see if sensor operates correctly. If it does not, sensor must be replaced.
<b>Ref Break</b>	Leakage detected on reference electrode of sensor.	Reference glass electrode may be cracked or broken. Electrical noise may falsely trip this diagnostic. Turn off glass diagnostic feature and see if sensor operates correctly. If it does not, sensor must be replaced.

MESSAGE	DESCRIPTION	POSSIBLE CORRECTION
<b>pH Cal Fail</b>	Failure of pH calibration.	Clean sensor, get fresh cal solutions, regenerate sensor (if necessary) and redo calibration. If still failure, sensor slope may be less than 80% or offset may be out of range. Perform sensor tests as described in sensor manual. Replace sensor if still failure.
<b>TC Cal Fail</b>	Failure of temperature calibration.	Clean sensor, check cal solution temperature and repeat sensor temp calibration. TC calibration function only allows adjustments of +/- 6 °C. If still failure, perform sensor tests as described in sensor manual. Replace sensor if still failure. Note that TC offset may also be adjusted using the Cal TC Factor function (See Section 6.5) which involves no calibration reference solutions.
<b>Eeprom Fail</b>	Internal nonvolatile memory failure	System failure, consult factory.
<b>Chcksum Fail</b>	Internal software storage error.	System failure, consult factory.
<b>Display Fail</b>	Internal display driver fail.	System failure, consult factory.
<b>mV Cal Fail</b>	Failure of factory temperature calibration.	Consult factory.

## 7.4 Cleaning the Sensor

Keep the sensor as clean as possible for optimum measurement accuracy - this includes both the saltbridge and the measuring electrode glass. Frequency of cleaning depends upon the process solution.

Carefully wipe the measuring end of the sensor with a clean soft cloth. Then rinse with clean, warm water - use distilled or de-ionized water if possible. This should remove most contaminate buildup.

Prepare a mild solution of soap and warm water. Use a non-abrasive detergent (such as dishwashing liquid).



**NOTE: DO NOT use a soap containing any oils (such as lanolin). Oils can coat the glass electrode and harm sensor performance.**

Soak the sensor for several minutes in the soap solution.

Use a small, extra-soft bristle brush (such as a mushroom brush) to thoroughly clean the electrode and saltbridge surfaces. If surface deposits are not completely removed after performing this step, use a dilute acid to dissolve the deposits. After soaking, rinse the sensor thoroughly with clean, warm water. Placing the sensor in pH 7 buffer for about 10 minutes will help to neutralize any remaining acid.



**NOTE: DO NOT soak the sensor in dilute acid solution for more than 5 minutes. This will help to prevent the acid from being absorbed into the saltbridge.**



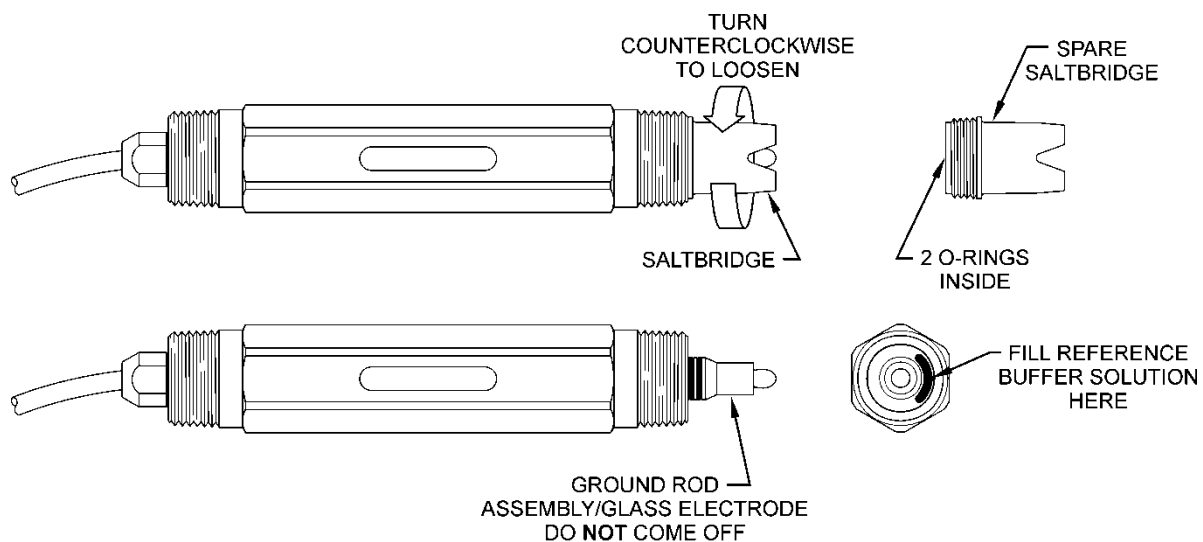
**WARNING: ACIDS ARE HAZARDOUS. Always wear eye and skin protection when handling. Follow all Material Safety Data Sheet recommendations. A hazardous chemical reaction can be created when certain acids come in contact with process chemicals. Make this determination before cleaning with any acid, regardless of concentration.**

### 7.5 Replacing the Saltbridge and Reference Buffer Solution

1. Hold the sensor with the process electrode pointing up. Place a cloth or towel around the saltbridge. Turn the saltbridge counterclockwise (by hand) to loosen and remove the saltbridge. Do NOT use pliers.
2. Pour out the old reference buffer by inverting the sensor (process electrode pointing down). If the reference buffer does not run out, gently shake or tap the sensor.
3. Rinse the reference chamber of the sensor with de-ionized water. Fill the reference chamber of the sensor with fresh Reference Cell Buffer. The chamber holds 6 to 7 mL of solution. MAKE SURE that 6 to 7 mL is used when refilling. The chamber should be FULL.
4. Inspect the new saltbridge to verify that there are 2 o-rings inside the threaded section of the saltbridge
5. Place the new saltbridge over the ground assembly of the sensor. Place a cloth or towel around the saltbridge and hand-tighten the saltbridge by turning it clockwise.



**NOTE:** Every ATI Q25P Sensor includes a spare bottle of Reference Buffer Solution, 7.0 pH. This is NOT typical pH 7 buffer, it is a special “high-capacity” buffer developed to ensure the highest possible stability of the reference portion of the pH measurement. No substitutions should be made.



**Figure 30 - Replacing the Saltbridge and Reference Buffer**

## 7.6 Troubleshooting

The first step in resolving any measurement problem is to determine whether the trouble lies in the sensor or the transmitter. Since measurement problems can often be traced to dirty sensor electrode glass and/or saltbridge, cleaning the sensor using the method outlined in Section 7.4 should always be the first step in any troubleshooting.

If the sensor cannot be calibrated after cleaning, replace the saltbridge and reference cell buffer 7 pH as outlined in Section 7.5.

If the sensor still cannot be calibrated, perform the following test. A multimeter, 7 pH buffer and another buffer at least 2 pH units away will be needed.

1. With transmitter power on and sensor connected, place the multimeter's positive (+) lead on the white position of the transmitter terminal strip and the negative (-) lead on the black position. The multimeter should read between -4.2 and -6.5 VDC.
2. Disconnect the sensor's red, green, yellow, and white wires from the transmitter or junction box. Re-check Step 1.
3. Place the sensor in pH 7 buffer. As in calibration, allow the temperatures of the sensor and buffer to equilibrate at room temperature (approximately 25 °C).
4. Verify that the sensor's temperature element (Pt1000 RTD) is functioning properly by measuring the resistance between the sensor's yellow and black wires. The nominal resistance value at 25 °C is 1097 ohms. Use the following table as a guide to the approximate resistance value:

°C	RTD Ω
20	1078
25	1097
30	1117
35	1136

5. Reconnect the yellow and white wires.



6. Connect the multimeter's positive (+) lead to the red wire and its negative (-) lead to the green wire. With the sensor in the pH 7 buffer at approximately 20-30 °C, measure the DC millivolts. The sensor offset reading should be between -50 and +50 mV. If it is not, replace sensor reference solution and saltbridge (See Section 7.5) and re-test.
7. With the multimeter connected as in Step 5, rinse the sensor with clean water and place it in the second buffer. Allow the temperatures to equilibrate as before. Now measure the sensor span reading. Use the following table to determine approximate mV:

pH	mV
2.00	+296
4.00	+178
7.00	0
9.18	-129
10.00	-178



**NOTE:** The mV values listed above are for ideal conditions (sensor offset = 0 mV) and therefore represent midpoints in a range. The table shows the difference in mV which should be seen when going from one pH value to another. For example, at 7.00 pH, the mV reading will be from -50 to +50 mV (at room temperature) if the sensor is working properly. If the reading is exactly +20 mV, then going to 4.00 pH buffer should produce a reading of +198 mV, or a difference of +178 mV.

# Spare Parts

---

## **Part No.**

## **Description**

### **Spare Electronics**

07-0047	Q45P pH transmitter, External Power (5-17 VDC)
03-0340	Q45P Front Lid Assembly
03-0361	External Power PCB Assembly

### **Spare Sensors**

07-0062	Q25P1 pH Sensor 30'
63-0009	Submersible pH Sensor, 25', Pt100
63-0013	Twist-Lock probe, pH with Temperature Comp., 25', Pt100
63-0053	Lock-n-Load pH Sensor, 25'
63-0051	Lock-n-Load Temperature Compensator, 25'

### **Spare Flowcells**

00-1527	Twist-Lock pH Seal Acrylic Flowcell Assembly
---------	--

### **Spare Sensor Components**

63-0017	$\frac{3}{4}$ " NPT Flow "T" adapter for (63-0013)
63-0021	1" NPT Flow "T" adapter for (63-0013)
05-0060	Saltbridge replacement
09-0034	pH 4 Buffer, 1000 mL
09-0036	pH 7 Buffer, 1000 mL
09-0037	pH 10 Buffer, 1000 mL
05-0057	pH/ORP Sensor Regeneration Kit for P1, R1 and R2 sensors
05-0067	pH/ORP Sensor Regeneration Kit for P2 sensor

### **Misc Components**

07-0100	Junction box
31-0057	Sensor interconnect cable

**Lock/Unlock Code: 1451**