

INSTALLATION & MAINTENANCE INSTRUCTIONS

DESCRIPTION / IDENTIFICATION

The BVISF1 series control valve is an electronic pressure regulator designed to precisely and proportionally control the pressure of gaseous based on an electronic signal.

The BVISF1 operates using two normally closed solenoid valves, a pressure sensor, and a control circuit. One valve is actuated to allow unregulated supply media into the system. The second valve is actuated to allow working media to vent to atmosphere. The pressure sensor provides feedback to the control circuit. The control circuit compares the pressure sensor feedback to the user supplied electronic command signal and actuates the appropriate valve until the two signals match.

The BVISF1 series can be teamed with a variety of one-to-one pressure volume boosters for even greater flow.

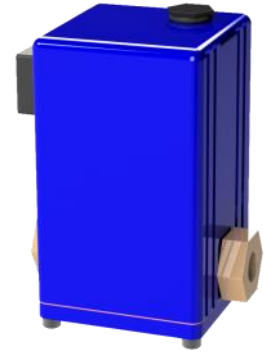

BURLING VALVE, LLC.
8250 N. 600 West
McCordsville, IN 46055
317.335.2602

SPECIFICATIONS

ELECTRICAL

Unless specified by label on unit, consult factory with model and serial number for supply voltage specifications.

SUPPLY CURRENT	< 80 mA
COMMAND SIGNAL	4-20 mA Differential
COMMAND SIGNAL IMPEDANCE	Current=100 Ω

MECHANICAL

PRESSURE RANGES	Full Vacuum - 150 psig (29.9 in. HG (Vac) - 10.3 Bar)
OUTPUT PRESSURE†	0-100% of range
FLOW RATE	0.80 SCFM @ 80 PSIG (23 L/min @ 5.52 Bar)
Min CLOSED END VOLUME	2 in ³
PORT SIZE	1/8" NPT
FILTRATION RECOMMENDED	40 Micron (included)
LINEARITY/HYSTERESIS	<±0.4% F.S. BFSL
REPEATABILITY	<±0.2% F.S.
ACCURACY	<±0.5% F.S.

PHYSICAL

OPERATING TEMPERATURE	32-104°F (0-40°C) (T4)
WEIGHT	2 lbs. (0.91 Kg)
PROTECTION RATING	IP65
HOUSING	Blue Anodized Aluminum

† Pressure ranges are customer specified. Output pressures other

HAZARDOUS AREA CLASSIFICATION

ISF1: Nonincindive for use in Class I, II & III, Division 2, Groups C thru G T4; Type 4X hazardous (classified) locations and suitable for use in Class II, Division 2, Groups E, F and G T4 ; Type 4X hazardous (classified) locations.

May be used with any non-corrosive compressible media compatible with the wetted materials.

Special Condition for Use:

1. *With Intrinsically Safe Process Connections.* Intrinsically safe process connections refers to process connections that under any condition of installation or operation will not change the nature of the hazardous (classified) area from a division 2 to a division 1 location.

NOTES: End user must determine fitness and suitability of the ISF1 control valve for their application.

WETTED MATERIALS

PARAMTERS	Port 1 (Pressure Port)	Port 2 (Reference Port)
COVERS	High Temperature Polyamide	High Temperature Polyamide
SUBSTRATE	Alumina Ceramic	Alumina Ceramic
ADHESIVES	Epoxy, RTV	Epoxy, RTV
ELECTRONIC COMPONENTS	Ceramic, Silicon	Silicon, Glass, Gold, Solder

Before you get started, please read these warnings:

- ◆ Examine the product. Ensure that you received what you ordered.
- ◆ Read this guide first before you start and save it for later use.
- ◆ All compressed air and power should be shut off before installing, removing or performing maintenance on this product.
- ◆ Installation and use of this product should be under the supervision and control of properly qualified personnel in order to avoid the risk of injury or death.
- ◆ Media vents through exhaust port. If the media is hazardous (classified), the exhaust port should be vented to a different location to maintain a Class I, Division 2 area at the unit.

Pneumatic Connections:

1. A typical 20 micron (minimum 40 micron) in-line filter is recommended on the inlet of the BVISF1.
2. Connect supply pressure to the “IN” INLET PORT (figure 1). See Table 1 for maximum supply pressure.
3. Connect the “OUT” OUTLET PORT (figure 1) to the device being controlled.
4. Media vents through exhaust port. If the media is hazardous (classified), the threaded exhaust port (figure 1) should be vented to a different location to maintain a Class I, Division 2 area at the BVISF unit.
5. Proceed with electrical connection.

**TABLE 1
RATED PRESSURE FOR BVISF1 VALVES**

For valves ordered with MAX. calibrated pressure of	Max. inlet pressure is
Vacuum up to 10 psig (0.69 bar)	Consult factory
10.1 up to 30 psig (0.70 up to 2 bar)	35 psig (2.4 bar)
31 up to 100 psig (2.1 up to 7 bar)	110 psig (7.6 bar)
101 up to 150 psig (7 up to 12 bar)	150 psig (12 bar)

**TABLE 2
BVISF1 PIN DESIGNATORS**

PIN	FUNCTION
1	DC COMMON
2	COMMAND (-)
3	NC
4	COMMAND (+)
5	NC
6	POWER

Electrical Connections:

1. Ensure all power is off before making any electrical connections.
2. Figure 1 shows the location of the BVISF1 electrical connector and figure 2 shows the connector. Table 2 identifies each connection
3. Unless specified by label on unit, consult factory with model and serial number for supply voltage specifications.
4. Connect ground wire to intrinsically safe ground (figure 1).

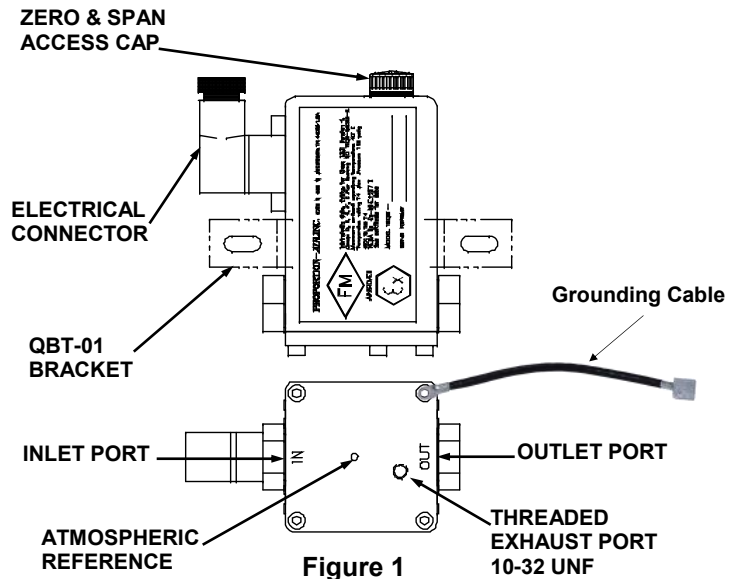

Figure 1

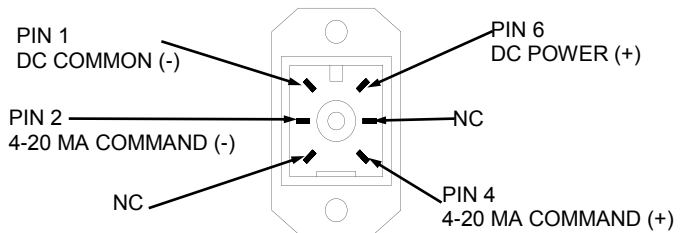

Figure 2

Example Part Number : **BVISF1 T B N I X Z P 150 PS G BR**

YOUR PART NUMBER : **BVISF1 T** **I X** **P 150 PS G BR**

Section ---> 1 2 3 4 5 6 7 8 9 10 11 12 Options

1 Series

BVISF1	Nonincindive BVISF1*
BVISQB1	Intrinsically Safe BVISQB1 <small>*BVISF Potted for Hazardous Media Control</small>

2 Sensor Type

T	-14.7 to 150 psig
----------	-------------------

3 Manifold Material

B	Brass (<i>standard</i>)
A	Aluminum

4 Thread Type

N	NPT (<i>standard</i>)
P	BSPP

5 Input Signal Range

I	4 to 20 mA DC
----------	---------------

6 Monitor Signal Range

X	No Monitor
----------	------------

7 Zero Offset

N	0% Pressure is Below Atmosphere
P	0% Pressure is Above Atmosphere
Z	0% Pressure is Zero (<i>Typical</i>)

8 Zero Offset Pressure

Typical is 0 (blank) - If Greater than 30% of Full Scale Pressure (#9 below) Please Consult Factory.*

*If Z for Zero Offset (#7), please leave blank

9 Full Scale Pressure Type

N	100% Pressure is Below Atmosphere
P	100% Pressure is Above Atmosphere
Z	100% Pressure is at Zero

10 Full Scale Pressure

Must be less than or equal to 150 psig

11 Pressure Unit

PS	PSI	Inches Hg	IH
MB	Millibars	Inches H ₂ O	IW
BR	Bar	mm H ₂ O	MW
KP	Kilopascal	Kilograms/cm ²	KG
MP	Megapascal	Torr*	TR
MH	mm Hg	<small>*Requires A for Pressure Unit of Measure</small>	

12 Pressure Unit of Measure

A	Absolute Pressure
G	Gage Pressure

Options

R1	Rotate Connector 180 Degrees
BR	Install Foot Bracket
P1	12 VDC Power

MOUNTING BRACKET

Type	Bracket P#
Wrap-Around	QBT-01

Please Note: The user has the additional responsibility of supplying and or ensuring that the connector/cable that is used with any Burling Valve BVISQB or BVISF1 series FM approved product, meets all local and national codes for intrinsically safe wiring.

RE-CALIBRATION PROCEDURE

All BVISF1 valves come calibrated from the factory by trained personnel using precision calibration equipment. The BVISF1 is a closed loop control valve using a precision electronic pressure sensor. Typical drift is less than 1% over the life of the product. If your BVISF1 appears to be out of calibration by more than 1%, it is not likely to be BVISF1. Check the system for plumbing leakage, wiring and electronic signal levels. Verify the accuracy of your measuring equipment before re-calibrating. If the BVISF1 valve needs re-calibration, use the procedure described below:

Re-calibration:

1. Wire the BVISF1 according to the section titled "Electrical Connections."
2. Connect a precision pressure gage or pressure transducer to the OUTLET PORT of the BVISF1.

NOTE: There must be a closed volume of at least 1 in³ between the OUTLET PORT and the measuring device for the BVISF1 to be stable.

3. Provide supply pressure to the INLET PORT of the BVISQB1. (See figure 1). Make sure supply pressure does not exceed the rating for the valve.

4. Remove the zero and span plug on top of the BVISF1 to access the ZERO and SPAN adjustment potentiometers (figure 1).

NOTE: Only use this step if your device is totally out of calibration. If it is slightly out of calibration, omit this step and move on to paragraph 5. Using a small screwdriver, turn both potentiometers 15 turns clockwise. Then turn them 7 turns counter clockwise. This will put the BVISF1 roughly at mid scale.

5. Set the electrical command input to 20mADC. Adjust the SPAN potentiometer until MAXIMUM desired pressure is reached (clockwise to increase pressure).
6. Set the electrical command input to 10 percent of full value (5.6mA).
7. Adjust the ZERO potentiometer until 10 percent of maximum desired pressure is reached. (clockwise increases pressure).
8. The ZERO and SPAN potentiometers interact slightly. Repeat steps 5-10 until no error exists.
9. Verify unit shuts off by going to 4mADC command. Check linearity by going to at least six pressures throughout the full range.

BVISF1 & BRACKET DIMENSIONS

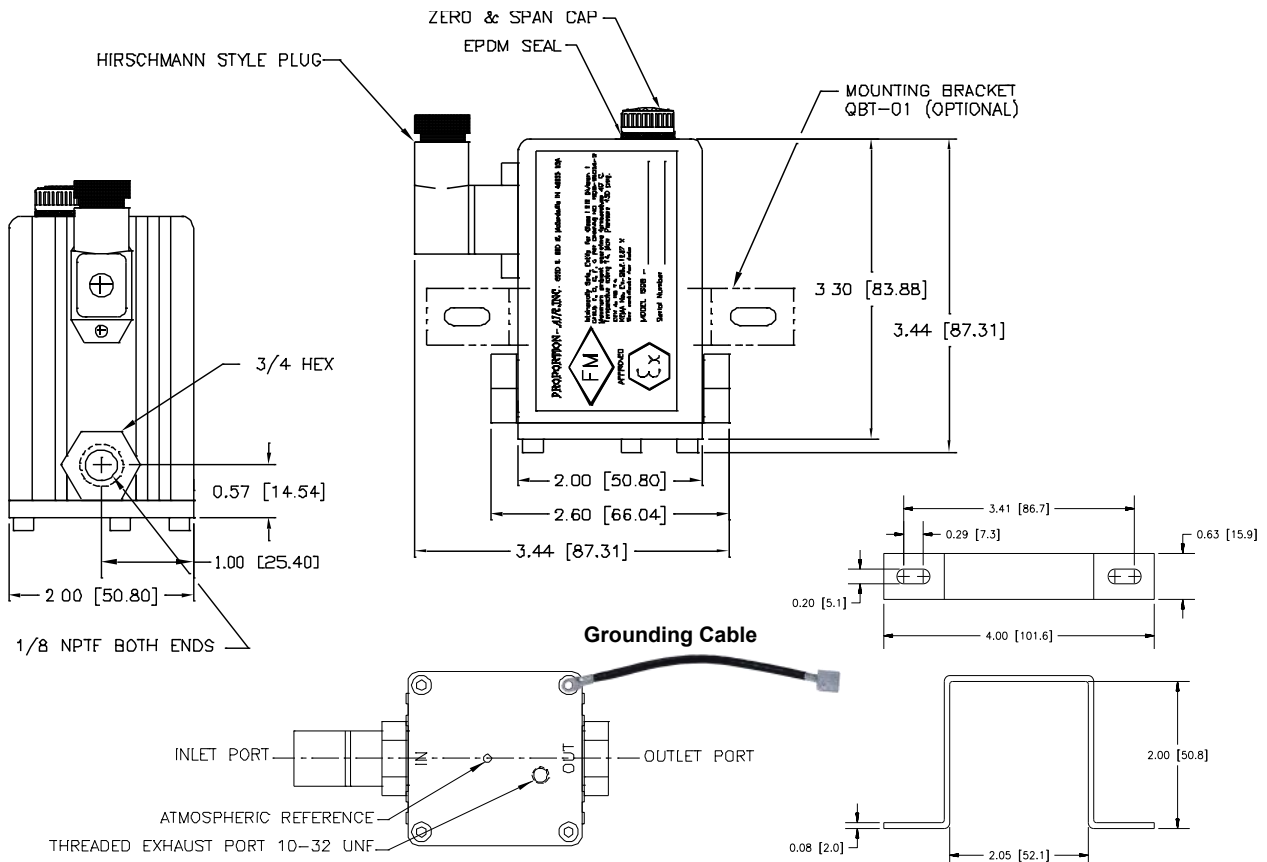



Please read all of the following Safety Precautions before installing or operating any Burling Valve, Inc. equipment or accessories. To confirm safety, be sure to observe 'ISO 4414: Pneumatic Fluid Power - General rules relating to systems' and other safety practices.



Warning

Improper operation could result in serious injury to persons or loss of life!

1. PRODUCT COMPATIBILITY

Burling Valve, Inc. products and accessories are for use in industrial pneumatic applications with compressed air media. The compatibility of the equipment is the responsibility of the end user. Product performance and safety are the responsibility of the person who determined the compatibility of the system. Also, this person is responsible for continuously reviewing the suitability of the products specified for the system, referencing the latest catalog, installation manual, Safety Precautions and all materials related to the product.

2. EMERGENCY SHUTOFF

Proportion, Inc. products cannot be used as an emergency shutoff. A redundant safety system should be installed in the system to prevent serious injury or loss of life.

3. EXPLOSIVE ATMOSPHERES

Products and equipment should not be used where harmful, corrosive or explosive materials or gases are present. Unless certified, Burling Valve, Inc. products cannot be used with flammable gases or in hazardous environments.

4. AIR QUALITY

Clean, dry air is not required for Burling Valve, Inc. products. However, a 40 micron particulate filter is recommended to prevent solid contamination from entering the product.

5. TEMPERATURE

Products should be used with a media and ambient environment inside of the specified temperature range of 32°F to 158°F. Consult factory for expanded temperature ranges.

6. OPERATION

Only trained and certified personnel should operate electronic and pneumatic machinery and equipment. Electronics and pneumatics are very dangerous when handled incorrectly. All industry standard safety guidelines should be observed.

7. SERVICE AND MAINTENANCE

Service and maintenance of machinery and equipment should only be handled by trained and experienced operators. Inspection should only be performed after safety has been confirmed. Ensure all supply pressure has been exhausted and residual energy (compressed gas, springs, gravity, etc.) has been released in the entire system prior to removing equipment for service or maintenance.



Caution

Improper operation could result in serious injury to persons or damages to equipment!

1. PNEUMATIC CONNECTION

All pipes, pneumatic hose and tubing should be free of all contamination, debris and chips prior to installation. Flush pipes with compressed air to remove any loose particles.

2. THREAD SEALANT

To prevent product contamination, thread tape is not recommended. Instead, a non-migrating thread sealant is recommended for installation. Apply sealant a couple threads from the end of the pipe thread to prevent contamination.

3. ELECTRICAL CONNECTION

To prevent electronic damage, all electrical specifications should be reviewed and all electrical connections should be verified prior to operation.

Exemption from Liability

1. **Burling Valve, Inc.** is exempted from any damages resulting from any operations not contained within the catalogs and/or instruction manuals and operations outside the range of its product specifications.

2. **Burling Valve, Inc.** is exempted from any damage or loss whatsoever caused by malfunctions of its products when combined with other devices or software.

3. **Burling Valve, Inc.** and its employees shall be exempted from any damage or loss resulting from earthquakes, fire, third person actions, accidents, intentional or unintentional operator error, product misapplication or irregular operating conditions.

4. **Burling Valve, Inc.** and its employees shall be exempted from any damage or loss, either direct or indirect, including consequential damage or loss, claims, proceedings, demands, costs, expenses, judgments, awards, loss of profits or loss of chance and any other liability whatsoever including legal expenses and costs, which may be suffered or incurred, whether in tort (including negligence), contract, breach of statutory duty, equity or otherwise.

Warranty

Burling Valve, Inc. products are warranted to the original purchaser only against defects in material or workmanship for one (1) year from the date of manufacture. The extent of Burling Valve's liability under this warranty is limited to repair or replacement of the defective unit at Burling Valve's option. Burling Valve shall have no liability under this warranty where improper installation or filtration occurred.