

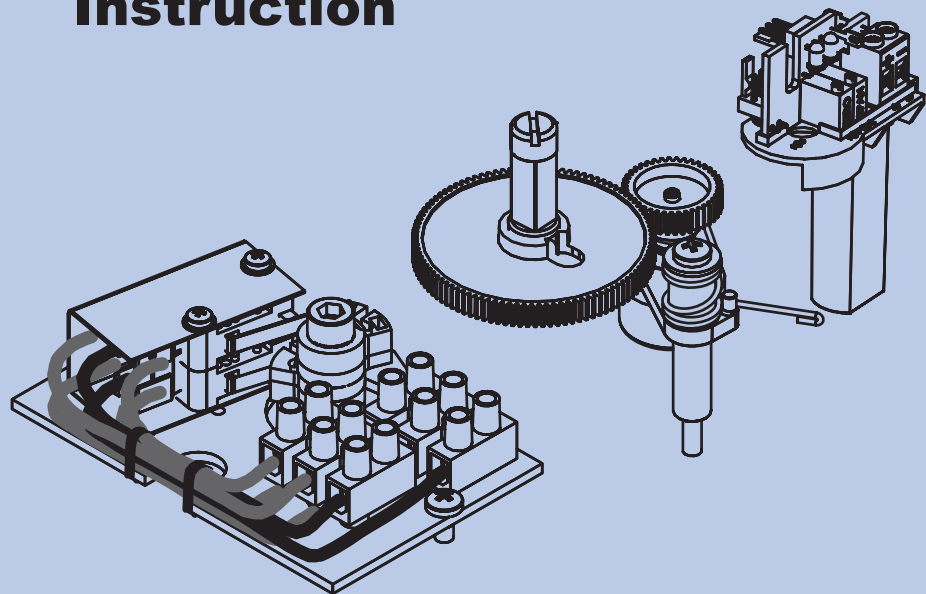

VAC, Valve Accessories & Controls.
www.vac.se

V200 FEEDBACK OPTION

Installation, Operation and Maintenance Instruction





V200 POSITIONER

www.vac.se

CONTENTS

1 INTRODUCTION	4
1.1 Principle of Operation.....	4
1.2 Product Identification.....	4
1.3 Safety Instructions.....	4
2 FEEDBACK INSTALLATION	5
2.1 Connections	5
2.2 Front cover and indicator	5
2.2.1 Removing the front cover	5
2.2.2 Removing the indicator	5
2.3 4-20mA Transmitter installation.....	6
2.3.1 Gearwheel installation.....	6
2.3.2 Potentiometer installation.....	6
2.3.3 4-20mA Transmitter setup	7
2.3.4 Connecting the control signal.....	7
2.3.5 4-20mA Transmitter Calibration.....	8
2.3.6 Trouble shooting - Reset and Calibration.....	8
2.4 Switch option installation.....	9
2.4.1 Switch and cam installation.....	9
2.4.2 Electrical installation.....	9
2.4.3 Switch calibration	9
3 SPARE PARTS	10
3.1 Exploded drawing feedback options	10
3.2 Spare parts list feedback options	11
4 SPECIFICATIONS	12
4.1 Specifications feedback options.....	12

1 INTRODUCTION

1.1 Principle of operation

The V200 feedback options allows for accurate position feedback, where on-off (open/closed) indication (switches) or continuous 4-20mA transmission (or simple potentiometer) is required. Any feedback module can be factory or field installed inside the V200 positioner housing with no special parts or mounting brackets. This creates a very compact and simple package that is completely sealed.

The various feedback options are connected to the positioner main drive shaft(1) which is connected to the actuator shaft via the positioner spindle, assisting in a more direct and accurate actuator/valve monitoring. A position change moves the V200 spindle and switch cam(2) for on-off (or open/closed) indication. The 4-20mA position transmitter mkII(3) responds to changes proportionally in the actuator/valve package.

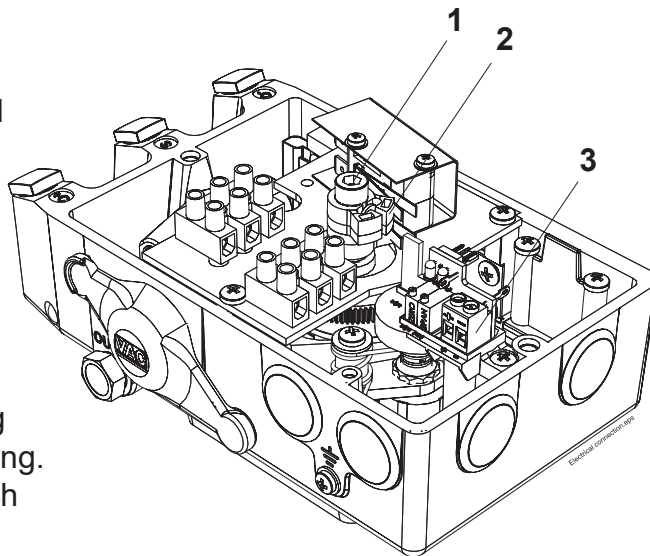

It is recommended that the V200 positioner be calibrated before installing feedback options.

1.2 Product identification

The V200 identification tags, Serial number tag(1), product - model tag(2) and feedback option tag(3), are placed as shown. The product model tag contains information on control signal, maximum working pressure and temperature ranges. Other information can be shown depending on the model.

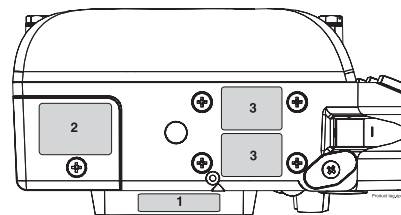

1.3 Safety instruction



Not for use in Hazardous locations.

Feedback options described in this manual are for for General purpose only.



CAUTION:

Beware of moving parts when positioner is operated!



CAUTION: Beware of parts with live voltage!

A voltage, which is normally not dangerous, is supplied to the positioner. Avoid touching live parts and bare wires as well as short circuiting live parts and the housing.

2. FEEDBACK INSTALLATION

2.1 Connections

 – Grounding point

1. – Terminal block, switches
2 X 3 Connections
Maximum cable size AWG 11 (4 mm²)
2. – Terminal block, Position Transmitter
Maximum cable size AWG 13 (2.5 mm²)

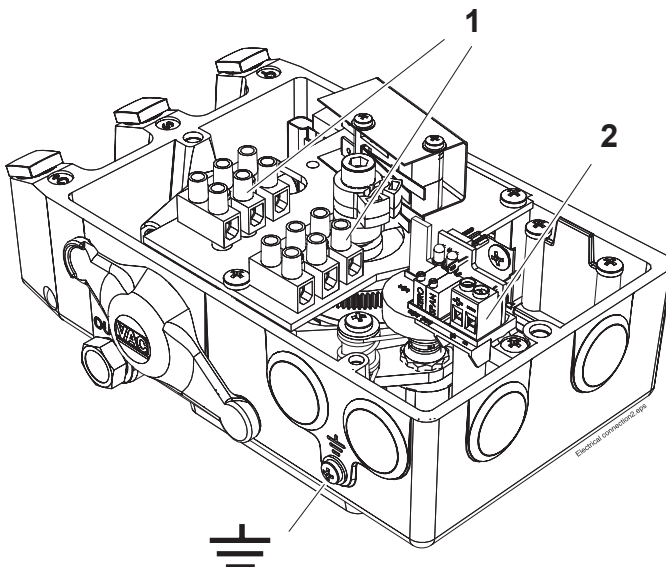

2.2 Front cover and indicator

2.2.1 Removing the front cover

Loosen the two screws(1) and remove the front cover.

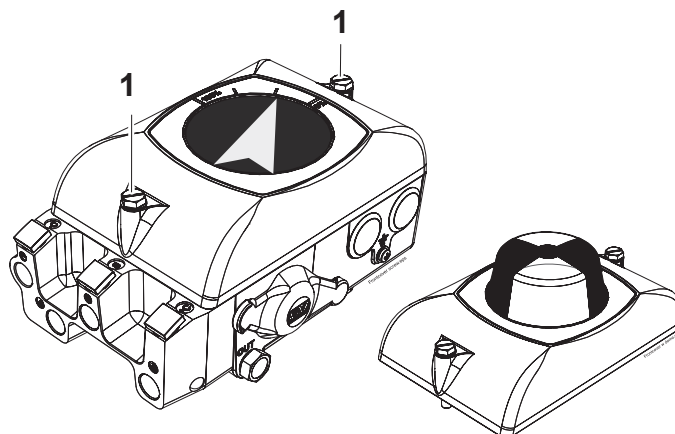

2.2.2 Removing the indicator

Pull the indicator(2) straight up, it is a friction fit.

Important Note!

Note the indicator's position so it can be installed in the same position.

Installing the indicator

Install the indicator in place over the drive shaft and press it straight down. Be sure to press the indicator completely down so that it does not interfere with the indicator cover (clear cover). Turn the indicator to the proper display position.

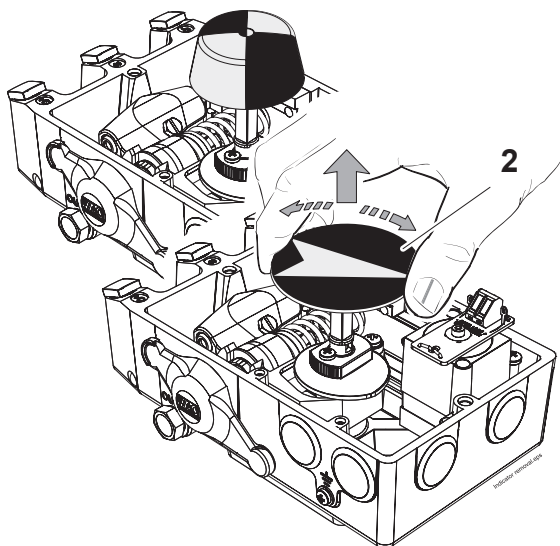

2.3 4-20mA transmitter installation

2.3.1 Gearwheel installation

1. Remove the front cover and indicator on the V200 positioner. (see page 4)
2. Remove Indicator screw(1).
3. Install the gearwheel(2) so that it aligns over the cam locking nut screw(3).
4. Secure the gearwheel with the Indicator screw(1).

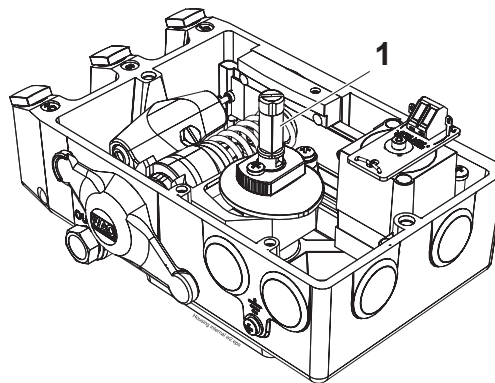

2.3.2 Potentiometer installation

1. Install the potentiometer module(4) in the designed section of the unit as shown. Tighten the screw that secures the pot arm and spring. The pot gearwheel should be aligned and secured to the larger gearwheel.
2. Install the potentiometer board(5) or the 4-20mA transmitter module(6) into the designed position and tighten the respective screws.
3. When used for the 4-20mA feedback, secure the potentiometer connector(7) to the transmitter (6). For potentiometer use only, the connector(7) will attach to the terminal block(5) and be used with an external position transmitter.

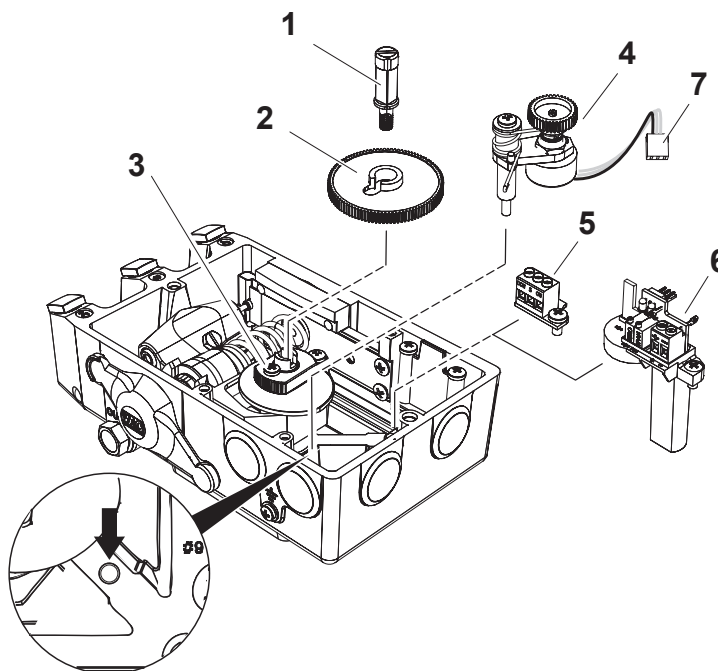

2.3.3 4-20mA transmitter setup



The Position Transmitter is shipped for direct (CCW) turning, range 0-90°

1. Determine the direction for increasing mA output. Direct (CCW) or Reverse (CW).
2. The direction of rotation is simply determined by watching the positioner drive shaft(1).
3. CCW rotation: the potentiometer lead connector(2) fitted with the Black or Blue colored lead facing to the left.
4. CW rotation: the potentiometer lead connector(2) fitted with the Black or Blue colored lead facing to the right.

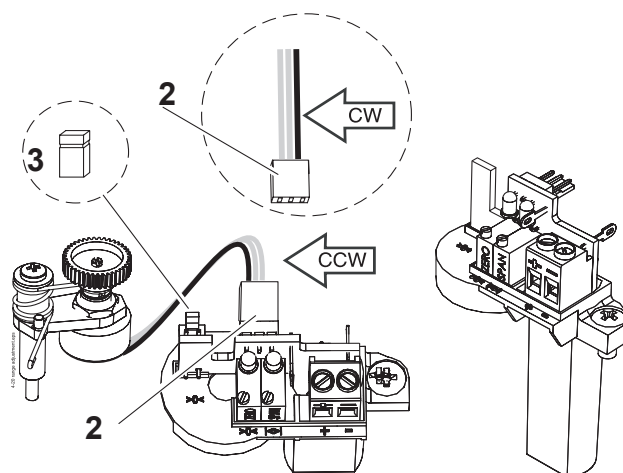
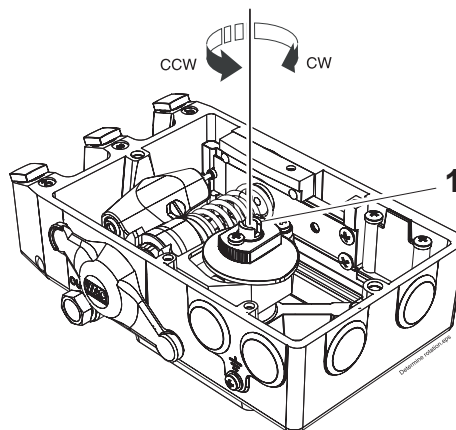

The position transmitter can be calibrated in a range from 25° up to 115°.
 25° - 70° with Jumper(3).
 70° - 115° no Jumper(3).

2.3.4 Connecting the control signal

1. Connect the signal cable to the proper pole on the terminal block(1).
 Maximum cable size AWG 13 (2.5 mm²)

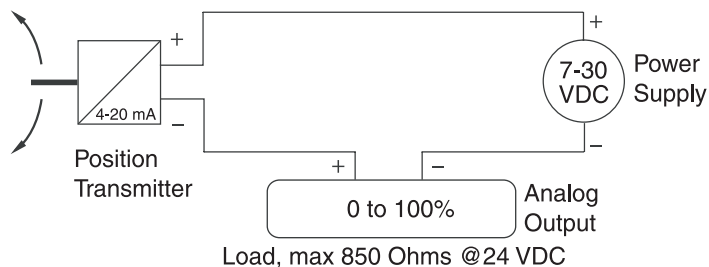
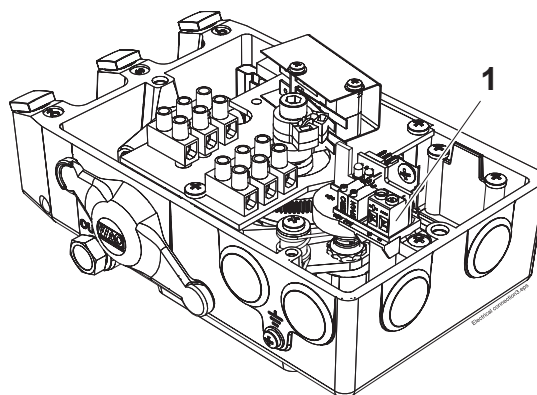



V200 POSITIONER

www.vacaccessories.com

2.3.5 4-20mA transmitter Calibration



Make sure V200E/P has first been properly calibrated!

1. Power up the current loop.
2. Connect a low ohmic ampere meter over the test points(5).
3. Set the valve/actuator to the closed/zero position (4mA).
4. Turn the feedback potentiometer shaft(6) with a screw driver until you read 3.7 - 3.9 mA on the meter.

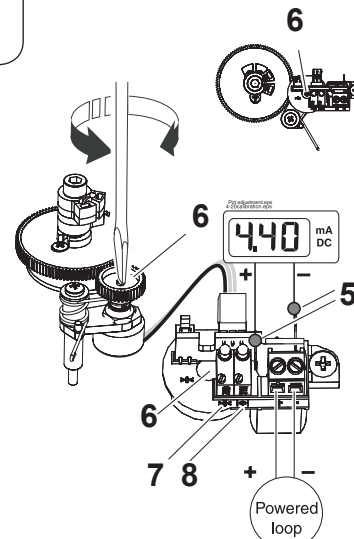

5. Adjust the trim potentiometer(7) marked zero so that the meter reads 4mA.
6. Set the valve/actuator to the open position (20mA).
7. Adjust the trim potentiometer(8) marked span until the meter reads 20mA.
8. Re-check the zero position (4mA) and make fine adjustments if necessary.

A very basic calibration can be accomplished without a meter, using the two LED's.

Red LED lights up below 3.9mA, Green LED lights up above 20.1mA.

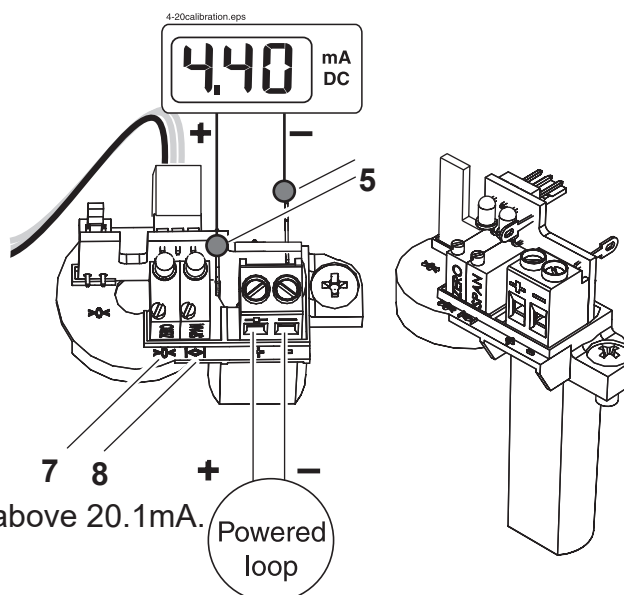

2.3.6 Trouble shooting - Reset and Calibration

If you are unable to properly zero and span the feedback, the potentiometers could be out of factory settings. In order to get back to factory settings please follow the steps 1-8 below.

NOTE: Make sure V200E/P has first been properly calibrated!

1. Turn the ZERO-pot(2) more than 22 turns counter clockwise.
2. Turn the ZERO-pot(2) 5-6 turns clockwise.
3. Turn the SPAN-pot(3) more than 22 turns counter clockwise.
4. Turn the SPAN-pot(3) 10-12 turns clockwise.
5. Turn the FEEDBACK-pot(1) until 3.7-3.9 mA is achieved.
6. Adjust the ZERO-pot(2) clockwise to 4mA.
7. Open the valve.
8. Adjust the SPAN-pot(3) to 20mA.
9. Close the valve.
10. Repeat (steps 6-9) until the unit is properly set.

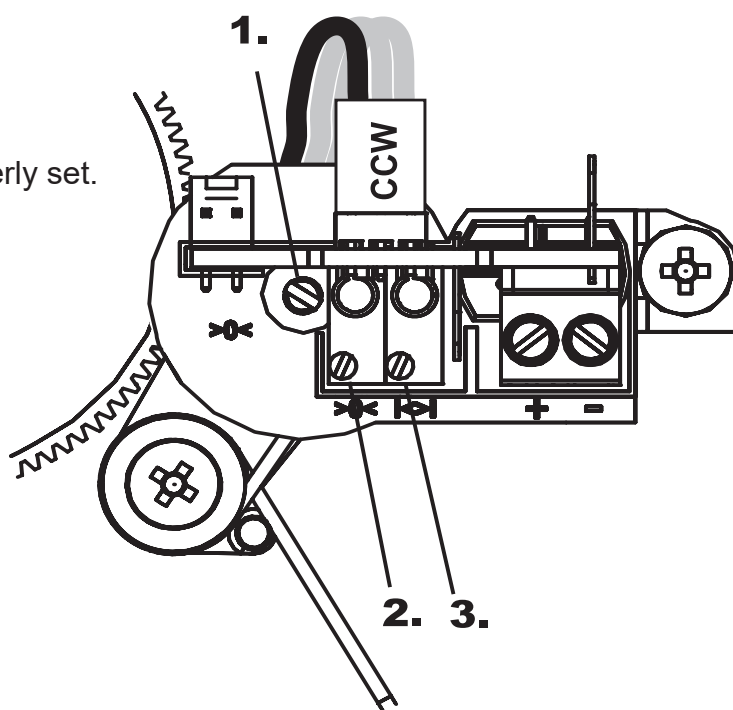



V200 POSITIONER

www.vacaccessories.com

2.4 Switch option Installation

2.4.1 Switch and cam installation

1. Remove the front cover and indicator on the V200 positioner. (see page 4)
2. Remove the Indicator screw(1).
3. Install the switch cam assembly(2) in the positioner drive slot and secure the cams with screw(3). Install the switch module(4) and tighten the three screws(5).

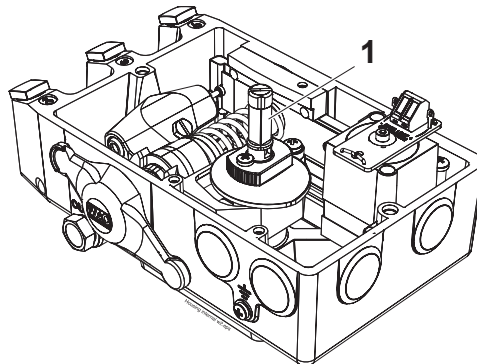

2.4.2 Electrical installation

Connect your control system/equipment cables to the terminal blocks(6)
Maximum cable size AWG 11(4 mm²)

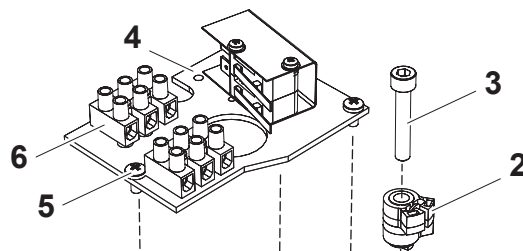

2.4.3 Switch calibration

The switch activating points can be adjusted by turning the friction loaded cams(7,8) using a screwdriver in the slots on the cams.

1. With a meter, set the first cam to either normally open(NO) or normally closed(NC) at its desired position.
2. Stroke the valve/actuator to the desired position for the second switch and adjust the second cam.
3. Double check the two activation points.

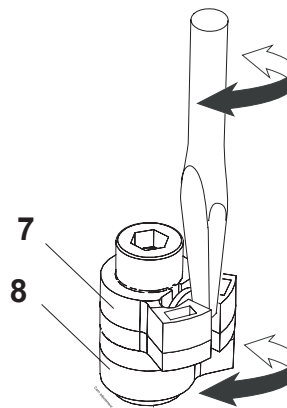
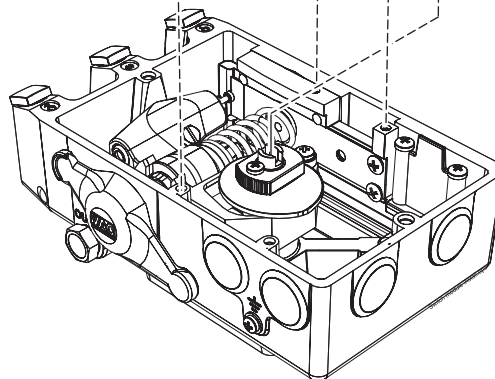

NOTE: Use a non magnetic screwdriver when adjusting reed switch cams!

3. SPARE PARTS

3.1 Exploded drawing Feedback options

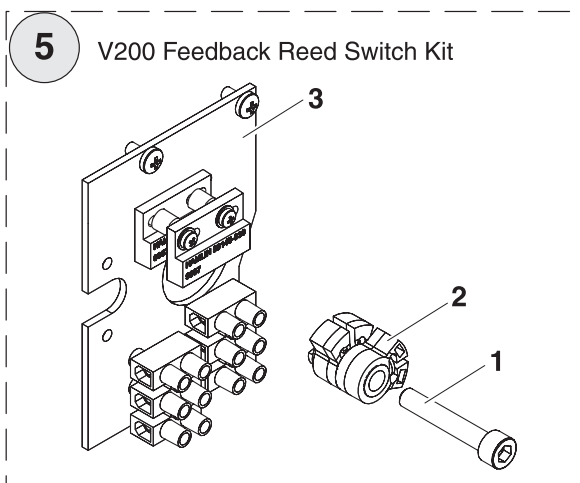
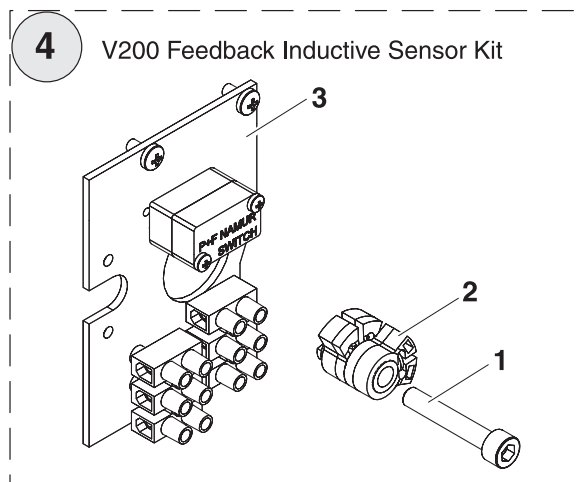
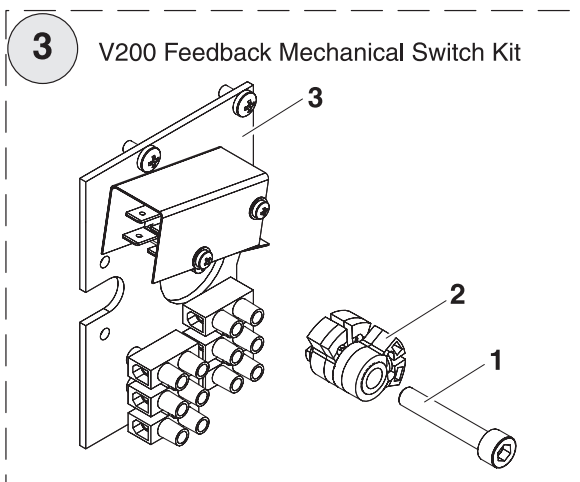
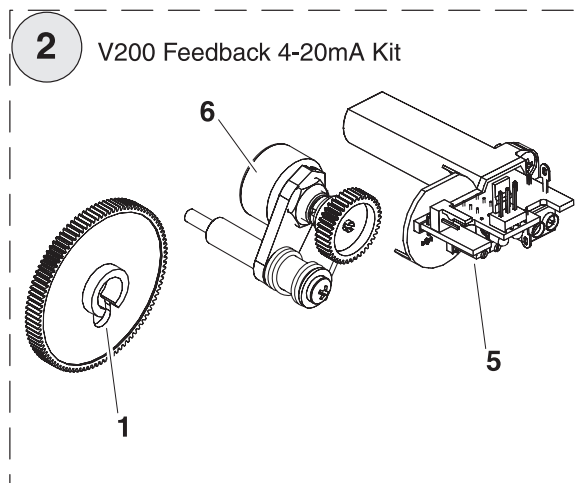
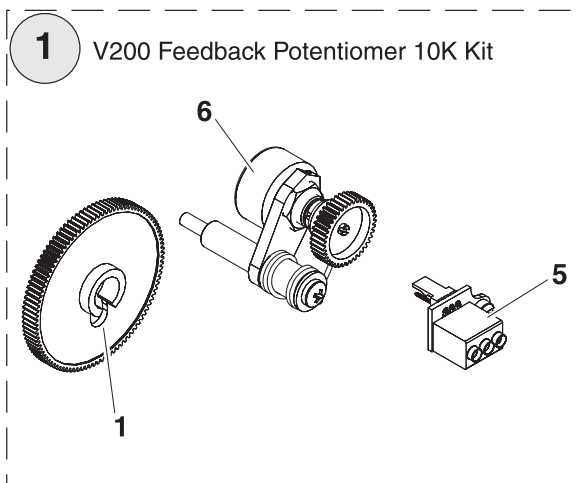

Combination of kits

V200 Feedback Mechanical Switch + 4-20mA Kit

$$6 = 2 + 3$$

V200 Feedback Inductive Sensor + 4-20mA Kit

$$7 = 2 + 4$$

V200 Feedback Reed Switch + 4-20mA Kit

$$8 = 2 + 5$$



V200 POSITIONER

www.vacaccessories.com

3.2 Spare parts list Feedback options

Item	Description	Material	Part no	Qty	Item	Description	Material	Part no	Qty
1	V200 Feedback Potentiometer 10K Kit		93006	1	4	V200 Feedback Inductive Sensor Kit		93014	1
(1	V200 Feedback Potentiometer 5K Kit		93028	1)	1	Screw ISO 4762 M6x35	Stainless Steel	4762063535	1
(1	V200 Feedback Potentiometer 1K Kit		93047	1)	2	Switch Cam Module Inductive Sensor		93022	1
1	Gearwheel 100-M0,5	Plastic <PA>	90116	1		Switch Shaft	Zink	90155	1
5	Terminal Block, Potentiometer		91015	1		Switch Cam mkll	Zink	90157	2
	- Screw ISO 7045 MRX4x8-4	Stainless Steel	7045040804	1		Switch Cam Clip mkll	Stainless Steel	90158	2
6	Potentiometer Module 10K		93010	1		Steel Pin 4x2	Steel		2
(6	Potentiometer Module 5K (Optional)		93030	1)	3	Switch Module Inductive Sensor (NAMUR)		93025	1
(6	Potentiometer Module 1K (Optional)		93031	1)		Switch Plate	Aluminum	90118	1
	Pot Arm mkll	Zink	90097	1		Inductive Sensor NJ2-V3-N (NAMUR)		NJ2-V3_N	2
	Potentiometer 6186 R10K L1,0		6186R10K	1		Terminal Block, 3 Terminals		92064	2
	Potentiometer 6186 R5K L1,0 (Optional)		6186R5K	1		Spacer DRN 3260x7.5	Plastic <PA>	3260075	2
	Potentiometer 6186 R1K L1,0 (Optional)		6186R1K	1		Screw ISO 7045 MRX3x12	Steel Zinc plated	7045031212	2
	Gearwheel 40-M0,5	Plastic <PA>	90115	1		Screw ISO 7045 MRX3x20	Steel Zinc plated	7045032020	2
	Tube spacer gear wheel		90119	1		Screw ISO 7045 MRX3x25	Steel Zinc plated	7045032525	2
	Circlip Gearwheel	Stainless Steel	90067	1		Screw ISO 7045 MRX4x8-4	Stainless Steel	7045040804	3
	Pot Spring coil	Stainless Steel	90184	1	5	V200 Feedback Reed Switch Kit		93005	1
	Shaft mkll Pot Arm	Stainless Steel	90123	1	1	Screw ISO 4762 M6x35	Stainless Steel	4762063535	1
	Screw ISO 7045 MRX4x50	Stainless Steel	7045045050	1	2	Switch Cam Module Reed		93021	1
	Washer ISO 7089-4	Stainless Steel	70894	1		Switch Shaft	Zink	90155	1
	Flat cable with connector	Plastic, brass, rubber	92114	1		Switch Cam mkll	Zink	90157	2
2	V200 Feedback 4-20mA Kit		93007	1		Switch Cam Clip mkll	Stainless Steel	90158	2
1	Gearwheel 100-M0,5	Plastic <PA>	90116	1		Magnet Neodym Ø4x2	Neodym	43-0940-10	2
5	4-20 mA module mkll		93123	1	3	Switch Module Reed Switch		93024	1
	- Screw ISO 7045 MRX4x8-4	Stainless Steel	7045040804	1		Switch Plate	Aluminum	90118	1
6	Potentiometer Module 10K		93010	1		Reed Switch Hamlin		59145 3S02A	2
	Pot Arm mkll	Zink	90097	1		Spacer DRN 3260x7.5	Plastic <PA>	3260075	2
	Potentiometer 6186 R10K L1,0		6186R10K	1		Spacer DRM 3260x2	Brass Ni plated	326002	2
	Gearwheel 40-M0,5	Plastic <PA>	90115	1		Spacer DRN 3260x6	Brass Ni plated	326006	2
	Tube spacer gear wheel		90119	1		Terminal Block, 3 Terminals		92064	2
	Circlip Gearwheel	Stainless Steel	90067	1		Screw ISO 7045 MRX3x12	Steel Zinc plated	7045031212	2
	Pot Spring coil	Stainless Steel	90184	1		Screw ISO 7045 MRX3x20	Steel Zinc plated	7045032020	4
	Shaft mkll Pot Arm	Stainless Steel	90123	1		Screw ISO 7045 MRX4x8-4	Stainless Steel	7045040804	3
	Screw ISO 7045 MRX4x50	Stainless Steel	7045045050	1		Washer ISO 7093-3	Stainless Steel	709303	2
	Washer ISO 7089-4	Stainless Steel	70894	1	6	V200 Feedback Mech+4-20mA Kit		93011	1
	Flat cable with connector	Plastic, brass, rubber	92114	1	3	V200 Feedback Mechanical Switch Kit		93004	1
3	V200 Feedback Mechanical Switch Kit		93004	1	2	V200 Feedback 4-20mA Kit		93007	1
1	Screw ISO 4762 M6x35	Stainless Steel	4762063535	1	7	V200 Feedback Inductive Sensor +4-20mA Kit		93015	1
2	Switch Cam Module Mech		93020	1	4	V200 Feedback Inductive Sensor Kit		93014	1
	Switch Shaft	Zink	90155	1	2	V200 Feedback 4-20mA Kit		93007	1
	Switch Cam mkll	Zink	90157	2	8	V200 Feedback Reed+4-20mA Kit		93012	1
	Switch Cam Clip mkll	Stainless Steel	90158	2	5	V200 Feedback Reed Switch Kit		93005	1
3	Switch Module Mechanical Switch		93023	1	2	V200 Feedback 4-20mA Kit		93007	1
	Switch Plate	Aluminum	90118	1					
	Micro Switch V3 Camden		CMNS 2020D	2					
	Protection Plate V3	Plastic <PA>	90086	1					
	Terminal block, 3 terminals		92064	2					
	Spacer DRN 3260x7.5	Plastic <PA>	3260075	2					
	Screw ISO 7045 MRX3x12	Steel Zinc plated	7045031212	2					
	Screw ISO 7045 MRX3x20	Steel Zinc plated	7045032020	2					
	Screw ISO 7045 MRX3x25	Steel Zinc plated	7045032525	2					
	Screw ISO 7045 MRX4x8-4	Stainless Steel	7045040804	3					
	Washer ISO 7093-3	Stainless Steel	709303	2					
	Cable Blue AWG 16 L = 8"		92066	2					
	Cable Black AWG 16 L = 8"		92067	2					
	Cable Brown AWG 16 L = 8"		92068	2					



4. SPECIFICATIONS

4.1 Specifications feedback options

Mechanical Switch module

Type: SPDT, V3 (Camden CMNS 2020D)

Maximum load:

Resistive	(Inductive)	Voltage
10 A	(3) A	250 VAC

Reed Switch module

Type: SPDT-CO, Form C (Hamlin 59145-3S02A)

Contact rating: max 3W

Voltage switching: max 175 VDC

Voltage breakdown: min 200 VDC

Current switching max 0.25 A

Current carry max 1.5 A

Contact resistance: 0.2 Ohm

Contact capacitance: 0.3 pF

Mechanical and electrical life: Over 100 million operations.

Inductive Sensors (NAMUR) module

Type: NAMUR 2-wire, V3 (P+F NJ2-V3-N)

Power supply: 5-25 VDC, 2-wire

Output signal: Target absent (off) >3mA (15mA max.)

Target present (on) <1mA

Hysteresis: 3-15% (5% typical)

Repeatability: <.01mm

Operating temperature: -14 to +212°F (-10 to +100°C)

4-20mA Position Transmitter module

Voltage supply: 7-30 VDC

Output: 4-20mA, 2 wire

Loop Impedance: max 850 Ohm @ 24 VDC

Linearity error: <1.2%

Hysteresis: <0.2%

Temperature sensitivity: <0.1%/10°F (5.5°C)

Potentiometer module

Output: 10k Ohm (5k Ohm or 1k Ohm optional)

Resistive element: Conductive plastic

Power rating: 1W @ 158°F (70°C)

Linearity error: <1%

Resolution: Infinity



VALVE ACCESSORIES & CONTROLS

200 Jade Park

Chelsea, AL 35043

TEL: (1) 205-678 0507

FAX: (1) 205-678-0510

info@vacaccessories.com

www.vacaccessories.com



Designed and manufactured in Sweden by:
VAC, VALVE ACCESSORIES & CONTROLS SWEDEN AB
Box 580, SE-175 26 JÄRFÄLLA • Girovägen 13, SE-175 62 JÄRFÄLLA
Tel: +46 (0)8 568 200 50 • Fax: +46 (0)8 580 361 35
info@vac.se • www.vac.se

ISO 9001

BUREAU VERITAS
Certification

