

# Helios Large Display Analog Input Batch Controller

## Instruction Manual

PD2-6210



# HELIOS



## Batch Controller

- Large 1.80" Digits
- Dual-Line 6-Digit Display
- Readable from up to 100 Feet (30 Meters) Away
- Superluminous Sunlight Readable Display
- NEMA 4X, IP65 Rated Field Mountable Enclosure
- Operating Temperature Range of -40 to 65°C (-40 to 150°F)
- Single or Multi-Stage Batch Control (up to 4 Relays)
- 0-20 mA, 4-20 mA, 0-5 V, 1-5 V, and  $\pm 10$  V Inputs
- Input Power Options Include 85-265 VAC or 12-24 VDC
- Isolated 24 VDC Transmitter Power Supply
- Start/Pause/Stop, Change Batch with Front Panel Buttons
- Automatic Overrun Correction
- Count Up or Down with Each Batch
- 2 or 4 Relays + Isolated 4-20 mA Output Options
- Onboard USB & RS-485 Serial Communications
- Modbus<sup>®</sup> RTU Communication Protocol Standard
- Program the Meter from a PC with onboard USB and MeterView Pro

## Precision Digital Corporation

233 South Street • Hopkinton MA 01748 USA  
Tel (800) 343-1001 • Fax (508) 655-8990

# PRECISION DIGITAL

[www.predig.com](http://www.predig.com)

## Disclaimer

The information contained in this document is subject to change without notice. Precision Digital makes no representations or warranties with respect to the contents hereof and specifically disclaims any implied warranties of merchantability or fitness for a particular purpose.

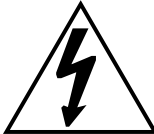
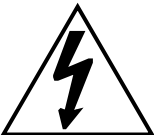
|   |  |
|---|--|
|                                |    |
| <p><b>Caution:</b> <i>Read complete instructions prior to installation and operation of the controller.</i></p> | <p><b>Warning:</b> <i>Risk of electric shock or personal injury.</i></p>   |
|                                | <p><b>Warning!</b> <i>This product is not recommended for life support applications or applications where malfunctioning could result in personal injury or property loss. Anyone using this product for such applications does so at their own risk. Precision Digital Corporation shall not be held liable for damages resulting from such improper use.</i></p> |

## Limited Warranty

Precision Digital Corporation warrants this product against defects in material or workmanship for the specified period under “Specifications” from the date of shipment from the factory. Precision Digital’s liability under this limited warranty shall not exceed the purchase value, repair, or replacement of the defective unit.

## Registered Trademarks

MeterView® Pro is a registered trademark of Precision Digital Corporation. All other trademarks mentioned in this document are the property of their respective owners.

© 2018 Precision Digital Corporation. All rights reserved.

**[www.predig.com](http://www.predig.com)**

## Table of Contents

|   |    |   |    |
|---|----|---|----|
| Table of Contents .....   | 3  | Setting Batch Control Relays .....  | 40 |
| Table of Figures .....  | 4  | Programming Set and Reset Points .....  | 41 |
| Introduction .....  | 4  | Setting Fail-Safe Operation .....   | 41 |
| Ordering Information .....  | 5  | Programming Time Delay .....  | 41 |
| Specifications .....  | 5  | Relay Action for Loss of 4-20 mA Input (Loop Break) .....   | 41 |
| General .....   | 5  | Relay and Alarm Operation Diagrams .....  | 42 |
| Process Input .....   | 6  | High Alarm Operation (Set > Reset) .....  | 42 |
| Batch Controller Rate/Totalizer Display .....   | 6  | Low Alarm Operation (Set < Reset) .....   | 42 |
| Relays .....  | 7  | High Alarm with Fail-Safe Operation (Set > Reset) .....   | 42 |
| Isolated 4-20 mA Transmitter Output .....   | 7  | Low Alarm with Fail-Safe Operation (Set < Reset) .....  | 42 |
| RS485 Serial Communications Terminal .....  | 8  | Relay Sampling Operation .....  | 42 |
| Modbus® RTU Serial Communications .....   | 8  | Total Relay Sampling Operation .....  | 43 |
| Digital Input & Output Terminal .....   | 8  | Signal Loss or Loop Break Relay Operation .....   | 43 |
| Compliance Information .....  | 9  | Time Delay Operation .....  | 43 |
| Safety .....  | 9  | Relay Operation Details .....   | 44 |
| Safety Information .....  | 10 | Overview .....  | 44 |
| Installation .....  | 10 | Relays Initialization .....   | 44 |
| Unpacking .....   | 10 | Fail-Safe Operation .....   | 44 |
| Wall Mounting Instructions .....  | 11 | Front Panel LEDs .....  | 44 |
| Pipe Mounting Instructions .....  | 12 | Automatic Reset (R <sub>u</sub> t <sub>o</sub> ) .....  | 45 |
| Transmitter Supply Voltage Selection (P+, P-) .....   | 13 | Pump Alternation Control Applications (R <sub>L</sub> t <sub>E</sub> r <sub>n</sub> ) .....                         | 45 |
| Connections .....   | 13 | Setting up the Interlock Relay (Force On) Feature .....   | 45 |
| Connectors Labeling .....   | 14 | Sample Relay Operation .....  | 46 |
| Power Connections .....   | 14 | Scaling the 4-20 mA Analog Output (R <sub>o</sub> u <sub>t</sub> ) .....  | 46 |
| Signal Connections .....  | 15 | Reset Menu (r <sub>E</sub> S <sub>E</sub> t) .....  | 46 |
| Modbus RTU Serial Communications .....  | 16 | Control Menu (C <sub>o</sub> n <sub>t</sub> r <sub>L</sub> ) .....  | 46 |
| Relay Connections .....   | 16 | Setting up the Password (P <sub>R</sub> 55) .....   | 47 |
| Switching Inductive Loads .....   | 17 | Protecting or Locking the Meter .....   | 47 |
| RS485 Output Connections .....  | 18 | Total Reset Password & Non-Resettable Total .....   | 47 |
| Digital I/O Connections .....   | 20 | Making Changes to a Password Protected Meter .....  | 48 |
| F4 Digital Input Connections .....  | 20 | Disabling Password Protection .....   | 48 |
| 4-20 mA Output Connections .....  | 21 | Advanced Operation and Programming .....  | 49 |
| Analog Output Transmitter Power Supply .....  | 21 | Function Keys Operation .....   | 49 |
| Interlock Relay Feature .....   | 21 | Digital Input Operation .....   | 49 |
| Basic Operation and Programming .....   | 22 | Advanced Setup and Calibration .....  | 49 |
| Overview .....  | 22 | Multi-Point Calibration & Scaling .....   | 49 |
| Programming Buttons and Status LED Indicators .....   | 23 | Maximum/Minimum Readings .....  | 49 |
| MeterView® Pro Software .....   | 24 | Advanced Features Menu .....  | 50 |
| MeterView Pro Installation .....  | 24 | Advanced Features Menu & Display Messages .....   | 50 |
| Controller Operation .....  | 25 | Noise Filter (F <sub>i</sub> l <sub>t</sub> E <sub>r</sub> ) .....  | 52 |
| Default Batch Control Operation .....   | 25 | Noise Filter Bypass (b <sub>y</sub> P <sub>R</sub> 55) .....  | 52 |
| Batch Control Operation Example .....   | 26 | Rounding Feature (r <sub>o</sub> u <sub>n</sub> d) .....  | 52 |
| Display Functions & Messages .....  | 28 | Modbus RTU Serial Communications (S <sub>E</sub> r <sub>i</sub> a <sub>L</sub> ) .....                              | 52 |
| Main Menu .....   | 31 | Select Menu (S <sub>E</sub> L <sub>E</sub> c <sub>t</sub> ) .....   | 53 |
| Setting Numeric Values .....  | 31 | Signal Input Conditioning (F <sub>u</sub> n <sub>c</sub> t <sub>i</sub> o <sub>n</sub> ) .....                      | 53 |
| Setting up the Batch Controller (S <sub>E</sub> t <sub>u</sub> p) .....   | 32 | Low-Flow Cutoff (L <sub>o</sub> w <sub>F</sub> l <sub>o</sub> w <sub>C</sub> u <sub>t</sub> o <sub>f</sub> f) ..... | 54 |
| Setting the Input Signal (i <sub>n</sub> P <sub>u</sub> t) .....  | 32 | Total and Grand Total Count Direction (C <sub>o</sub> u <sub>n</sub> t) .....                                       | 54 |
| Setting the Totalizer and Batching Features (t <sub>o</sub> t <sub>a</sub> l <sub>i</sub> z <sub>e</sub> r) ..... | 32 | Analog Output Programming (R <sub>o</sub> u <sub>t</sub> P <sub>r</sub> ) .....                                     | 54 |
| Setting the Input Units or Custom Tags (u <sub>n</sub> i <sub>t</sub> s) .....                                    | 33 | Programmable Function Keys User Menu (u <sub>s</sub> E <sub>r</sub> ) .....   | 54 |
| Setting the Decimal Point (d <sub>E</sub> c <sub>P</sub> t) .....   | 33 | Internal Source Calibration (i <sub>L</sub> R <sub>L</sub> ) .....  | 56 |
| Programming the Batch Controller (P <sub>r</sub> o <sub>G</sub> ) .....   | 34 | Troubleshooting .....   | 57 |
| Setting the Display Parameter & Intensity (d <sub>5</sub> P <sub>L</sub> R <sub>5</sub> ) .....                   | 38 | Diagnostics Menu (d <sub>i</sub> a <sub>G</sub> n <sub>o</sub> s <sub>t</sub> i <sub>c</sub> s) .....               | 57 |
| Setting the Relay Operation (r <sub>E</sub> L <sub>A</sub> y) .....   | 39 | Determining Software Version .....  | 57 |
| Relay Assignment (R <sub>5</sub> 5 <sub>i</sub> n) .....  | 40 | Reset Controller to Factory Defaults .....  | 57 |
| Setting the Relay Action .....  | 40 | Factory Defaults & User Settings .....  | 58 |
|   |    | Troubleshooting Tips .....  | 60 |

## Table of Figures

|  |    |  |    |
|--|----|--|----|
| Figure 1. Meter Mounting Holes.....                                | 11 | Figure 11. Voltage Input Connections .....                           | 16 |
| Figure 2. Controller Dimensions - Side View .....                  | 11 | Figure 12. Relay Connections .....                                   | 16 |
| Figure 3. Controller Dimensions – Front View .....                 | 11 | Figure 13. AC and DC Loads Protection .....                          | 17 |
| Figure 4. Vertical Pipe Mount Assembly .....                       | 12 | Figure 14. Low Voltage DC Loads Protection .....                     | 17 |
| Figure 5. Horizontal Pipe Mount Assembly.....                      | 12 | Figure 15. RS-422 or RS-485 Wiring.....                              | 18 |
| Figure 6. Transmitter Supply Voltage Selection.....                | 13 | Figure 16. RS-485 Two-Wire Multi-Drop Wiring ...                     | 19 |
| Figure 7. Connector Labeling for Fully Loaded PD2-6210 .....       | 14 | Figure 17. Connections for RS485 Connector to Serial Converter ..... | 19 |
| Figure 8. Power Connections.....                                   | 14 | Figure 18. Three-Wire RS485 Connection .....                         | 19 |
| Figure 9. Transmitters Powered by Internal Supply .....            | 15 | Figure 19. Digital Input and Output Connections .                    | 20 |
| Figure 10. Transmitter Powered by Ext. Supply or Self-Powered..... | 15 | Figure 20. F4 Digital Input Connections .....                        | 20 |
|  |    | Figure 21. 4-20 mA Output Connections .....                          | 21 |
|  |    | Figure 22. Interlock Connections .....                               | 21 |

## Introduction

The Helios PD2-6210 is a multi-purpose, easy to use, large-display batch controller ideal for simplifying independent batch control operations where local control is preferred to expensive and expansive plant operation systems. It features large 1.8 superluminous inch LED digits, which can be read in sunlight from up to 100 feet away. It is housed in a water-resistant, field mountable NEMA 4X/IP65 rated enclosure for convenient indoor and outdoor installation.

The controller comes programmed for easy start, pause, stop, and batch size (preset) changes. Display line two (2) can be programmed to display rate, grand total, batch count, or preset by cycling the Stop (F3) button. Digital inputs come standard.

Single and multi-stage batching is possible with up to four (4) on-board relays. Each batch control relay may have a unique preclose amount when used for multi-stage batching. Manual start batching is default, but automatic batching with a restart after a programmed time delay from the completion of the last batch is also possible.

Overrun correction adjusts the closing of the batch control relays to adjust for inaccuracies from batch to batch. This increases accuracy over time as systems wear out. The overrun correction feature is capable of compensating for inaccuracies of up to 10% of the programmed preset value.

The controller accepts current and voltage signals (e.g. 4-20 mA, 0-10 V). Three of the programming buttons can be set for custom operation. A fully loaded PD2-6210 batch controller comes with four (4) SPDT relays, a 4 20 mA output, two 24 VDC power supplies, five (5) digital inputs and four (4) digital outputs, and RS485 serial communications, making it an excellent addition to any system.

## Ordering Information

### Standard Models

| 85-265 VAC Model | 12-24 VDC Model | Options Installed         |
|------------------|-----------------|---------------------------|
| PD2-6210-6H2     | PD2-6210-7H2    | 2 Relays                  |
| PD2-6210-6H7     | PD2-6210-7H7    | 4 relays & 4-20 mA output |

### Accessories

| Model     | Description   |
|-----------|---|
| PDA6260   | Pipe Mounting Kit   |
| PDA7485-I | RS-232 to RS-422/485 isolated converter                   |
| PDA7485-N | RS-232 to RS-422/485 non-isolated converter               |
| PDAPLUG2  | Plastic Conduit Plug                                      |
| PDX6901   | Suppressor (snubber): 0.01 $\mu$ F/470 $\Omega$ , 250 VAC |

## Specifications

Except where noted all specifications apply to operation at +25°C.

### General

|                            |   |
|----------------------------|---|
| <b>Display</b>             | Main display: 1.8" (46 mm) high, red LEDs<br>6 digits per line (-99999 to 999999), with lead zero blanking  |
| <b>Display Intensity</b>   | Eight user selectable intensity levels  |
| <b>Display Update Rate</b> | 5/second (200 ms)   |
| <b>Overrange</b>           | Display flashes 999999  |
| <b>Underrange</b>          | Display flashes -99999  |
| <b>Display Assignment</b>  | Display lines 1 & 2 may be assigned to rate, total, grand total, batch count, preset, set points, units (lower display only), alternating R & T, R & GT, preset & rate, max & min, or a Modbus display register. Any rate/total/grand total display may be programmed to alternate with a custom unit or tag. |
| <b>Alternating Display</b> | Displays alternate every 10 seconds when display is selected or batch is paused.  |
| <b>Programming Methods</b> | Four programming buttons, digital inputs, PC and MeterView Pro software, or Modbus registers.   |
| <b>Noise Filter</b>        | Programmable from 2 to 199 (0 will disable filter)  |
| <b>Filter Bypass</b>       | Programmable from 0.1 to 99.9% of calibrated span   |
| <b>Recalibration</b>       | All ranges are calibrated at the factory. Recalibration is recommended at least every 12 months.  |

|  |  |
|--|--|
| <b>Max/Min Display</b>                   | Max/min readings reached by the process are stored until reset by the user or until power to the controller is turned off.   |
| <b>Password</b>                          | Three programmable passwords restrict modification of programmed settings.<br>Pass 1: Allows use of function keys and digital inputs<br>Pass 2: Allows use of function keys, digital inputs and editing set/reset points<br>Pass 3: Restricts all programming, function keys, and digital inputs<br>Total: Prevents resetting the total manually<br>Gtotal: Prevents resetting the grand total manually. |
| <b>Power Options</b>                     | 85-265 VAC 50/60 Hz, 90-265 VDC, 20 W max or 12-24 VDC $\pm$ 10%, 15 W max<br>Powered over USB for configuration only.   |
| <b>Isolated Transmitter Power Supply</b> | Terminals P+ & P-: 24 VDC $\pm$ 10%.<br>12-24 VDC powered models selectable for 24, 10, or 5 VDC supply (internal P+/P- switch).<br>85-265 VAC models rated @ 200 mA max, 12-24 VDC powered models rated @ 100 mA max, @ 50 mA max for 5 or 10 VDC supply.   |
| <b>Non-Volatile Memory</b>               | All programmed settings are stored in non-volatile memory for a minimum of ten years if power is lost.   |

|                              |  |
|------------------------------|--|
| <b>Fuse</b>                  | Required external fuse: UL Recognized, 5 A max, slow blow; up to 6 controllers may share one 5 A fuse  |
| <b>Normal Mode Rejection</b> | Greater than 60 dB at 50/60 Hz   |
| <b>Isolation</b>             | 4 kV input/output-to-power line; 500 V input-to-output or output-to-P+ supply  |
| <b>Overvoltage Category</b>  | Installation Overvoltage Category II:<br>Local level with smaller transient overvoltages than Installation Overvoltage Category III.   |
| <b>Environmental</b>         | Operating temperature range: -40 to 150°F (-40 to 65°C)<br>Storage temperature range: -40 to 185°F (-40 to 85°C)<br>Relative humidity: 0 to 90% non-condensing   |
| <b>Connections</b>           | Removable and integrated screw terminal blocks accept 12 to 22 AWG wire.   |
| <b>Enclosure</b>             | UL Type 4X, IP65 rated. Polycarbonate & glass blended plastic case, color: gray. Includes four PG11 through-hole conduit openings, with two factory installed PG11, IP68, black nylon threaded hole plugs with backing nuts.   |
| <b>Mounting</b>              | <b>Wall Mounting:</b> Four (4) mounting holes provided for screwing controller into wall. See Wall Mounting Instructions on page 11 for additional details.<br><b>Pipe Mounting:</b> Optional pipe mounting kit (PDA6260) allows for pipe mounting. Sold separately. See Pipe Mounting Instructions on page 12 for additional details. |
| <b>Tightening Torque</b>     | <b>Removable Screw Terminals:</b> 5 lb-in (0.56 Nm)<br><b>Digital I/O and RS485 Terminals:</b> 2.2 lb-in (0.25 Nm)   |
| <b>Overall Dimensions</b>    | 10.63" x 12.59" x 4.77" (270 mm x 319.7 mm x 121.2 mm) (W x H x D)   |
| <b>Weight</b>                | 6.10 lbs (2.76 kg)   |
| <b>Warranty</b>              | 3 years parts & labor  |

**Process Input**

|                 |   |
|-----------------|---|
| <b>Inputs</b>   | Field selectable: 0-20, 4-20 mA, ±10 V (0-5, 1-5, 0-10 V), Modbus PV (Slave)  |
| <b>Accuracy</b> | ±0.03% of calibrated span ±1 count, square root & programmable exponent accuracy<br>range: 10-100% of calibrated span |

|                                      |   |             |                                |         |         |       |        |
|--------------------------------------|---|-------------|--------------------------------|---------|---------|-------|--------|
| <b>Temperature Drift</b>             | 0.005% of calibrated span/°C max from 0 to 65°C ambient, 0.01% of calibrated span/°C max from -40 to 0°C ambient  |             |                                |         |         |       |        |
| <b>Signal Input Conditioning</b>     | Linear, square root, programmable exponent, or round horizontal tank volume calculation   |             |                                |         |         |       |        |
| <b>Multi-Point Linearization</b>     | 2 to 32 points  |             |                                |         |         |       |        |
| <b>Programmable Exponent</b>         | 1.0001 to 2.9999  |             |                                |         |         |       |        |
| <b>Round H Tank</b>                  | Diameter & Length: 999.999 inch or cm calculates volume in gallons or liters respectively.  |             |                                |         |         |       |        |
| <b>Low-Flow Cutoff</b>               | 0-999999 (0 disables cutoff function)   |             |                                |         |         |       |        |
| <b>Decimal Point</b>                 | Up to five decimal places or none: <i>d.ddddd, d.dddd, d.ddd, d.dd, d.d, or d</i>   |             |                                |         |         |       |        |
| <b>Calibration Range</b>             | <table border="1"> <tr> <td>Input Range</td> <td>Minimum Span Input 1 &amp; Input 2</td> </tr> <tr> <td>4-20 mA</td> <td>0.15 mA</td> </tr> <tr> <td>±10 V</td> <td>0.01 V</td> </tr> </table> <p>An error message will appear if the input 1 and input 2 signals are too close together.</p> | Input Range | Minimum Span Input 1 & Input 2 | 4-20 mA | 0.15 mA | ±10 V | 0.01 V |
| Input Range                          | Minimum Span Input 1 & Input 2  |             |                                |         |         |       |        |
| 4-20 mA                              | 0.15 mA   |             |                                |         |         |       |        |
| ±10 V                                | 0.01 V  |             |                                |         |         |       |        |
| <b>Input Impedance</b>               | Voltage ranges: greater than 500 kΩ<br>Current ranges: 50 - 100 Ω (depending on resettable fuse impedance)  |             |                                |         |         |       |        |
| <b>Input Overload</b>                | Current input protected by resettable fuse, 30 VDC max. Fuse resets automatically after fault is removed.   |             |                                |         |         |       |        |
| <b>F4 Digital Input Contacts</b>     | 3.3 VDC on contact. Connect normally open contacts across F4 to COM.  |             |                                |         |         |       |        |
| <b>F4 Digital Input Logic Levels</b> | <b>Logic High:</b> 3 to 5 VDC; <b>Logic Low:</b> 0 to 1.25 VDC  |             |                                |         |         |       |        |

**Batch Controller Rate/Totalizer Display**

|  |   |
|--|---|
| <b>Rate Display Indication</b>               | -99999 to 999999, lead zero blanking. "R" LED illuminates while displaying rate.  |
| <b>Batch Total &amp; Grand Total Display</b> | 0 to 999,999; automatic lead zero blanking. "T" LED is illuminated while displaying batch total. "GT" LEDs are illuminated while displaying grand total. Up to 999,999 for batch total/preset. Up to 999,999,999 with grand total-overflow feature. "OF" is displayed to the left of grand total overflow and ▲ LED is illuminated. |
| <b>Batch Total Decimal Point</b>             | Up to five decimal places or none: <i>d.ddddd, d.dddd, d.ddd, d.dd, d.d, or d</i><br>Total decimal point is independent of rate decimal point.  |



|                                      |  |
|--------------------------------------|--|
| <b>Totalizer</b>                     | Calculates total based on rate and field programmable multiplier to display total in engineering units. Time base must be selected according to the time units in which the rate is displayed.   |
| <b>Grand Totalizer Rollover</b>      | Grand totalizer rolls over when display exceeds 999,999,999. Relay status reflects display.  |
| <b>Grand Total Alarms</b>            | Up to seven, user selectable under setup menu. Any set point can be assigned to grand total and may be programmed anywhere in the range of the controller for grand total alarm indication. Relay 1 should always be assigned to batch.  |
| <b>Programmable Delay On Release</b> | 0.1 and 999.9 seconds; applied to the first relay assigned to total or grand total.<br>If the controller is programmed to reset total to zero automatically when the preset is reached, then a delay will occur before the total is reset.   |
| <b>Grand Total Reset</b>             | Via front panel button, external contact closure on digital inputs, automatically via user selectable preset value and time delay, or through serial communications.   |
| <b>Grand Total Reset Password</b>    | Grand total passwords may be entered to prevent resetting the grand total from the front panel.  |
| <b>Non-Resettable Grand Total</b>    | The grand total can be programmed as a non-resettable total by entering the password "050873".<br><br><div style="display: flex; align-items: center;">  <p><b>Caution!</b> <i>Once the Grand Total has been programmed as "non-resettable" the feature <b>cannot</b> be disabled.</i></p> </div> |
| <b>Relays</b>                        |  |
| <b>Rating</b>                        | 2 or 4 SPDT (Form C) internal and/or 4 SPST (Form A) external; rated 3 A @ 30 VDC and 125/250 VAC resistive load; 1/14 HP (≈ 50 W) @ 125/250 VAC for inductive loads   |
| <b>Noise Suppression</b>             | Noise suppression is recommended for each relay contact switching inductive loads; see page 17 for details.  |
| <b>Deadband</b>                      | 0-100% of span, user programmable  |

|  |   |
|--|---|
| <b>High or Low Alarm</b>                   | User may program any alarm for high or low trip point. Unused alarm LEDs and relays may be disabled (turn off).   |
| <b>Relay Operation</b>                     | Primary Functions:<br>Batch Control<br>Automatic (non-latching) <sup>1</sup><br>Sampling (based on time)<br>Off (disable unused relays and enable Interlock feature)<br>Manual on/off control mode<br>Secondary Functions <sup>2</sup> :<br>Pump alternation control (2 to 4 relays)<br>Latching (requires manual acknowledge)  |
| <b>Relay Reset</b>                         | User selectable via front panel buttons or digital inputs<br><ol style="list-style-type: none"> <li>1. Automatic reset only (non-latching), when the input passes the reset point.</li> <li>2. Automatic + manual reset at any time (non-latching)</li> <li>3. Manual reset only, at any time (latching)</li> <li>4. Manual reset only after alarm condition has cleared (latching)</li> </ol> <p><i>Note: Front panel button or digital input may be assigned to acknowledge relays programmed for manual reset.</i></p> |
| <b>Alarm Time Delay</b>                    | 0 to 999.9 seconds, on & off relay time delays<br>Programmable and independent for each relay   |
| <b>Fail-Safe Operation</b>                 | Programmable and independent for each relay.<br><i>Note: Relay coil is energized in non-alarm condition. In case of power failure, relay will go to alarm state.</i>  |
| <b>Alarm Auto Initialization</b>           | When power is applied to the controller, relays will reflect the state of the input to the controller.  |
| <b>Isolated 4-20 mA Transmitter Output</b> |   |
| <b>Output Source</b>                       | Process variable (PV), max, min, set points 1-8, Modbus input, or manual control mode   |
| <b>Scaling Range</b>                       | 1.000 to 23.000 mA for any display range  |
| <b>Calibration</b>                         | Factory calibrated: 4.000 to 20.000 = 4-20 mA output  |
| <b>Analog Out Programming</b>              | 23.000 mA maximum for all parameters:<br>Overrange, underrange, max, min, and break   |
| <b>Accuracy</b>                            | ± 0.1% of span ± 0.004 mA   |

<sup>1</sup> Alarms are active only when the batch is running.

<sup>2</sup> These operations are not functional when the unit is being used as a batch controller with total set to yes.

|   |  |              |               |
|---|--|--------------|---------------|
| <b>Temperature Drift</b>                            | 0.4 $\mu\text{A}/^\circ\text{C}$ max from 0 to 65 $^\circ\text{C}$ ambient,<br>0.8 $\mu\text{A}/^\circ\text{C}$ max from -40 to 0 $^\circ\text{C}$ ambient<br><i>Note: Analog output drift is separate from input drift.</i> |              |               |
| <b>Isolated Transmitter Power Supply</b>            | Terminals I+ & R: 24 VDC $\pm$ 10%.<br>May be used to power the 4-20 mA output or other devices. Refer to Figure 21 on page 21.<br>All models rated @ 40 mA max.   |              |               |
| <b>External Loop Power Supply</b>                   | 35 VDC maximum   |              |               |
| <b>Output Loop Resistance</b>                       | Power supply   | Minimum      | Maximum       |
|   | 24 VDC   | 10 $\Omega$  | 700 $\Omega$  |
|   | 35 VDC (external)  | 100 $\Omega$ | 1200 $\Omega$ |
| <b>RS485 Serial Communications Terminal</b>         |  |              |               |
| <b>Compatibility</b>                                | EIA-485  |              |               |
| <b>Connectors</b>                                   | Removable screw terminal connector   |              |               |
| <b>Max Distance</b>                                 | 3,937' (1,200 m) max   |              |               |
| <b>Status Indication</b>                            | Separate LEDs for Power (P), Transmit (TX), and Receive (RX)   |              |               |
| <b>Modbus<sup>®</sup> RTU Serial Communications</b> |  |              |               |
| <b>Slave Id</b>                                     | 1 – 247 (Controller address)   |              |               |
| <b>Baud Rate</b>                                    | 300 – 19,200 bps   |              |               |
| <b>Transmit Time Delay</b>                          | Programmable between 0 and 199 ms  |              |               |

|   |  |
|---|--|
| <b>Data</b>   | 8 bit (1 start bit, 1 or 2 stop bits)    |
| <b>Parity</b>   | Even, Odd, or None with 1 or 2 stop bits |
| <b>Byte-To-Byte Timeout</b>   | 0.01 – 2.54 second                       |
| <b>Turn Around Delay</b>  | Less than 2 ms (fixed)                   |
| <i>Note: Refer to the Modbus Register Tables located at <a href="http://www.predig.com">www.predig.com</a> for details.</i> |  |

**Digital Input & Output Terminal**

|                                  |                                      |
|----------------------------------|--------------------------------------|
| <b>Channels</b>                  | 4 digital inputs & 4 digital outputs |
| <b>Digital Input Logic High</b>  | 3 to 5 VDC                           |
| <b>Digital Input Logic Low</b>   | 0 to 1.25 VDC                        |
| <b>Digital Output Logic High</b> | 3.1 to 3.3 VDC                       |
| <b>Digital Output Logic Low</b>  | 0 to 0.4 VDC                         |
| <b>Source Current</b>            | 10 mA maximum output current         |
| <b>Sink Current</b>              | 1.5 mA minimum input current         |

To be used as pull-up for digital inputs only.  
Connect normally open pushbuttons across +5 V & DI 1-4.

**+5 V Terminal**

***DO NOT use +5 V terminal to power external devices.***



## Compliance Information

### Safety

|                              |  |
|------------------------------|--|
| <b>UL &amp; C-UL Listed</b>  | USA & Canada<br>UL 508 Industrial Control Equipment (United States),<br>C22.2 No. 142 (Canadian National Standard) |
| <b>UL File Number</b>        | E160849  |
| <b>Front Panel</b>           | UL Type 4X, NEMA 4X, IP65  |
| <b>Low Voltage Directive</b> | EN 61010-1:2010<br>Safety requirements for measurement, control, and laboratory use                                |

## Safety Information

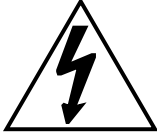
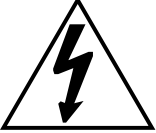
|  |   |
|--|---|
|                         |    |
| <b>Caution:</b> <i>Read complete instructions prior to installation and operation of the controller.</i> | <b>Warning:</b> <i>Risk of electric shock or personal injury.</i>   |
| <br><b>Warning!</b>     | <b>Hazardous voltages exist within enclosure.</b><br><b>Installation and service should be performed only by trained service personnel.</b> |

## Installation

There is no need to open the clear plastic front cover in order to complete the installation, wiring, and setup of the controller. All programming is done through the buttons and switches located under the lower door panel and are accessible by removing the single securing screw. Wires should be run through the knockout holes located on the bottom of the controller.

There are a total of four pre-drilled conduit entry holes located at the bottom of the controller. If the need to drill additional holes arises, make sure you will have the clearance necessary for conduit mounting hardware.

Do not disconnect the RJ45 connector found on the right side of the controller wiring board. Doing so will disable the onboard digital I/O, RS-485 serial communications, and M-Link functionality.

Instructions are provided for changing the transmitter power supply to output 5 or 10 VDC instead of 24 VDC, see page 12.

## Unpacking

Remove the controller from box. Inspect the packaging and contents for damage. Report damages, if any, to the carrier. If any part is missing or the controller malfunctions, please contact your supplier or the factory for assistance.

### Wall Mounting Instructions

The meter can be mounted to any wall using the four provided mounting holes. Note that the bottom mounting holes are located underneath the front door panel. To mount the meter to a wall, follow these instructions.

1. Prepare a section of wall approximately 11" x 13" (280 mm x 330 mm) for controller mounting by marking with a pencil the mounting holes (shown in the image to the right) on the wall.
2. Using a drill bit slightly smaller than the girth of the mounting screws, pre-drill holes at the mounting locations previously marked.
3. Insert mounting screws into the four mounting holes and screw them into the pre-drilled holes. **Do not overtighten** the mounting screws as it is possible that the enclosure could crack and become damaged.

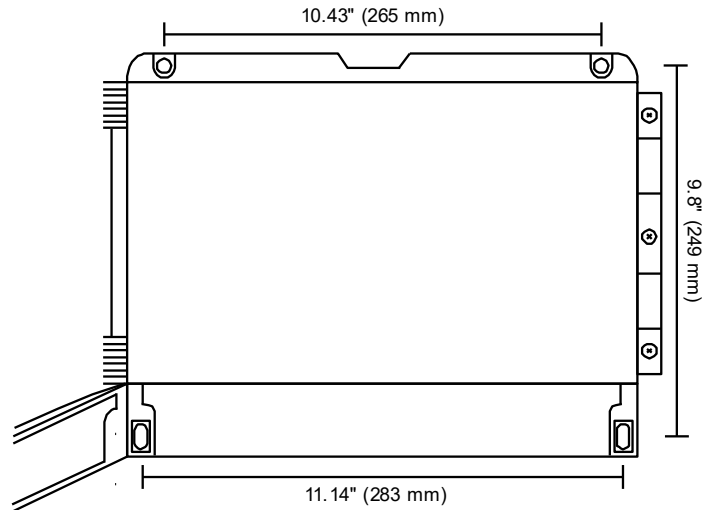

Figure 1. Meter Mounting Holes

### Mounting Dimensions

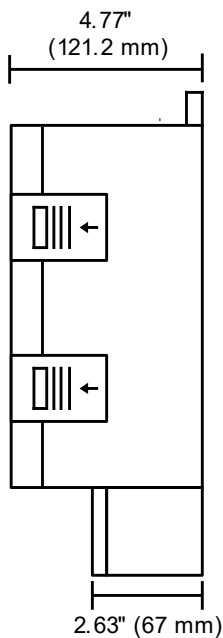

Figure 2. Controller Dimensions - Side View

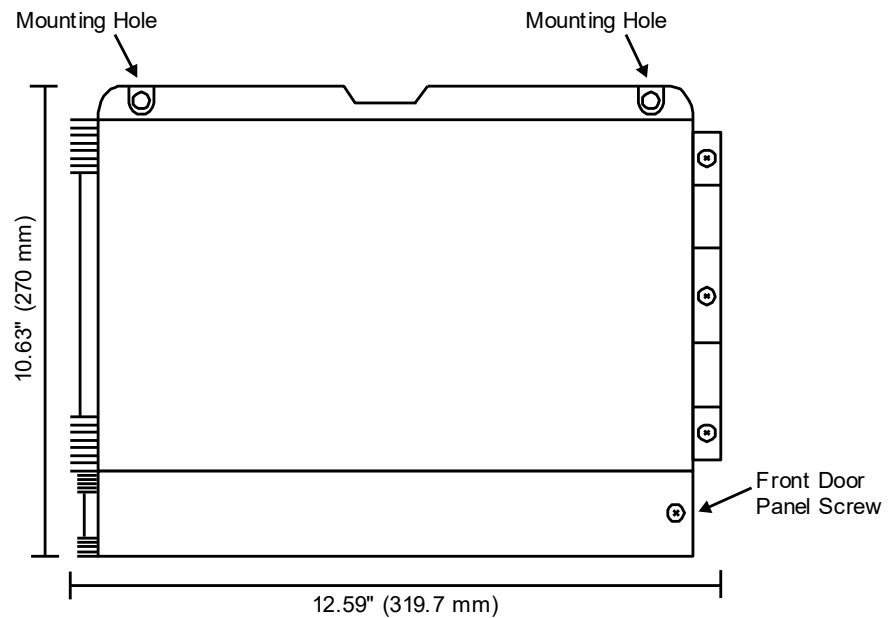
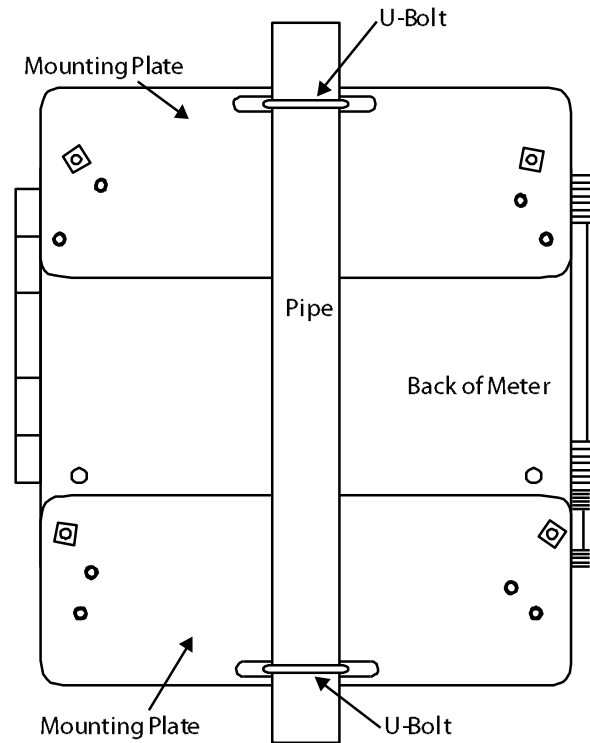

Figure 3. Controller Dimensions – Front View

## Pipe Mounting Instructions

The meter can also be mounted to a pipe using the optional pipe mounting kit (PDA6260). This kit includes two mounting plates, two U-bolts, and the necessary nuts and bolts. To mount the meter to a pipe using the pipe mounting kit accessory, follow these instructions.

1. Secure the mounting plates to the top and bottom (for vertical pipes) or left and right (for horizontal pipes) of the reverse side of the meter enclosure using the provided fasteners. **Do not overtighten** the fasteners as it could cause damage to the enclosure.
2. Using the provided nuts and U-bolts, secure the mounting plates to the pipe enough torque such that the meter cannot be moved up or down (or side to side).



**Figure 4. Vertical Pipe Mount Assembly**

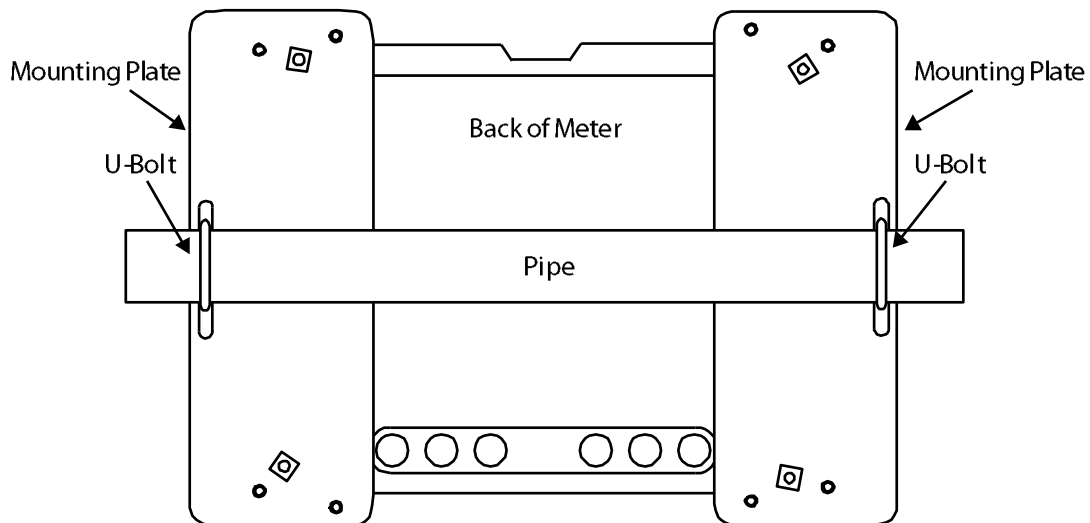

**Figure 5. Horizontal Pipe Mount Assembly**

## Transmitter Supply Voltage Selection (P+, P-)

All meters, including models equipped with the 12-24 VDC power option, are shipped from the factory configured to provide 24 VDC power for the transmitter or sensor.

If the transmitter requires 5 or 10 VDC excitation, the switch labeled P+/P- must be configured accordingly.

To access the voltage selection jumper:

1. Unplug the meter power.
2. Unscrew and open the front door panel.
3. Locate the P+/P- switch located in the center of the connections board (see diagram below).
4. Flip this switch into the appropriate position for the required transmitter excitation.

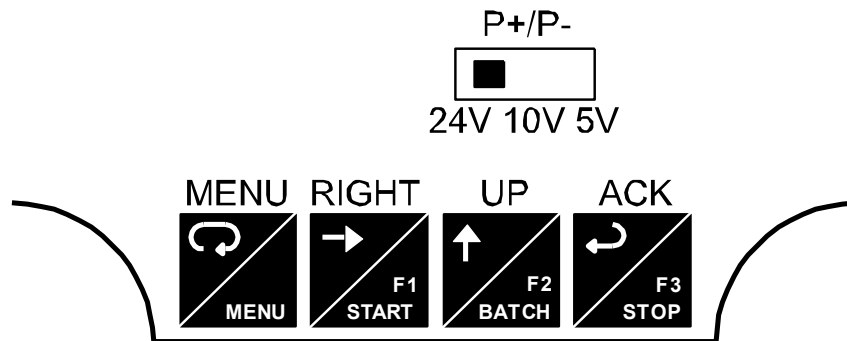

**Figure 6. Transmitter Supply Voltage Selection**

## Connections

All connections are made to screw terminal connectors located under the front door panel. Remove the single securing screw in order to access the wiring terminals.

|   |  |
|---|--|
| <br><b>Caution</b> | <p><i>Use copper wire with 60°C or 60/75°C insulation for all line voltage connections. Observe all safety regulations. Electrical wiring should be performed in accordance with all applicable national, state, and local codes to prevent damage to the meter and ensure personnel safety.</i></p> |
|---|--|

### Connectors Labeling

The connectors' label, affixed to the inside of the lower door panel, shows the location of all connectors available with requested configuration.

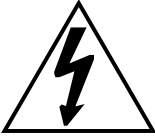
|  |   |
|--|---|
| <br><b>Warning!</b> | <p><b>Do not connect any equipment other than Precision Digital's expansion modules, cables, or meters to the RJ45 M-LINK connector. Otherwise damage will occur to the equipment and the meter.</b></p> <p><b>Do not disconnect the RJ45 connector located to the left of the power terminal block. Doing so will disable the onboard digital I/O, RS-485 serial communications, and M-Link functionality.</b></p> |
|--|---|

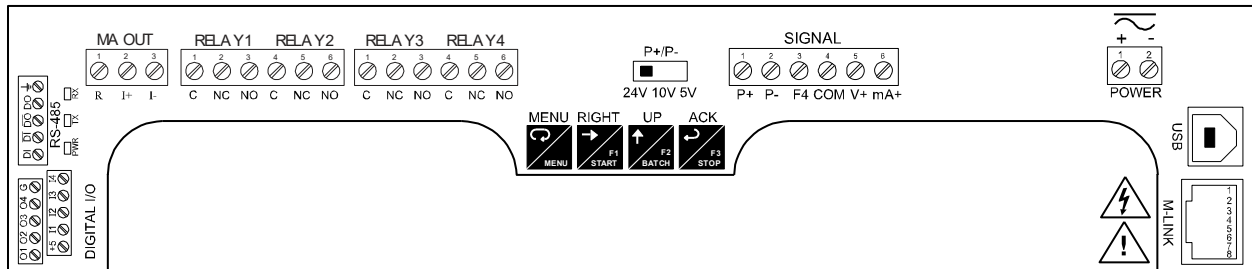

**Figure 7. Connector Labeling for Fully Loaded PD2-6210**

### Power Connections

Power connections are made to a two-terminal connector labeled POWER on Figure 7 on page 14. The meter will operate regardless of DC polarity connection. The + and - symbols are only a suggested wiring convention.

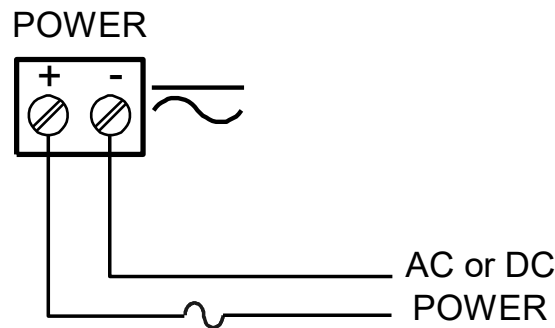

Required External Fuse:  
5 A max, 250 V Slow Blow

**Figure 8. Power Connections**



### Signal Connections

Signal connections are made to a six-terminal connector labeled SIGNAL on Figure 7. The COM (common) terminal is the return for the 4-20 mA and the  $\pm 10$  V input signals.

#### Current and Voltage Connections

The following figures show examples of current and voltage connections.

There are no switches or jumpers to set up for current and voltage inputs. Setup and programming is performed through the front panel buttons.

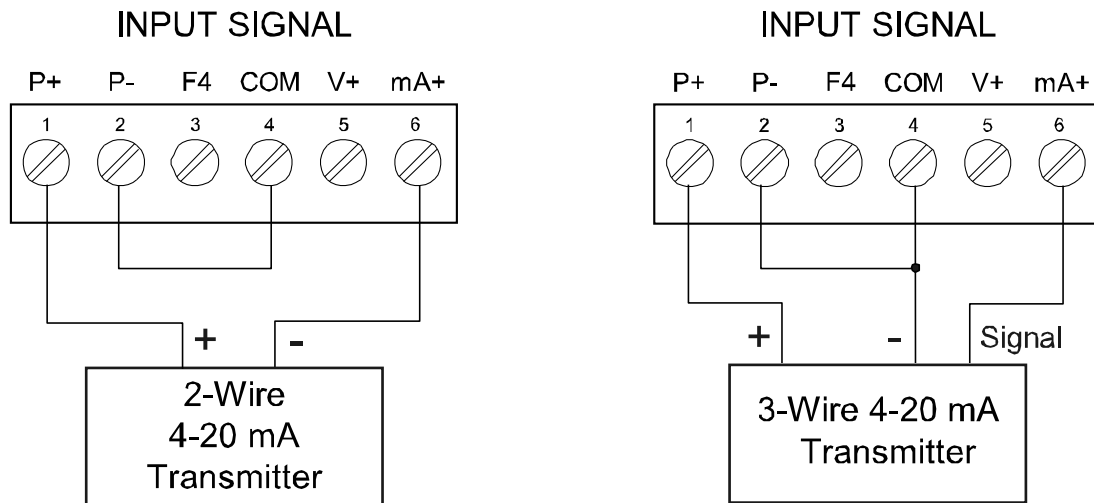

Figure 9. Transmitters Powered by Internal Supply

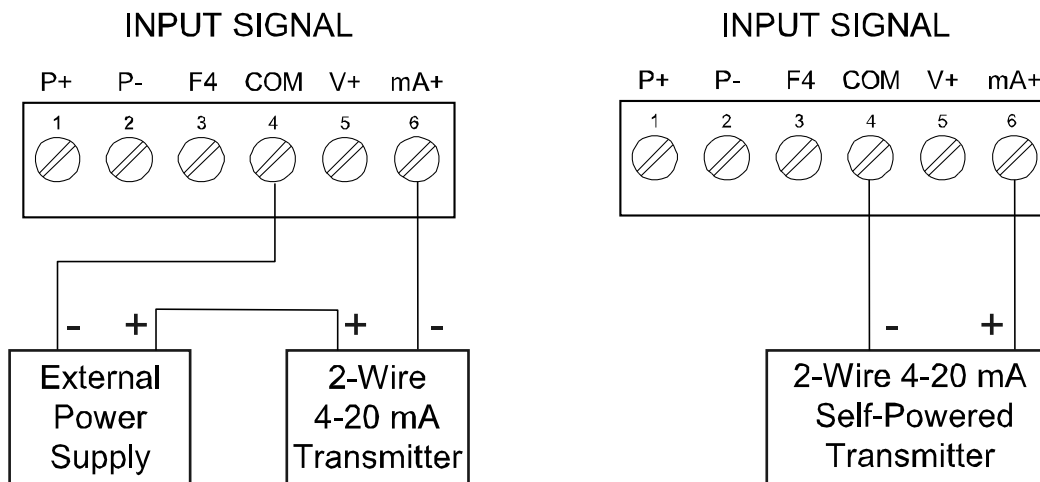
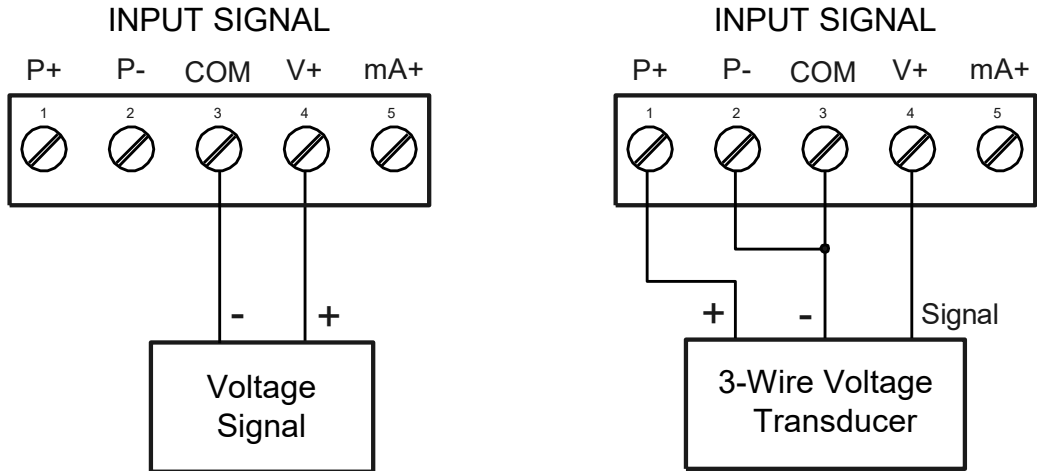

Figure 10. Transmitter Powered by Ext. Supply or Self-Powered

The current input is protected against current overload by a resettable fuse. The display may or may not show a fault condition depending on the nature of the overload.

The fuse limits the current to a safe level when it detects a fault condition, and automatically resets itself when the fault condition is removed.



**Figure 11. Voltage Input Connections**

The meter is capable of accepting any voltage from -10 VDC to +10 VDC.

### Modbus RTU Serial Communications

Serial communications connection can be made to the onboard RS485 terminal block or USB connector shown in Figure 7. If RS232 is required, an RS485 to RS232 adapter (PDA7485) may be used. See Ordering Information on page 5 for additional information.

### Relay Connections

Relay connections are made to two six-terminal connectors labeled RELAY1 – RELAY4 on Figure 7. Each relay's C terminal is common only to the normally open (NO) and normally closed (NC) contacts of the corresponding relay. The relays' C terminals should not be confused with the COM (common) terminal of the INPUT SIGNAL connector.

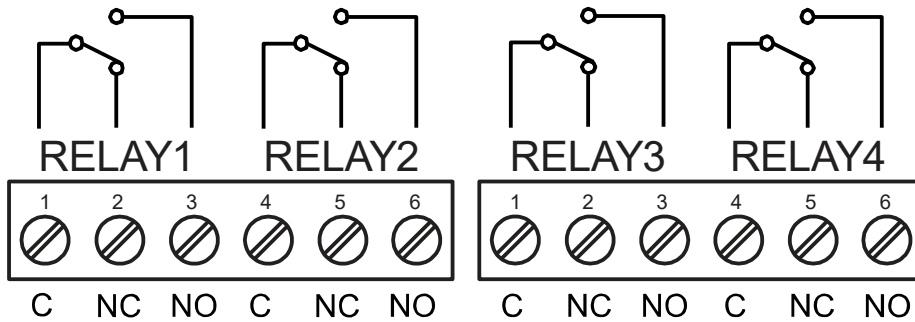

**Figure 12. Relay Connections**

## Switching Inductive Loads

The use of suppressors (snubbers) is strongly recommended when switching inductive loads to prevent disrupting the microprocessor's operation. The suppressors also prolong the life of the relay contacts. Suppression can be obtained with resistor-capacitor (RC) networks assembled by the user or purchased as complete assemblies. Refer to the following circuits for RC network assembly and installation:

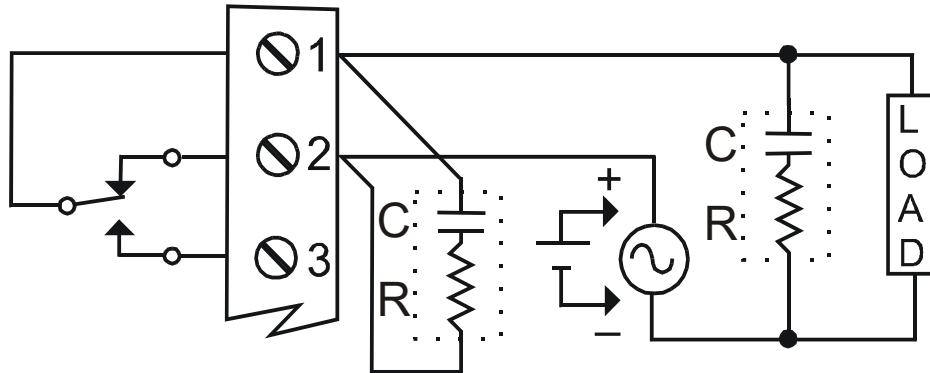

**Figure 13. AC and DC Loads Protection**

Choose R and C as follows:

R: 0.5 to 1  $\Omega$  for each volt across the contacts

C: 0.5 to 1  $\mu\text{F}$  for each amp through closed contacts

*Notes:*

1. Use capacitors rated for 250 VAC.
2. RC networks may affect load release time of solenoid loads. Check to confirm proper operation.
3. Install the RC network at the meter's relay screw terminals. An RC network may also be installed across the load. Experiment for best results.

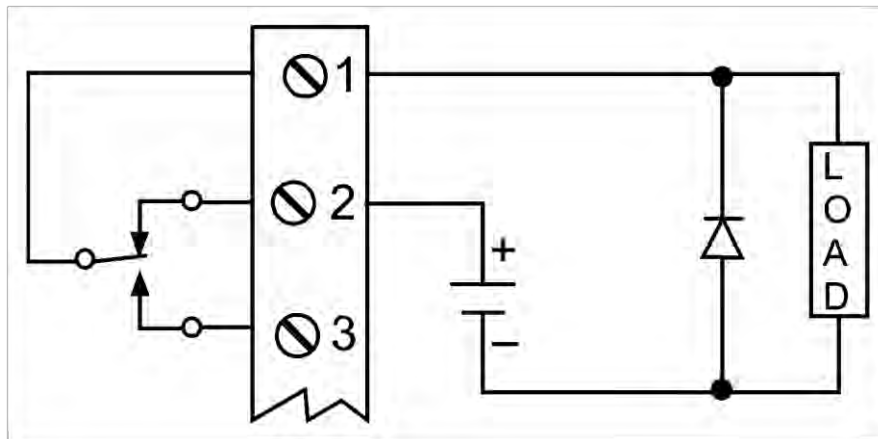

**Figure 14. Low Voltage DC Loads Protection**

Use a diode with a reverse breakdown voltage two to three times the circuit voltage and forward current at least as large as the load current.

### *RC Networks Available from Precision Digital*

RC networks are available from Precision Digital and should be applied to each relay contact switching an inductive load. Part number: PDX6901.

*Note: Relays are de-rated to 1/14th HP (50 watts) with an inductive load.*

## RS485 Output Connections

An RS-485 connector is provided for the use of advanced Modbus<sup>®</sup> serial communications. This connector converts the serial output of the meter to balanced, full or half-duplex RS-485 signals. It has a removable screw terminal connector for the RS-485 terminals which includes Transmit Data (DO) and (/DO), Receive Data (DI) and (/DI), and Signal Ground. Baud rates are adjustable and handled by the meter (see Modbus RTU Serial Communications on page 52 for more information).

The RS-485 connector has three diagnostic LEDs: a Power (PWR) LED to show when the adapter is powered properly, a Transmit Data (TX) LED to show when the adapter is sending data out from the PC side, and a Receive Data (RX) LED to show when the adapter is receiving data from the meter.

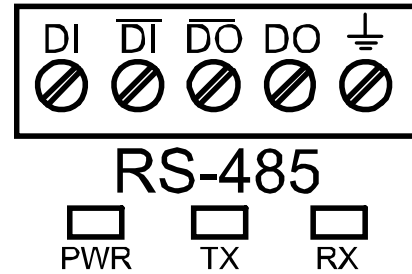

### Installation

Figure 15 shows the connection of a meter to a PC using the RS485 output connector and a PDA7485 RS-232 to RS-422/485 converter in an RS-422 network. Figure 16 shows the connection of several meters to a PC using a PDA7485 RS-232 to RS-422/485 converter in an RS-485 network.

When using more than one meter in a multi-drop mode, each meter must be provided with its own unique address. The meter address (Slave ID) may be programmed between 1 and 247. The transmit delay may be set between 0 and 199 ms. The parity can be set to even, odd, or none with 1 or 2 stop bits.

#### To change the meter address:

1. Press and hold the **Menu** button for three seconds to access *Advanced Features* menu of the meter.
2. Press **Up** arrow until Serial (*SErIAL*) menu is displayed and press **Enter**, *Addr-E5* is displayed.
3. Press **Enter** to change meter address using **Right** and **Up** arrow buttons. Press **Enter** to accept.
4. Press **Menu** button to exit and return to Run Mode.

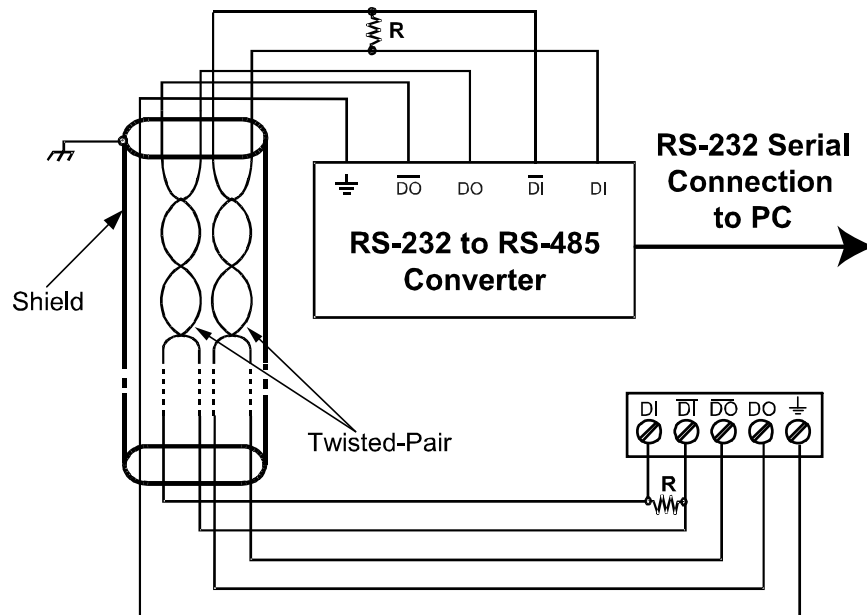
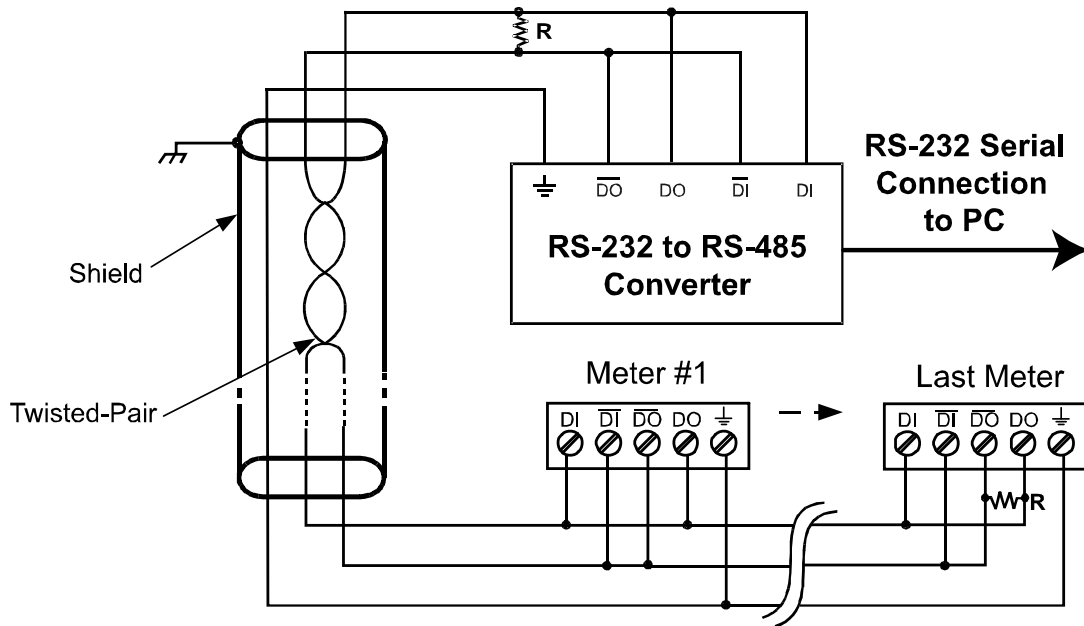

Figure 15. RS-422 or RS-485 Wiring

#### Notes:

1. Termination resistors are optional and values depend on the cable length and characteristic impedance. Consult the cable manufacturer for recommendations.
2. Refer to RS-232 to RS-422/485 Converter documentation for further details.
3. Use shielded cable, twisted-pairs plus ground. Connect ground shield only at one location.



**Figure 16. RS-485 Two-Wire Multi-Drop Wiring**

**Notes:**

1. Termination resistors are optional and values depend on the cable length and characteristic impedance. Consult the cable manufacturer for recommendations.
2. Refer to RS-232 to RS-485 Converter documentation for further details.
3. Use shielded cable, twisted-pair plus ground. Connect ground shield only at one location.

**Connections**

Figure 17 details the wiring connections from the RS-485 connector to an RS-422/485 serial converter (such as the PDA7485 or PDA8485) for a four-wire network.

| RS485 Connector to RS-422/485 Serial Converter Connections |                        |
|--|------------------------|
| RS-422/485 Serial Converter                                | PDA1485 RS-485 Adapter |
| ⏏  | ⏏                      |
| $\overline{DO}$  | DI                     |
| DO   | DI                     |
| $\overline{DI}$  | $\overline{DO}$        |
| DI   | DO                     |

**Figure 17. Connections for RS485 Connector to Serial Converter**

**Three Wire Connection**

In order to wire the 5 pins for use as a 3-wire half-duplex RS-485 connection, it is necessary to create a jumper connection between DI – DO and  $\overline{DI}$  –  $\overline{DO}$  as shown below.

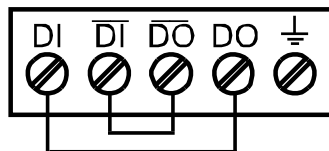

**Figure 18. Three-Wire RS485 Connection**

## Digital I/O Connections

Digital inputs and outputs are provided in order to expand the functionality of the meter. Digital inputs are made via a push button or switch connection to the appropriate digital input connector block and the +5 VDC block. Digital output connections are made by wiring from the appropriate digital output block to the grounding terminal block.

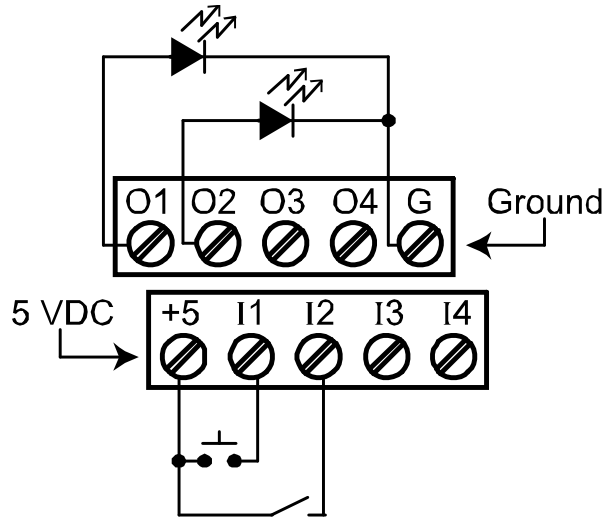

**Figure 19. Digital Input and Output Connections**

## F4 Digital Input Connections

Digital input F4 is also available on the meter. This digital input is connected with a normally open contact across F4 and COM, or with an active low signal applied to F4.

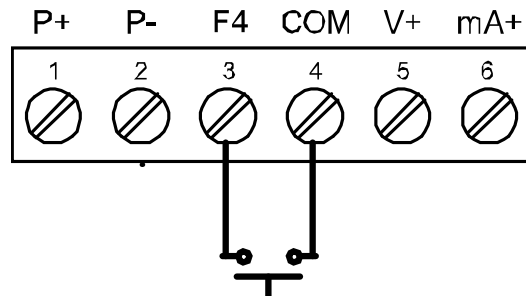

**Figure 20. F4 Digital Input Connections**



### 4-20 mA Output Connections

Connections for the 4-20 mA transmitter output are made to the connector terminals labeled MA OUT. The 4-20 mA output may be powered internally or from an external power supply.

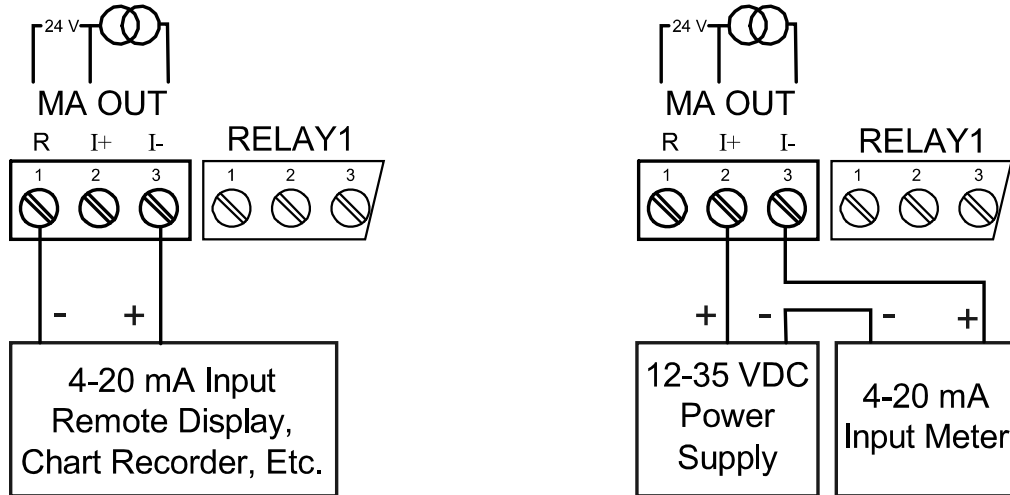

Figure 21. 4-20 mA Output Connections

### Analog Output Transmitter Power Supply

The internal 24 VDC power supply powering the analog output may be used to power other devices, if the analog output is not used. The I+ terminal is the +24 V and the R terminal is the return.

### Interlock Relay Feature

As the name implies, the interlock relay feature reassigns one, or more, alarm/control relays for use as interlock relay(s). Interlock contact(s) are wired to digital input(s) and trigger the interlock relay. This feature is enabled by configuring the relay, and relative digital input(s) (see page 45). In one example, dry interlock contacts are connected in series to one digital input which will be used to force on (energize) the assigned interlock power relay when all interlock contacts are closed (safe). The interlock relay front panel LED flashes when locked out. The interlock relay would be wired in-series with the load (N/O contact). See below.

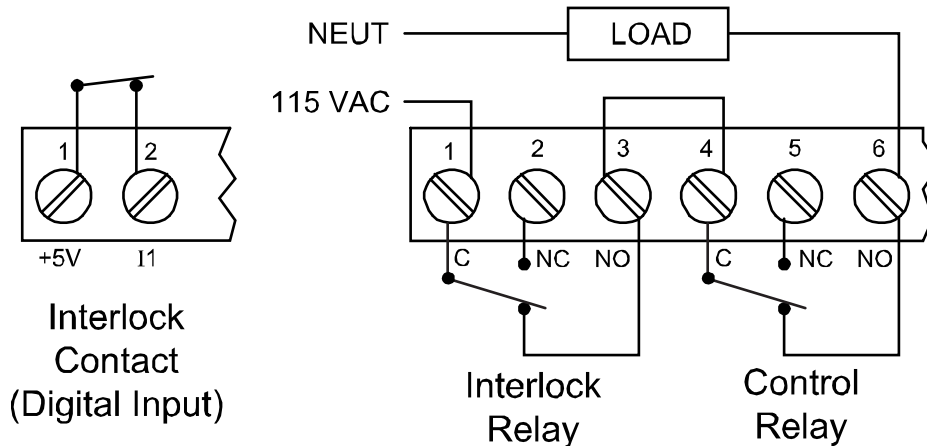

Figure 22. Interlock Connections

## Basic Operation and Programming

*The meter is factory calibrated prior to shipment to read in milliamps and volts depending on the input selection. The calibration equipment is certified to NIST standards.*

### Overview

There are no jumpers to set for the meter input selection.

Setup and programming are done through the programming buttons located under the front door panel.

After power and input signal connections have been completed and verified, apply power to the meter.



### Programming Buttons and Status LED Indicators

The meter can be programmed using the buttons located behind the front door panel. Use the *Menu* button to enter or exit *Programming Mode*, the *Up Arrow* button to cycle through menu options, and the *Enter* button to select the menu item or option you want. The *Right Arrow* button is used during numeric and decimal point programming.

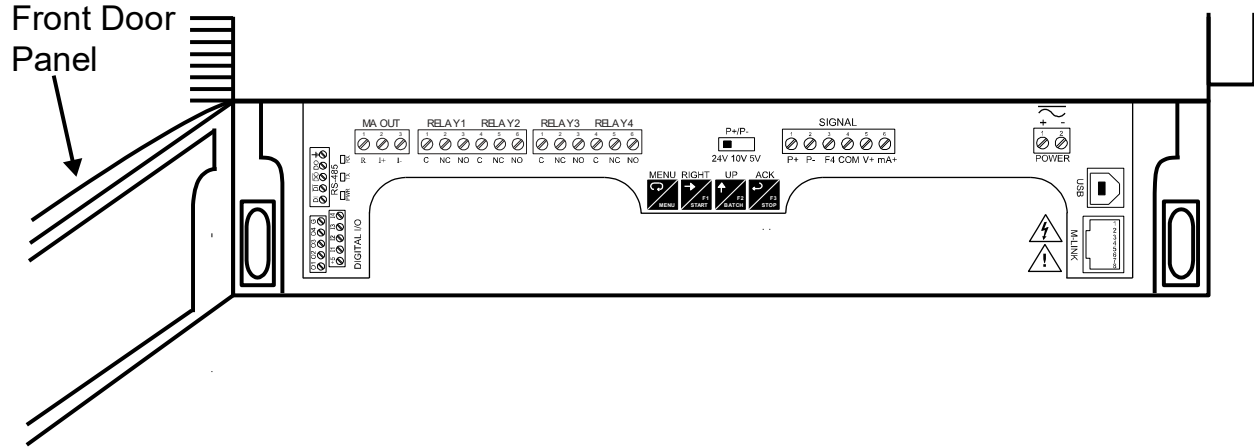

| Button Symbol                               | Description                           |
|---|---------------------------------------|
|   | <b>Menu</b>                           |
|   | <b>START</b><br>Right arrow/F1        |
|   | <b>BATCH</b><br>Up arrow/F2           |
|   | <b>STOP</b><br>Acknowledge (Enter)/F3 |
| <i>Note:</i><br>F4 – F8 are digital inputs. |                                       |

| LED | Status  |
|-----|---|
| 1-4 | Alarm 1-4 indicator   |
| R   | Rate Indicator  |
| T   | Batch total indicator   |
| G T | Grand total indicator   |
| ▲   | Total overflow indicator  |
| M   | <i>Flashing: Manual control of flashing relays. M flashing alone indicates manual analog output. Indicators flash every 10 seconds.</i> |

- Press the Menu button to enter or exit the Programming Mode at any time.
- Press the Right arrow button to move to the next digit during digit or decimal point programming.
- Press or hold the Up arrow button to scroll through the menus, decimal point, or to increment the value of a digit.
- Press the Enter button to access a menu or to accept a setting.
- Press and hold the Menu button for three seconds to access the advanced features of the meter.

## MeterView® Pro Software

The meter can also be programmed using the PC-based MeterView Pro software included with the meter. This software can be installed on any Microsoft® Windows® (2000/XP/Vista/7/8/10) computer by connecting the meter's onboard USB. The meter is powered by the USB connection, so there is no need to wire anything prior to programming the meter, though USB is intended only for meter configuration.

### MeterView Pro Installation

1. Connect one end of the provided USB cable to the meter and the other end to the computer. The computer will automatically install the driver software it needs to talk to the meter.  
**Only one meter may be connected at a time. Attaching multiple meters will cause a conflict with the meter software. Disconnect other meters before performing these steps.**

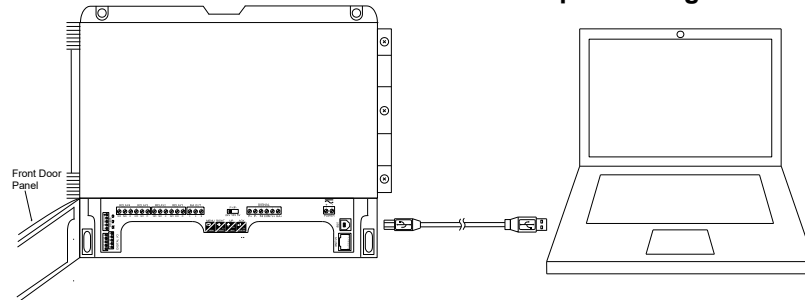

2. Once the driver is installed, an AutoPlay dialog should appear for the drive "MAINSTAL." Click "Open folder to view files." If the computer does not display an AutoPlay dialog for the drive "MAINSTAL," you should open My Computer and double-click on the drive labeled "MAINSTAL."
3. Double-click on the file named "MAStart." The program will open a few windows and install two programs on your computer. Simply follow the onscreen instructions until you see one of the dialogs below. If you receive a "User Account Control" warning, click "Yes."
4. If there is an update available, click the "Update" button to install the new version. Otherwise, click "Configure" to begin programming your meter.

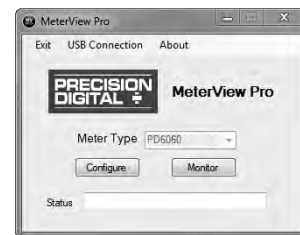
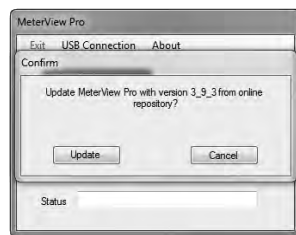

**Note:** If you decide to update your MeterView Pro software, once the installation has completed, you will be asked if you want to update the setup files located on the meter itself. This way, you will always have the most current version on the meter for future installs.



**Warning**

**Do not unplug the meter while the new installation files are being written to it. The meter will display  $\mu r t E$  during the process and you will receive an onscreen notification once the process is complete.**

Data logging for one meter at a time is available with MeterView Pro software. More advanced data acquisition may be accomplished by using any Modbus RTU compliant software. Additional information regarding configuration and monitoring of the meter using MeterView Pro software is available online. Go to [www.predig.com/meterview-pro](http://www.predig.com/meterview-pro).

## Controller Operation

The PD2-6210 controller is capable of accepting current (0-20 mA, 4-20 mA) and voltage signals (0-5 V, 1-5 V, 0-10 V,  $\pm 10$  V). These signals are scaled to represent rate in engineering units from -99999 to 999999.

The default configuration displays batch total on the upper display, and a selection of rate, grand total, batch count, and preset on the lower display.

When in pause or stop mode, the display will alternate the numeric value with the run status in the upper display and the display label for the lower display.

The controller has up to 4 relays on board which are used to either control the batch process in single or multi-stage batch control, or as alarms that will be active when the batch process is running. A 4-20 mA output option is also available for retransmitting the process variable analog signal.

## Default Batch Control Operation

The following describes the operation of the three operating buttons as programmed with default settings.

### **START Button**

Press the START button to begin a new batch process.

### **BATCH Button**

Press the Batch button to access the Preset (batch amount) menu. Program the batch with the arrow keys, and confirm with the Enter key.

### **STOP Button**

Press the STOP key once during a batch to pause. Press the STOP key while paused to stop and cancel the batch. Press the STOP key while in stop/ready mode cycle lower display values of rate (or other lower display programmed parameter), grand total, batch count, and preset.



#### ***Only STOP Button Enabled if a Batch is Running***

*During a batch process, only the pause/stop functions of the STOP button will function. No other buttons will be functional.*

## Batch Control Operation Example

The following example shows how two stage batch control functions with a PD2-6210 controller. This setup will establish a 55 gallon preset for the batch, with a main valve (high flow) that will close at 50 gallons, and a trickle valve (low or restricted flow) that will close at 55 gallons. After the batch, the preset will be changed to 100 gallons.

### Two-Stage Batch Control Setup Using Relays 1 & 2

The following table shows the parameters as they appear within the *SEtUP* menu entry *rELAY*.

| Parameter           | Setting        | Function   |
|---------------------|----------------|--|
| <i>rELAY</i>        | <i>R55 iOn</i> | Press Enter to enter the relay assignment parameters.  |
| <i>R5 iOn 1</i>     | <i>totRL</i>   | Assign relay 1 to batch total control.   |
| <i>R5 iOn 2</i>     | <i>totRL</i>   | Assign relay 2 to batch total control.   |
| <i>PrEcLS totRL</i> |                | Press Enter to access preclose selection for multi-stage control.  |
| <i>PrEcLS</i>       | <i>YES</i>     | Yes to enable a preclose value for relay 2.  |
| <i>YES</i>          | <i>00005.0</i> | Set the preclose value to 5 for closing the valve controlling relay 2 five gallons before reaching the preset. |
| ...                 |                | Assignment for optional relays 3-4.  |
| <i>rLY 1 rELAY</i>  |                | Select relay 1 setup.  |
| <i>Act 1 rLY 1</i>  |                | Configure activation of relay 1.   |
| <i>Act 1</i>        | <i>Auto</i>    | Always set to Auto for batch control function.   |
| <i>rLY 1</i>        | <i>PrESEt</i>  | Set the preset value for batch control.  |
| <i>PrESEt</i>       | <i>00055.0</i> | Set 55 gallons as the preset.  |
| ...                 |                | Setup for optional relays 3-4.   |

The operation of relay 2 has already been assigned for multi-stage control preclose, and will not appear as a selection in the *rELAY* menu.

If only one stage batch control was desired, with one relay for control, then one would set the assignment of relay 2, *R55 iOn 2*, to off, rate, or grand total.

The following pages show an illustration of how the above settings control the batch operation. The display assignment is the default.

### Batch Control Operation

1. A new container is prepared for the batch. Both valves are closed. Note that the upper display may show the batch total from the last batch.
2. The START button is pressed. Both valves open. The barrel begins to fill as the total being dispensed is displayed in the big window. The lower window shows the rate and units, alternating.
3. When the batch total reaches 50 gallons, the preset (55) minus the preclose amount (5) for relay 2, relay 2 deactivates to close the main valve. The barrel fills more slowly as a result, improving accuracy.
4. When the batch total equals the preset, relay 1 deactivates, closing valve 1. Filling stops.
5. The BATCH button is pressed, and a new preset is entered, 100 gallons, and the enter/STOP button is pressed to confirm it.
6. The new batch begins when the START button is pressed, so both relays activate and both valves open.

### Additional Features

At any time during the batch, the STOP button may be pressed to pause the batch. When paused, the START button will continue the batch, and pressing the STOP button again will cancel the batch.

When in STOP mode, the STOP button may be pressed to cycle through alternative parameters to be displayed on the lower display, including the grand total, batch count, and preset.

The grand total and batch count may be reset in the *rESEt* menu by pressing the MENU button and entering the reset menu. It may also be reset with digital inputs.



## MANUAL MULTI-STAGE BATCH CONTROL OPERATION

### System Setup

- Both valves are closed with an empty barrel in place. The batched total is displayed in the upper display, the preset is selected for the lower display.

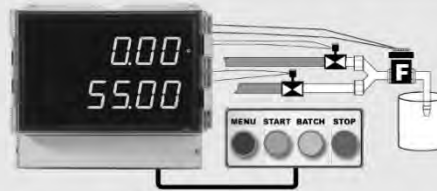

### Batch Start

- The START button is pressed, with both valves open. The barrel begins to fill.

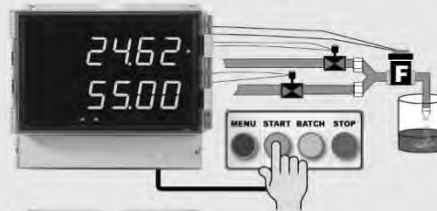

### Preclose Valve

- When the batch total reaches a value of 50.00 (Preset[55.00] - Preclose[5.00]) the full-flow valve closes. The fill rate of the tank slows as a result.



### Completed Batch

- When the batch total equals the preset amount, the restricted-flow valve closes. The barrel is now full. If some overrun occurs, the next batch will adjust for this offset amount to maintain accuracy.

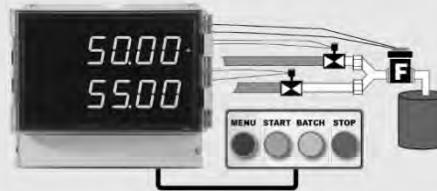

### Change Preset

- After placing a new, empty barrel, a new preset fill amount may be selected with the BATCH key, while the process is stopped.

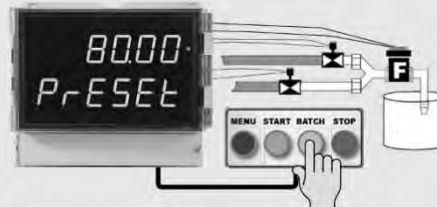

### Begin New Batch

- Press the START key and a new batch will begin. With both valves open, the process continues.



### Pause/Stop

- At any time, the STOP button may be pressed, once to Pause the process, or twice to cancel the batch, which stops the process.

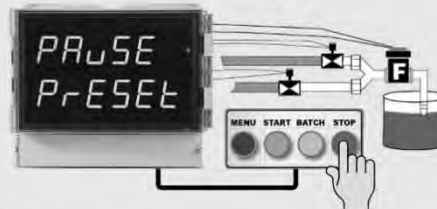

### Note:

The meters illustrated here use external push buttons connected to the onboard digital inputs. This is the recommended configuration for batch control operations.

### VALVE KEY LEGEND

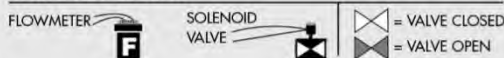

## Display Functions & Messages

The meter displays various functions and messages during setup, programming, and operation. The following table shows the main menu functions and messages in the order they appear in the menu.

| Display     | Parameter                     | Action/Setting Description  |
|-------------|-------------------------------|---|
| SEtUP       | Setup                         | Enter <i>Setup</i> menu   |
| inPut       | Input                         | Enter <i>Input</i> selection menu   |
| m A         | 4-20 mA                       | Set meter for 4-20 mA input   |
| VolT        | 0-10 VDC                      | Set meter for $\pm 10$ VDC input  |
| toTAL       | Total                         | Enable or disable totalizer features  |
| un itS      | Units                         | Select the display units/tags   |
| rAtE        | Rate                          | Select the display units for rate   |
| toTAL       | Total                         | Select the display units for total  |
| Grand toTAL | Grand Total                   | Select the display units for grand total  |
| dEc Pt      | Decimal point                 | Set decimal point   |
| PrOG        | Program                       | Enter the <i>Program</i> menu   |
| inCAL       | Input Calibration             | Enter the <i>Input Calibration</i> menu   |
| SCALE       | Scale                         | Enter the <i>Scale</i> menu   |
| CAL         | Calibrate                     | Enter the <i>Calibration</i> menu   |
| inP 1       | Input 1                       | Calibrate input 1 signal or program input 1 value                               |
| d IS 1      | Display 1                     | Program display 1 value   |
| inP 2       | Input 2                       | Calibrate input 2 signal or program input 2 value (up to 32 points)             |
| d IS 2      | Display 2                     | Program display 2 value (up to 32 points)                                       |
| Error       | Error                         | Error, calibration not successful, check signal or programmed value             |
| t tB        | Total time base               | Program total time base   |
| t CF        | Total conversion factor       | Program total conversion factor   |
| m odE       | Batch mode                    | Automatic or manual batch control   |
| t dLY       | Time delay                    | Set time delay for automatic batch restart                                      |
| Gr t tB     | Grand total time base         | Program grand total time base   |
| Gr t CF     | Grand total conversion factor | Program grand total conversion factor   |
| Gr t rSt    | Grand total reset             | Program grand total rest mode: auto or manual                                   |
| Auto        | Automatic                     | Press Enter to set automatic total reset  |
| t dLY       | Time delay                    | Program time delay for total auto reset   |
| m An        | Manual                        | Press Enter to reset total manually   |
| dSPLY       | Display                       | Enter the <i>Display</i> menu   |
| L inE 1     | Display Line 1                | Press Enter to assign the display line 1 parameter (default: PV)                |
| L inE 2     | Display Line 2                | Press Enter to assign the display line 2 parameter (default: engineering units) |
| d- In tY    | Display intensity             | Set display intensity level from 1 to 8   |
| rELAY       | Relay                         | Enter the <i>Relay</i> menu   |
| ASS gn      | Assignment                    | Assign relays to rate, total, or grand total                                    |
| AS gn 1     | Assign 1                      | Relay 1 assignment  |
| toTAL       | Total                         | Assign relay to total   |

| Display                       | Parameter                     | Action/Setting Description  |
|-------------------------------|-------------------------------|---|
| Grand total                   | Grand total                   | Assign relay to grand total   |
| Modbus                        | Modbus                        | Select to display Modbus input or to assign Modbus input as the analog output source      |
| Rate                          | Rate                          | Assign relay to rate  |
| Batch total relay preclose    | Batch total relay preclose    | For relays beyond the first assigned to total, a preclose amount may be entered.          |
| Relay 1                       | Relay 1                       | Relay 1 setup   |
| Action 1                      | Action 1                      | Set relay 1 action  |
| Automatic                     | Automatic                     | Set relay for automatic reset   |
| Auto-manual <sup>3</sup>      | Auto-manual <sup>3</sup>      | Set relay for automatic & manual reset any time   |
| Latching <sup>1</sup>         | Latching <sup>1</sup>         | Set relay for latching operation  |
| Latching-cleared <sup>1</sup> | Latching-cleared <sup>1</sup> | Set relay for latching operation with manual reset only after alarm condition has cleared |
| Alternate <sup>4</sup>        | Alternate <sup>4</sup>        | Set relay for pump alternation control  |
| Sampling                      | Sampling                      | Set relay for sampling operation  |
| Off                           | Off                           | Disable relay and front panel status LED (Select Off to enable Interlock feature)         |
| Preset                        | Preset                        | Set batch preset  |
| Set 1                         | Set 1                         | Program set point 1   |
| Reset 1                       | Reset 1                       | Program reset point 1   |
| Relay 2                       | Relay 2                       | Relays 2-4 setup  |
| Fail-safe                     | Fail-safe                     | Enter <i>Fail-safe</i> menu   |
| Fail-safe 1                   | Fail-safe 1                   | Set relay 1 fail-safe operation   |
| On                            | On                            | Enable fail-safe operation  |
| Off                           | Off                           | Disable fail-safe operation   |
| Fail-safe 2                   | Fail-safe 2                   | Set relays 2-8 fail-safe operation  |
| Delay                         | Delay                         | Enter relay <i>Time Delay</i> menu  |
| Delay 1                       | Delay 1                       | Enter relay 1 time delay setup  |
| On 1                          | On 1                          | Set relay 1 On time delay   |
| Off 1                         | Off 1                         | Set relay 1 Off time delay  |
| Delay 2                       | Delay 2                       | Enter relays 2-8 time delay setup   |
| Loop break                    | Loop break                    | Set relay condition if loop break detected  |
| Ignore                        | Ignore                        | Ignore loop break condition (Processed as a low signal condition)                         |
| On                            | On                            | Relay goes to alarm condition when loop break is detected                                 |
| Off                           | Off                           | Relay goes to non-alarm condition when loop break is detected                             |
| Analog output                 | Analog output                 | Enter the <i>Analog output</i> scaling menu   |
| Display 1                     | Display 1                     | Program display 1 value   |
| Output 1                      | Output 1                      | Program output 1 value (e.g. 4.000 mA)  |
| Display 2                     | Display 2                     | Program display 2 value   |
| Output 2                      | Output 2                      | Program output 2 value (e.g. 20.000 mA)   |

<sup>3</sup> During operation, only the STOP button will function, to stop/pause the batch. As a result, relay alarms cannot be manually reset.

<sup>4</sup> This setting used for level control applications. It is not appropriate if using this controller for batching applications.

|                          |                             |  |
|--------------------------|-----------------------------|--|
| <i>rESEt</i>             | <i>Reset</i>                | Press Enter to access the <i>Reset</i> menu                                |
| <i>rSt H i</i>           | <i>Reset high</i>           | Press Enter to reset max display   |
| <i>rSt Lo</i>            | <i>Reset low</i>            | Press Enter to reset min display   |
| <i>rSt HL</i>            | <i>Reset high &amp; low</i> | Press Enter to reset max & min displays                                    |
| <i>rSt t</i>             | <i>Reset total</i>          | Press Enter to reset total   |
| <i>rSt Gt</i>            | <i>Reset grand total</i>    | Press Enter to reset grand total   |
| <i>rSt bc</i>            | <i>Reset batch count</i>    | Press Enter to reset batch count   |
| <i>ContRL</i>            | <i>Control</i>              | Enter <i>Control</i> menu  |
| <i>Auto</i>              | <i>Automatic</i>            | Press Enter to set meter for automatic operation                           |
| <i>Man</i>               | <i>Manual</i>               | Press Enter to manually control relays or analog output operation          |
| <i>PASS</i>              | <i>Password</i>             | Enter the <i>Password</i> menu   |
| <i>PASS 1</i>            | <i>Password 1</i>           | Set or enter Password 1  |
| <i>PASS 2</i>            | <i>Password 2</i>           | Set or enter Password 2  |
| <i>PASS 3</i>            | <i>Password 3</i>           | Set or enter Password 3  |
| <i>totRL</i>             | <i>Total password</i>       | Set or enter password for manual reset                                     |
| <i>GtotRL</i>            | <i>Grand total password</i> | Set or enter password for manual reset                                     |
| <i>nonrSt</i>            | <i>Non-resettable</i>       | Non-resettable grand total set after entering "050873" for Gtotal password |
| <i>unLoc</i>             | <i>Unlocked</i>             | Program password to lock meter   |
| <i>Locd</i>              | <i>Locked</i>               | Enter password to unlock meter   |
| <i>999999<br/>-99999</i> | <i>Flashing</i>             | Over/under range condition   |

## Main Menu

The main menu consists of the most commonly used functions: *Setup*, *Reset*, *Control*, and *Password*.

- Press Menu button to enter Programming Mode then press the Up arrow button to scroll main menu.
- Press Menu, at any time, to exit and return to *Run Mode*. Changes made to settings prior to pressing Enter are not saved.
- Changes to the settings are saved to memory only after pressing Enter/F3.
- The display moves to the next menu every time a setting is accepted by pressing Enter/F3.

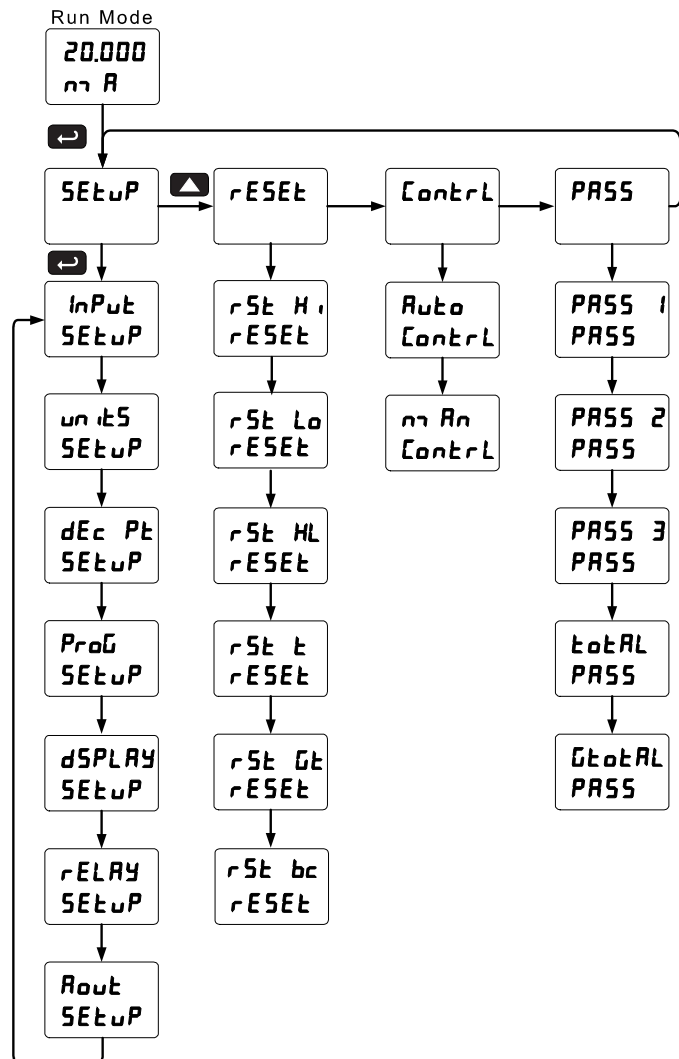

## Setting Numeric Values

The numeric values are set using the Right and Up arrow buttons. Press Right arrow to select next digit and Up arrow to increment digit value.

The digit being changed is displayed brighter than the rest.

Press and hold up arrow to auto-increment the display value.

Press the Enter button, at any time, to accept a setting or Menu button to exit without saving changes.

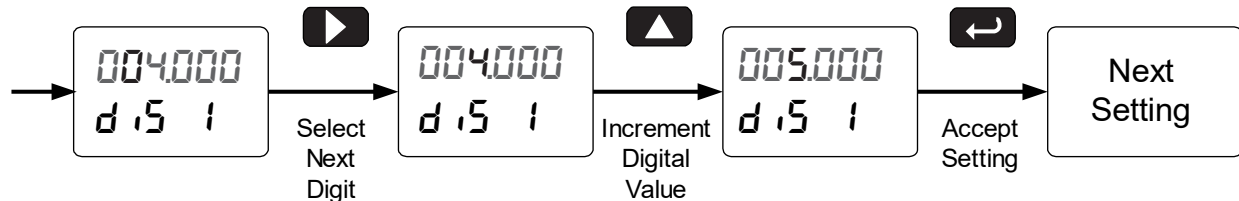

## Setting up the Batch Controller (SEtUP)

The *Setup* menu is used to select:

1. Input signal the controller will accept
2. Totalizer and batching features
3. Display units/tags
4. Decimal point position
5. Program menu for scaling or calibration
6. Display parameter and intensity
7. Relay operation
8. 4-20 mA analog output scaling

Press the Enter button to access any menu or press Up arrow button to scroll through choices. Press the Menu button to exit at any time.

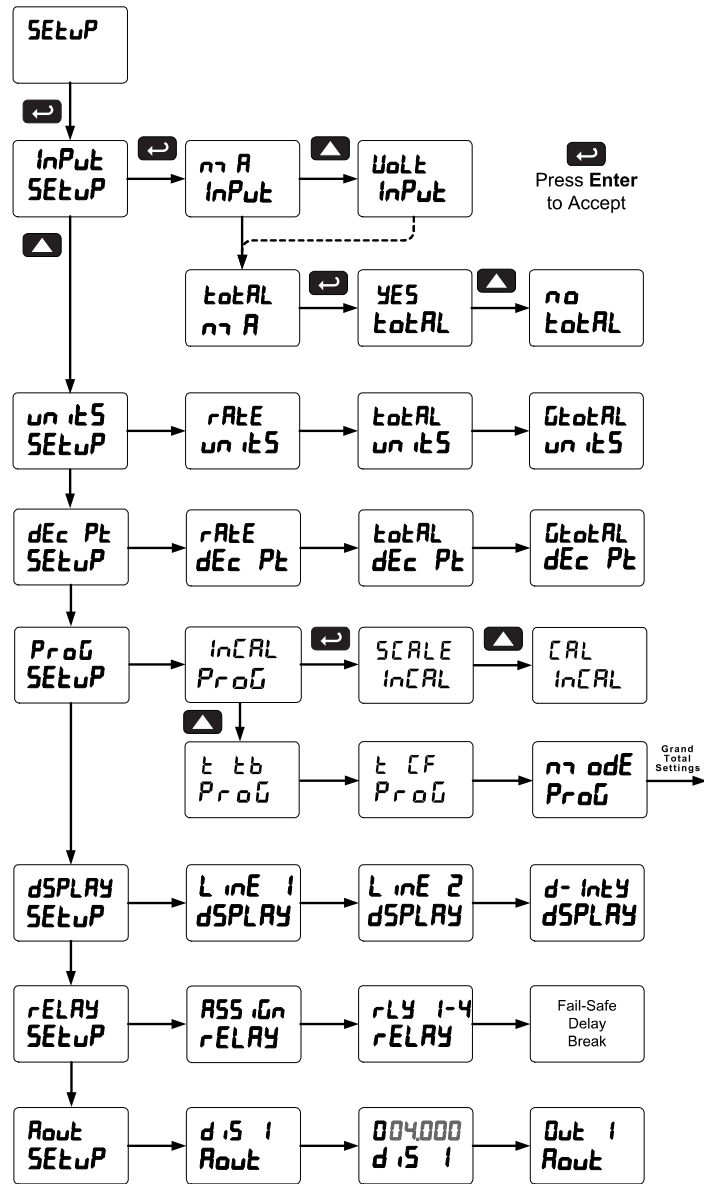

## Setting the Input Signal ( InPUt )

Enter the *Input* menu to set up the meter to display current (mA) or voltage (VOLT) inputs.

The current input is capable of accepting any signal from 0 to 20 mA. Select current input to accept 0-20 mA or 4-20 mA signals.

The voltage input is capable of accepting any signal from -10 to +10 VDC. Select voltage input to accept 0-5, 1-5, 0-10, or ±10 VDC signals.

## Setting the Totalizer and Batching Features (tOtAL)

To simply not display the total, select alternative display parameters in the display (*dSPLY*) menu.

Enable or disable the totalizer and batching features by selecting “YES” or “no” after the input type has been set up. If the totalizer features are disabled, all the totalizer and batching features and functions are hidden from the menus. Level and process meter functions are added to the menus.

If disabling the *tOtAL* parameter by selecting *no*, please refer to the PD2-6000 manual available at [www.predig.com](http://www.predig.com) for instructions on setting up the meter parameters.

*Notes:* 1. *The totalizer continues working in the background.*

2. *When selecting "no" for Total, the meter now functions as a PD2-6000 Process Meter. We strongly suggest that you download and use the PD2-6000 instruction manual from our website ([www.predig.com](http://www.predig.com)) while in this mode of operation.*

### Setting the Input Units or Custom Tags (d u n t 5)

Enter the input unit or custom tag that will be displayed if d u n t 5 is selected as the little display parameter. See the flow chart on page 38 to access the display menu to show the unit or tag on the little display. The engineering units or custom legends can be set using the following 7-segment character set:

| Display | Character | Display | Character | Display | Character | Display | Character |
|---------|-----------|---------|-----------|---------|-----------|---------|-----------|
| 0       | 0         | C       | C         | K       | K         | V       | V         |
| 1       | 1         | c       | c         | L       | L         | w       | w         |
| 2       | 2         | d       | d         | m       | m         | X       | X         |
| 3       | 3         | E       | E         | n       | n         | Y       | Y         |
| 4       | 4         | F       | F         | O       | O         | Z       | Z         |
| 5       | 5         | G       | G         | o       | o         | -       | -         |
| 6       | 6         | g       | g         | P       | P         | /       | /         |
| 7       | 7         | H       | H         | q       | q         | ]       | ]         |
| 8       | 8         | h       | h         | r       | r         | [       | [         |
| 9       | 9         | l       | l         | S       | S         | =       | =         |
| A       | A         | i       | i         | t       | t         | °       | Degree(<) |
| b       | b         | J       | J         | u       | u         |         | Space     |

Notes:

Degree symbol represented by (<) if programming with MeterView® Pro.

The letters “m” and “w” use two 7-segment LEDs each; when selected the characters to the right are shifted one position.

Press and hold up arrow to auto-scroll the characters in the display.

### Setting the Decimal Point (d E c P t)

The decimal point may be set with up to five decimal places or with no decimal point at all. The rate, total, and grand total decimal points are independent.

Pressing the Right arrow moves the decimal point one place to the right until no decimal point is displayed then it moves to the leftmost position. Pressing the Up arrow moves the decimal point one place to the left.



## Programming the Batch Controller (Prog)

It is **very important** to read the following information, before proceeding to program the meter:

- The meter is factory calibrated prior to shipment to read in milliamps and volts depending on the input selection. The calibration equipment is certified to NIST standards.
- There is **no need to recalibrate** the controller when first received from the factory.
- Use the *Scale* menu to scale process inputs (e.g. 4-20 mA). A calibrated signal source is not needed to scale the meter.
- Use the *Calibrate* menu to apply a signal from a calibrator or a flowmeter.

The *Program* menu contains the following menus:

1. Scale without a signal source
2. Calibrate with a calibrated signal source
3. Total time base & conversion factor
4. Grand total time base & conversion factor
5. Total reset mode for total & grand total

*Note: The Scale and Calibrate functions are exclusive of each other. The meter uses the last function programmed. Only one of these methods can be employed at a time. The Scale and Calibrate functions can use up to 32 points (default is 2). The number of points should be set in the Advanced Features menu under the Multi-Point Linearization (LInErr) menu selection prior to scaling and calibration of the meter, see page 53 for details.*

The process input may be calibrated or scaled to any display value within the range of the meter.

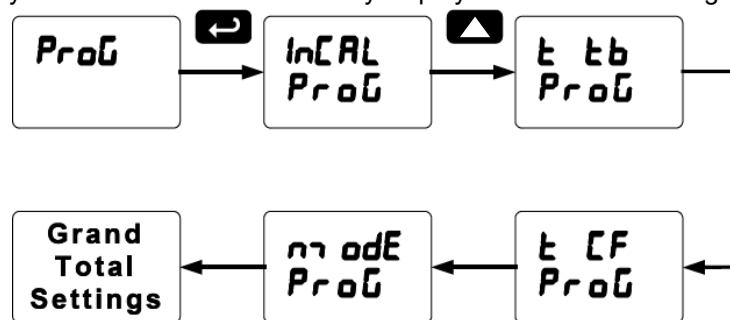

Additional parameters, not needed for most applications, are programmed in the *Advanced Features* menu; see *Advanced Features Menu*, page 50.

### *Multi-Point Calibration & Scaling*

The meter is set up at the factory for 2-point linear calibration. The number of points for multi-point calibration/scaling is set up in the *Advanced Features* menu. Up to 32 linearization points may be selected. See page 53 for details.



### Input Calibration Method (InCAL)

There are two methods of calibrating (or scaling) the display to show the correct engineering units.

- Use the *Scale* menu to enter the scaling without a signal source.
- Use the *Calibrate* menu to apply a signal from a signal source.

*Note: The Scale and Calibrate functions are exclusive of each other. The meter uses the last function programmed. Only one of these methods can be employed at a time. The Scale and Calibrate functions can use up to 32 points (default is 2). The number of points should be set in Scale and Calibrate accordingly under the Number of Points (nOPt5) menu selection prior to scaling and calibration of the meter, see page 53 for details.*

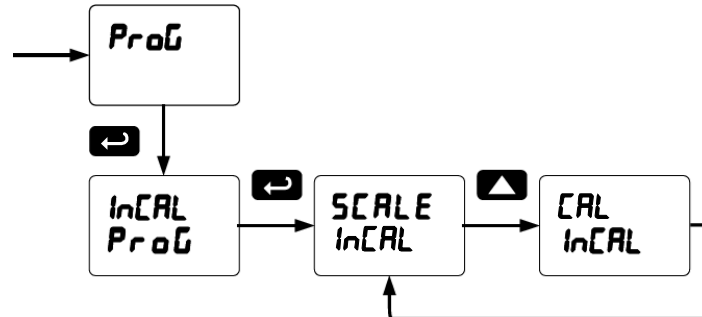

### Scaling the Meter (SCALE)

The process inputs (4-20 mA and ±10 VDC) can be scaled to display the process variable in engineering units. A signal source is not needed to scale the meter; simply program the inputs and corresponding display values.

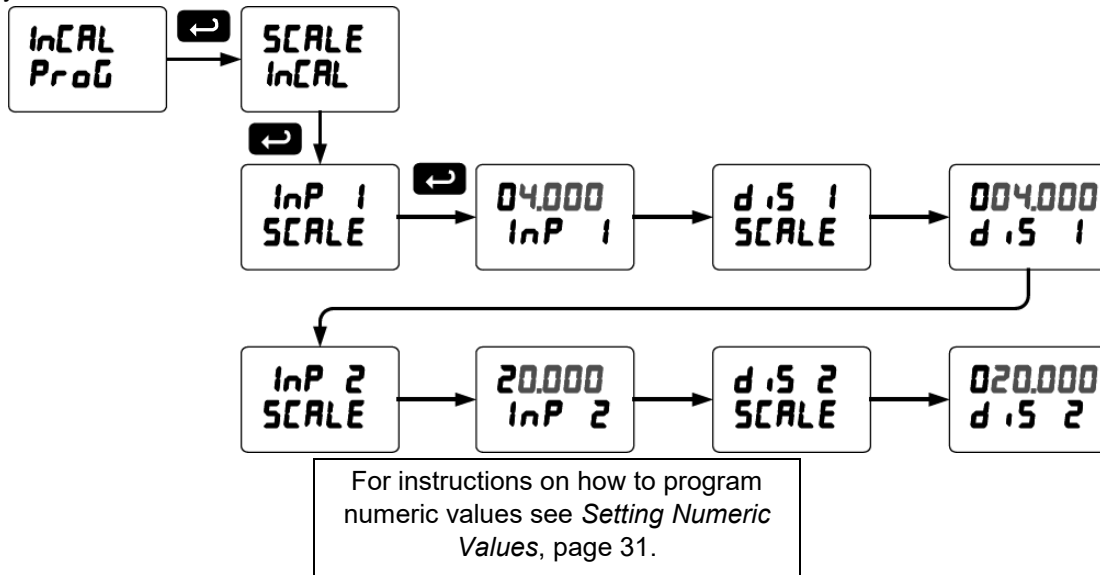

### Error Message (*Error*)

An error message indicates that the calibration or scaling process was not successful.

After the error message is displayed, the meter reverts to the input prior to the failure during calibration or scaling and to input 1 during internal calibration, allowing the appropriate input signal to be applied or programmed.

The error message might be caused by any of the following conditions:

1. Input signal is not connected to the proper terminals or it is connected backwards.
2. Wrong signal selection in *Setup* menu.
3. Minimum input span requirements not maintained.
4. Input 1 signal inadvertently applied to calibrate input 2.

### Minimum Input Span

The minimum input span is the minimum difference between input 1 and input 2 signals required to complete the calibration or scaling of the meter.

| Input Range | Input 1 & Input 2 Span |
|-------------|------------------------|
| 4-20 mA     | 0.15 mA                |
| ±10 VDC     | 0.01 VDC               |

### Calibrating the Meter with External Source (*LR*)

Note: To scale the meter without a signal source refer to *Scaling the Meter*, page 35.

The controller can be calibrated to display the process variable in engineering units by applying the appropriate input signal and following the calibration procedure.

The use of a calibrated signal source is strongly recommended to calibrate the meter.

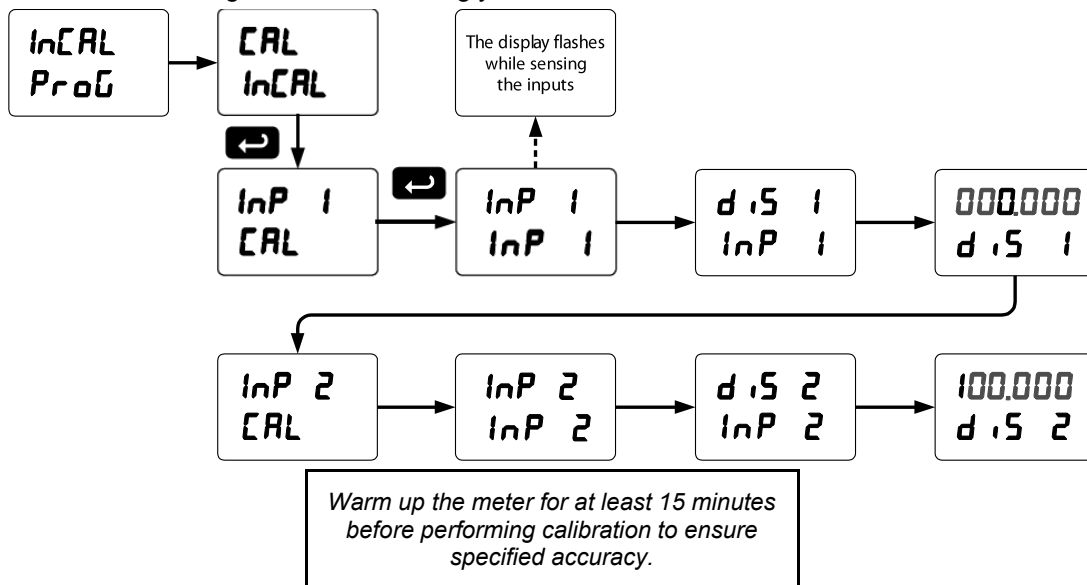

**Batch Mode, Time Base, Total Conversion Factor & Total Reset**

The time base, total conversion factor, and total reset menus are located in the *Program* menu. The total and grand total have their own independent settings. This means that one can be displaying the value in gallons while the other displays in million gallons, liters, m<sup>3</sup>, etc.

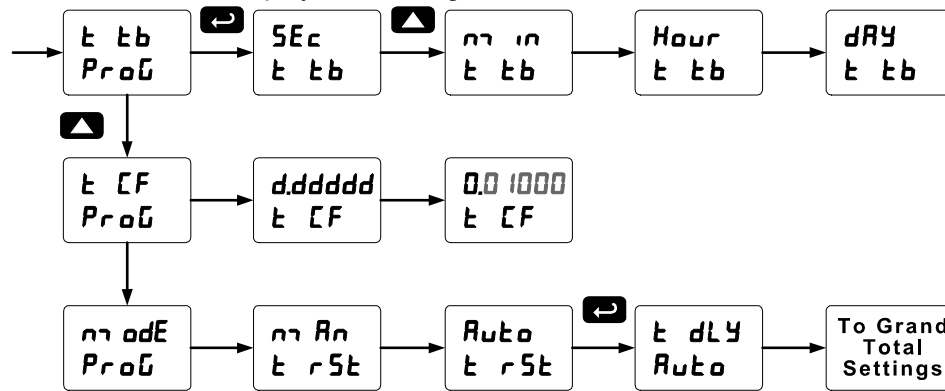

**Batch Start Mode (rSE)**

The batch controller may operate in manual or automatic mode. In manual mode, the controller operates as defined in Controller Operation as described on page 25. In automatic mode, the batch process will automatically begin after a completed batch. The time delay for the restart may be 0.1 to 999.9 seconds (dLY). Automatic batch start will only occur after a successful batch. A manually stopped batch will require a manual start to begin a new batch process.

**Time Base**

The time base is the amount of time over which the rate parameter should accrue. For example, if the rate was ten and the time base was in minutes, then the total would increase by ten every one minute.

**Total & Grand Total Conversion Factor**

The total & grand total conversion factor is the amount by which the rate is multiplied before it is added to the total or grand total. For Example, if the rate was ten per second and the total conversion factor was 100, the total would increase by 1000 every second. This is useful, for instance, if you want to show rate in gallons and total in thousands of gallons.

**Grand Total Reset**

The grand total can be programmed for manual or automatic reset. In the automatic reset mode, a programmable time delay is available to reset the total or grand total after the assigned preset is reached.

**Non-Resettable Totalizer**

The total and grand total can be password-protected to prevent unauthorized resets. The grand total can be programmed as a non-resettable total, see page 47 for details.

### Setting the Display Parameter & Intensity (dSPRAY)

The main display (LINE 1) can be programmed to display:

1. Display total
2. Display grand total
3. Toggle rate and total
4. Toggle rate and grand total
5. Display batch count
6. Relay set points
7. Toggle preset and rate
8. Toggle rate and units
9. Toggle total and units
10. Toggle grand total and units
11. Display max and min values
12. Display Modbus input
13. Display rate value

The small display (LINE 2) can be programmed to display:

1. Toggle rate and units
2. Toggle total and units
3. Toggle grand total and units
4. Display max and min values
5. Display Modbus input
6. Off (no display)
7. Display rate units
8. Display rate
9. Display total
10. Display grand total
11. Toggle rate and total
12. Toggle rate and grand total
13. Display batch count
14. Relay set points
15. Toggle preset and rate

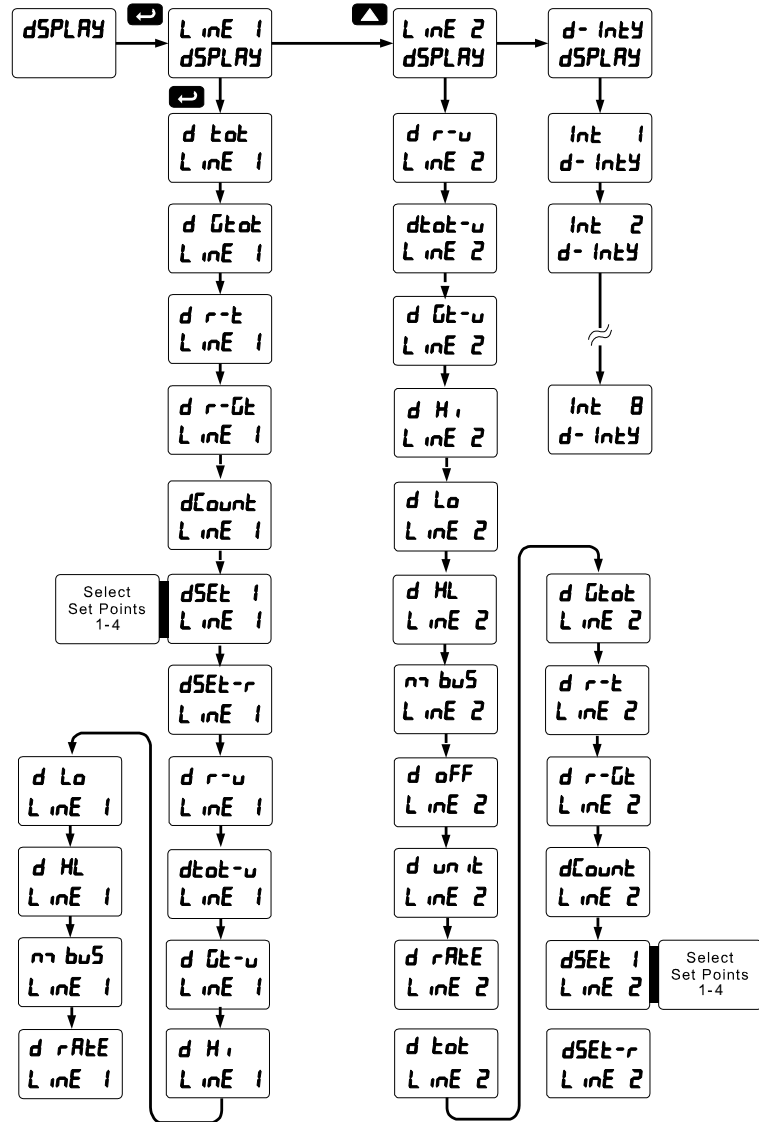

**Display Intensity:** The meter has eight display intensity levels to give the best performance under various lighting conditions. Select intensity 8 for outdoor applications. The default intensity setting is 8.

After setting up the input and display, press the Menu button to exit programming and skip the rest of the setup menu. Press the Menu button again and the Up arrow to reach the *Program* menu and complete the scaling or calibration of the meter.

## Setting the Relay Operation (rELAY)

This menu is used to set up the operation of the relays.

1. Relay assignment
  - a. Rate for low and high alarm
  - b. Total for batch control relays
  - c. Grand total for grand total alarms
  - d. Modbus input process variable
2. Relay action
  - a. Automatic reset only (non-latching)
  - b. Automatic + manual reset at any time (non-latching)
  - c. Latching (manual reset only)
  - d. Latching with Clear (manual reset only after alarm condition has cleared)
  - e. Pump alternation control (automatic reset only)
  - f. Sampling (the relay is activated for a user-specified time)
  - g. Off (relay state controlled by Interlock feature)
3. Set and reset points
4. Fail-safe operation
  - a. On (enabled)
  - b. Off (disabled)
5. Time delay
  - a. On delay (0-999.9 seconds)
  - b. Off delay (0-999.9 seconds)
6. Relay action for loss (break) of 4-20 mA input (ignore, on, off)



**Caution!** During setup, the relays do not follow the input and they will remain in the state found prior to entering the Relay menu.

Note: Fail-safe should not be used for relays assigned to batch control.



**Rate Alarms Only Active During a Batch Process**  
 The rate alarms are active only during a batch process. As a result, rate alarms should not be programmed with manual reset, as they cannot be manually reset during a batch process, the only time they are active.

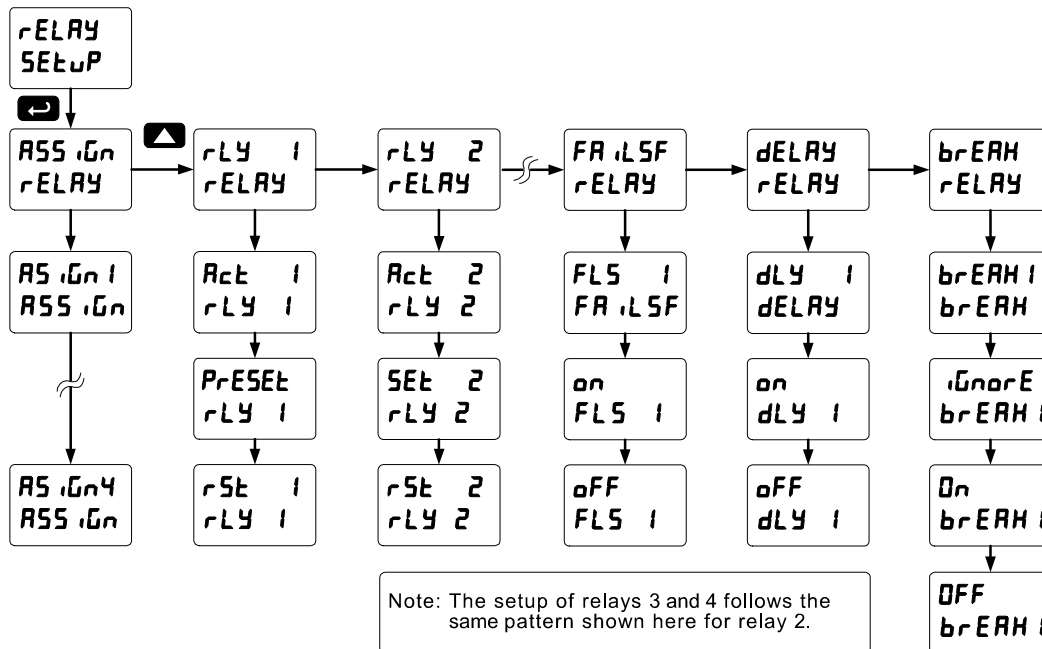

Note: The setup of relays 3 and 4 follows the same pattern shown here for relay 2.

### Relay Assignment (ASSIGN)

The relays can be assigned to any of the following parameters:

1. Rate for low or high alarm indication
2. Total for alarm indication
3. Grand total for alarm indication
4. Modbus input

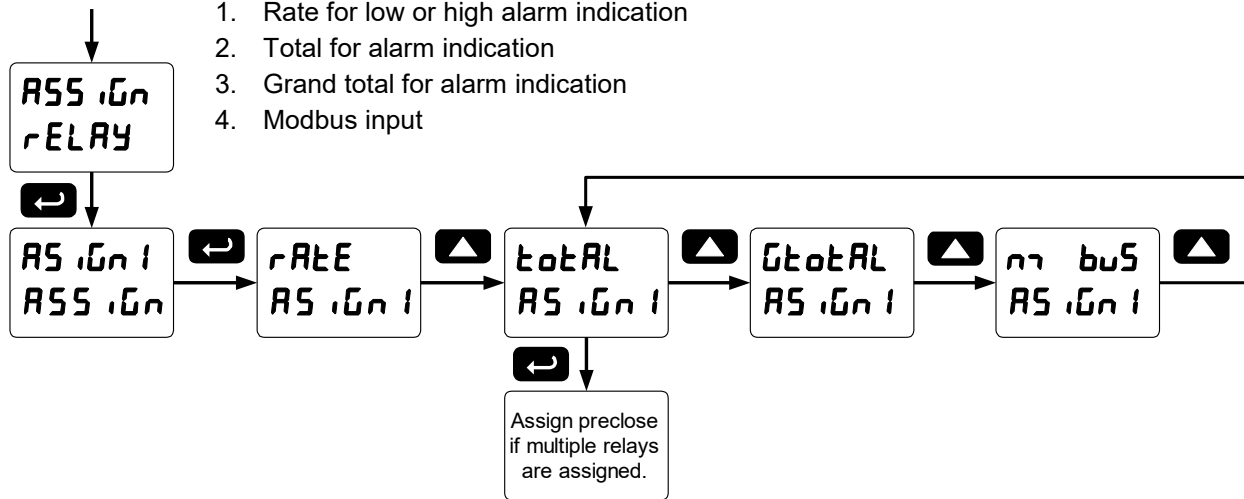

Note: Relay 1 should always be assigned to "total" for batch control applications.

### Setting the Relay Action

Operation of the relays is programmed in the *Action* menu. The relays may be set up for any of the following modes of operation:

1. Always set to Auto for Batch control operation. Also for automatic reset (non-latching) of alarms.
2. Sampling (the relay is activated for a user-specified time)
3. Off (relay state controlled by Interlock feature)

In addition, the following relay actions may be programmed. These actions are not appropriate for batch control applications, but may be used when the controller is in other applications.

4. Automatic + manual reset when not in a batch process (non-latching)
5. Latching (manual reset only, when not in a batch process)
6. Latching with Clear (manual reset only when not in a batch process after alarm condition has cleared)
7. Pump alternation control (automatic reset only, for level applications, unrelated to batch control.)

The following graphic shows relay 1 action setup; relay 2-4 are set up in a similar fashion.

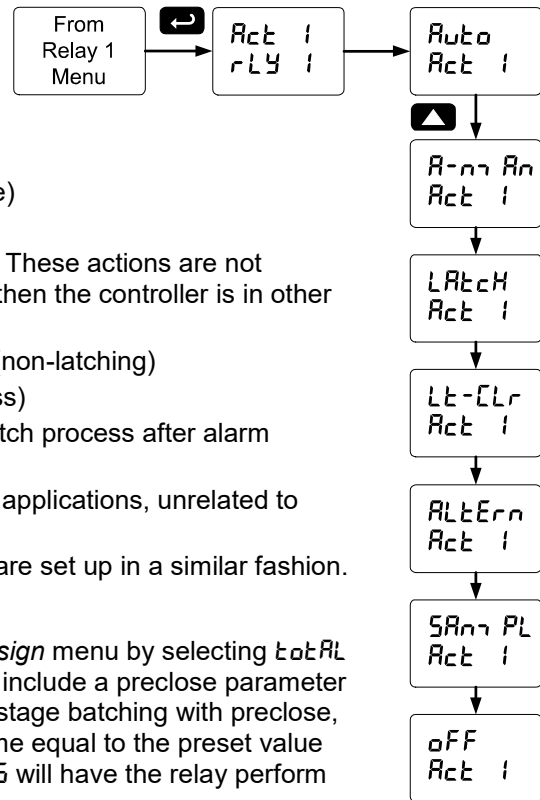

### Setting Batch Control Relays

Operation of batch control relays are programmed in the *Assign* menu by selecting *TOTAL* as the assignment. Relays set to *TOTAL* beyond the first will include a preclose parameter (*PRECLOSE*) option. Selecting *YES* for *PRECLOSE* will enable multi-stage batching with preclose, and the valve will close prior to the end of the batch at volume equal to the preset value minus the preclose amount entered. Selecting *NO* for *PRECLOSE* will have the relay perform identically to the first batch control relay set to *TOTAL*.

## Programming Set and Reset Points

High alarm indication: program set point above reset point.

Low alarm indication: program set point below reset point.

The deadband is determined by the difference between set and reset points. Minimum deadband is one display count. If the set and reset points are programmed with the same value, the relay will reset one count below the set point.

*Note: Changes are not saved until the reset point has been accepted.*

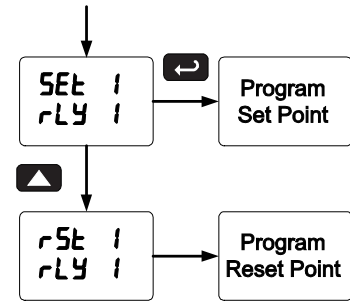

## Setting Fail-Safe Operation

In fail-safe mode of operation, the relay coil is energized when the process variable is within safe limits and the relay coil is de-energized when the alarm condition exists. The fail-safe operation is set independently for each relay. Select **on** to enable or select **oFF** to disable fail-safe operation.

Failsafe mode should not be used on batch relays assigned to total.

## Programming Time Delay

The *On* and *Off* time delays may be programmed for each relay between 0 and 999.9 seconds. The relays will transfer only after the condition has been maintained for the corresponding time delay.

The *On* time delay is associated with the set point.

The *Off* time delay is associated with the reset point.

## Relay Action for Loss of 4-20 mA Input (Loop Break)

The loop break feature is associated with the 4-20 mA input. Each relay may be programmed to go to one of the following conditions when the meter detects the loss of the input signal (i.e. < 0.005 mA):

1. Turn *On* (Go to alarm condition)
2. Turn *Off* (Go to non-alarm condition)
3. Ignore (Processed as a low signal condition)

*Note: This is not a true loop break condition; if the signal drops below 0.005 mA, it is interpreted as a "loop break" condition.*

## Relay and Alarm Operation Diagrams

The following graphs illustrate the operation of the relays, status LEDs, and ACK button.

### High Alarm Operation (Set > Reset)

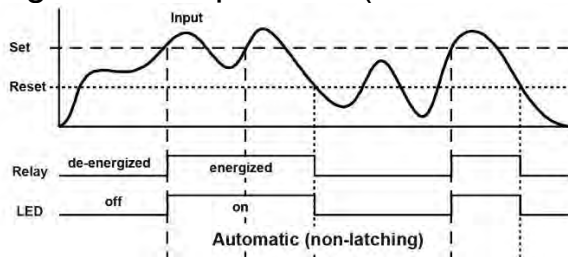

For Manual reset mode, ACK can be pressed anytime to turn "off" relay. To detect a new alarm condition, the signal must go below the set point, and then go above it.

### Low Alarm Operation (Set < Reset)

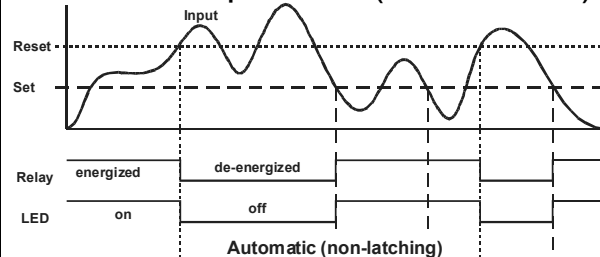

For Manual reset mode, ACK can be pressed anytime to turn "off" relay. For relay to turn back "on", signal must go above set point and then go below it.

### High Alarm with Fail-Safe Operation (Set > Reset)

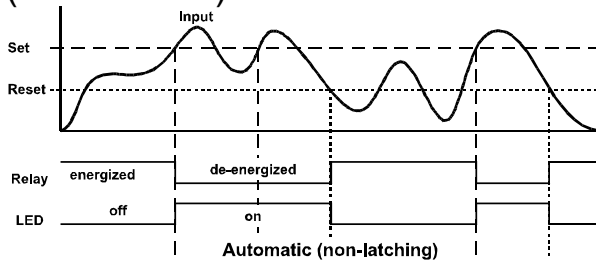

*Note: Relay coil is energized in non-alarm condition. In case of power failure, relay will go to alarm state.*

### Low Alarm with Fail-Safe Operation (Set < Reset)

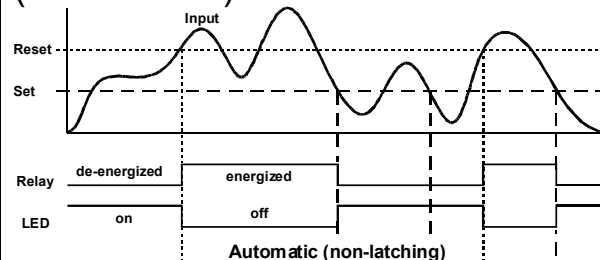

*Note: Relay coil is energized in non-alarm condition. In case of power failure, relay will go to alarm state.*

## Relay Sampling Operation

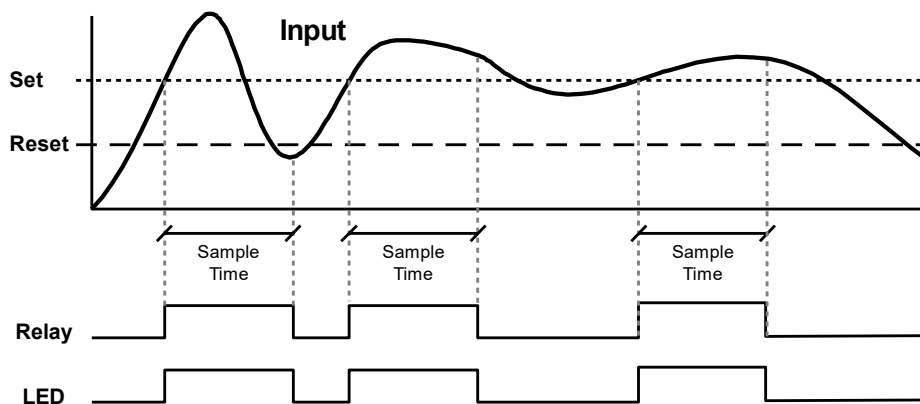

When the signal crosses the set point, the relay trips and the sample time starts. After the sample time has elapsed, the relay resets. The cycle repeats every time the set point is crossed, going up for high alarms and going down for low alarms.

The sample time can be programmed between 0.1 and 5999.9 seconds.



### Total Relay Sampling Operation

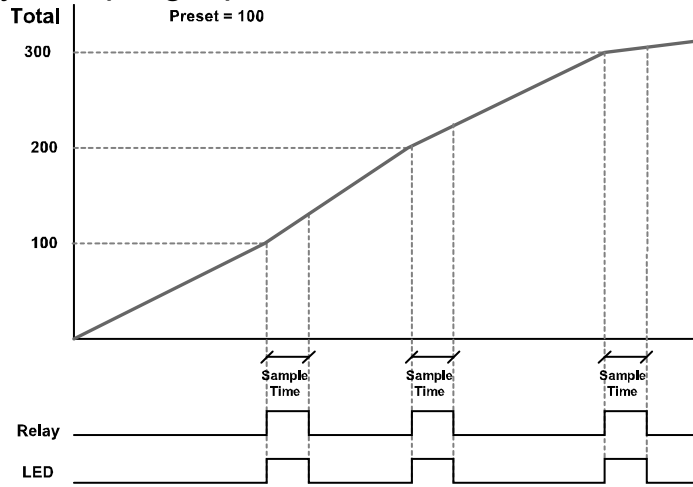

When the batch total reaches the set point, the relay trips and the sample time starts. After the sample time has elapsed, the relay resets. The cycle repeats every time the set point value is added to the batch total.

### Signal Loss or Loop Break Relay Operation

The following graph shows the loop break relay operation for a high alarm relay.

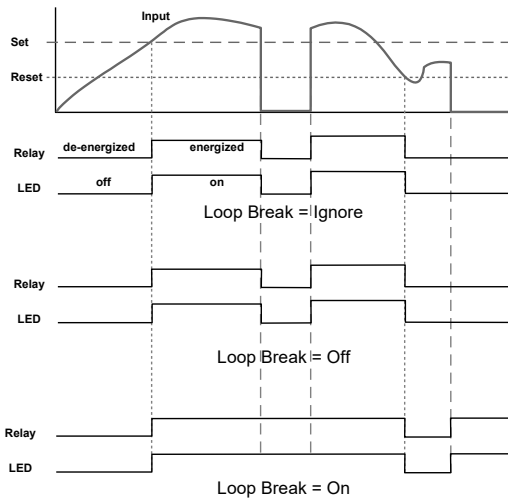

When the meter detects a break in the 4-20 mA loop, the relay will go to one of the following selected actions:

1. Turn On (Go to alarm condition)
2. Turn Off (Go to non-alarm condition)
3. Ignore (Processed as a low signal condition)

### Time Delay Operation

The following graphs show the operation of the time delay function.

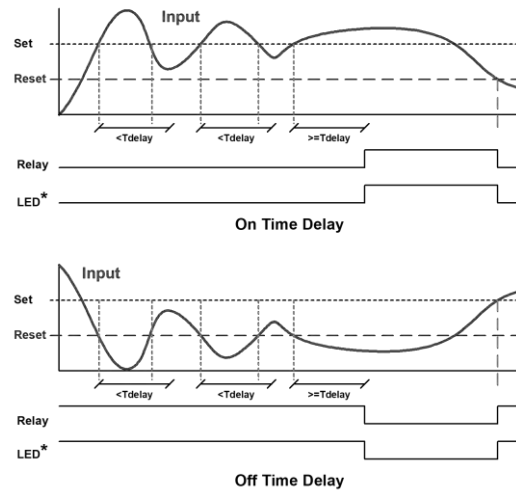

When the signal crosses the set point, the On time delay timer starts and the relay trips when the time delay has elapsed. If the signal drops below the set point (high alarm) before the time delay has elapsed, the On time delay timer resets and the relay does not change state. The same principle applies to the Off time delay.

*Note: If "Automatic or Manual (R-n, Rn)" reset mode is selected, the LED follows the reset point and not the relay state when the relay is acknowledged.*

## Relay Operation Details

### Overview

The relays of the controller can serve three roles, as batch control relays for single or multi-stage batching, as rate, or grand total alarm, or as a sampling relay based on grand total or rate alarm.

These capabilities include front panel alarm status LEDs and 2 or 4 internal relays. The relays used for batch control (total) are activated when the batching process starts, and deactivate when the batch total is reached, minus any preclose amount programmed for batch (total) relays after the first.

For an example of batch control operation, see Batch Control Operation Example on page 26.

Typical applications for alarms are low and high flow alarms or grand total limit alarms. Note that rate alarms are only enabled during a batching process, and deactivate when the processes is stopped.

The relays can also be set for sampling, where the relay will activate for a specific amount of time after a certain grand total has been reached (ie: 2 second sample relay activation every 100 gallons batched).

There are three basic ways the relays can be used:

1. Batch Control (Total)
2. High or Low Alarms for Rate or Grand Total
3. Sampling (Based on Grand Total and Sample Time)

### Relays Initialization

Batch control (total) relays will activate when the start function is enabled, such as when the START button is pressed. Rate alarm relays will enable and initialize to their programmed states when the batch process is started. Grand total alarm relays will initialize to their programmed state at controller power-up.

### Fail-Safe Operation

The following table indicates how the relays behave based on the fail-safe selection for each relay:

*Note: NO = Normally Open,  
NC = Normally Closed.  
This refers to the condition of  
the relay contacts when the  
power to the meter is off.*

| Fail-Safe Selection | Non-Alarm State |        | Alarm State |        | Power Failure                |
|---------------------|-----------------|--------|-------------|--------|------------------------------|
|                     | NO              | NC     | NO          | NC     |                              |
| Off                 | Open            | Closed | Closed      | Open   | Relays go to non-alarm state |
| On                  | Closed          | Open   | Open        | Closed | Relays go to alarm state     |

### Front Panel LEDs

The LEDs on the front panel provide status indication for the following:

| LED | Status  |
|-----|---------|
| 1   | Alarm 1 |
| 2   | Alarm 2 |
| 3   | Alarm 3 |
| 4   | Alarm 4 |

The controller is supplied with four alarm points that include front panel LEDs to indicate alarm conditions. This standard feature is particularly useful for alarm applications that require visual-only indication. The LEDs are controlled by the set and reset points programmed by the user. When the display reaches a set point for a high or low alarm, the corresponding alarm LED will turn on. When the display returns to the reset point the LED will go off. Note that rate alarms are only enabled during a batching process, and deactivate when the processes is stopped.

Latching relays, or relays with manual reset, are not recommended when using this controller for batch control, as the manual reset will not be acknowledged during a batch process, when the rate alarms are active. For information on latching and manual reset alarms, see the PD2-6200 instruction manuals available at [www.predig.com](http://www.predig.com).

### Automatic Reset (Auto)

In this application, the controller is set up for automatic reset (non-latching relay). Acknowledging the alarm while it is still present has no effect on either the LED or the relay. When the alarm finally goes away, the relay automatically resets and the LED also goes off.

Automatic reset only

| Condition       | LED | Relay |
|-----------------|-----|-------|
| Normal          | Off | Off   |
| Alarm           | On  | On    |
| Ack (No effect) | On  | On    |
| Normal          | Off | Off   |

### Pump Alternation Control Applications (ALtErn)

Pump alternation control is not recommended when using this controller for batch control, as it is used only in level applications, and not with rate, total, or batching applications. For information on using pump alternation control for level, see the PD2-6000 instruction manuals available at [www.predig.com](http://www.predig.com).

### Setting up the Interlock Relay (Force On) Feature

Relays 1-4 can be set up as interlock relays. To set up the relays for the interlock feature:

1. Access the *Setup – Relay – Action* menu and set the action to off.

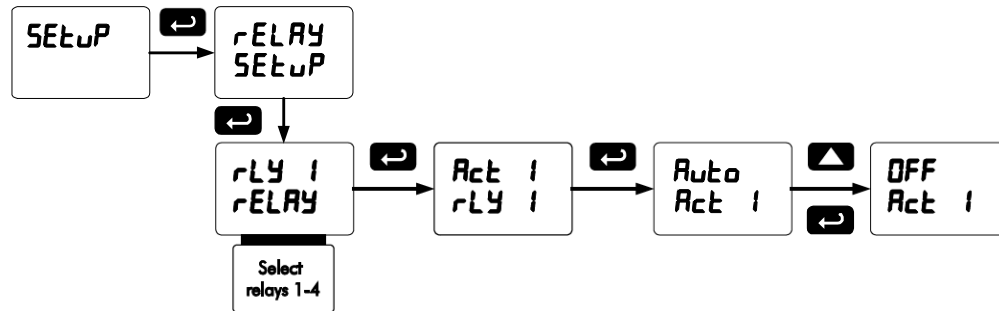

2. In the *Advanced features – User* menu program any of the digital inputs to *Force On* any of the internal relays (1-4).

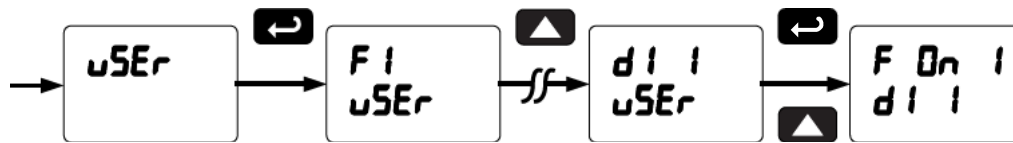

3. Connect a switch or dry contact between the +5V terminal and the corresponding digital input (dl-1 to dl-4) terminal.

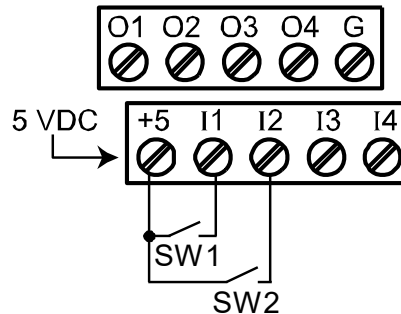

### Interlock Relay Operation Example

Relays 3 & 4 are configured to energize (their front panel LEDs are off) when SW1 & SW2 switches (above) are closed. If the contacts to these digital inputs are opened, the corresponding front panel LEDs flash indicating this condition. The processes being controlled by the interlock relay will stop, and will re-start only after the interlock relay is re-activated by the digital inputs (switches).

### Sample Relay Operation

The sampling function allows the operator to set a set point for a “sampling” relay. This can be done for the rate, total, or grand total. Each time the relay reaches the set point, it will close that relay’s contacts for a programmed period of time. A rate sampling relay will activate for the sample time ( $SR_{rate}$ ), up to 600.0 seconds, every time the set point rate is reached.

A total sampling relay will activate for the sample time ( $SR_{total}$ ), up to 600.0 seconds every time the process has batched the amount programmed for the set point, and every time this amount has been batched afterward. (See the diagram below for more details). The utility of this function can, of course, be expanded beyond sampling and be used whenever a timed relay output closure is required when the batch total interval reaches a certain set point.

### Scaling the 4-20 mA Analog Output ( $R_{out}$ )

The 4-20 mA analog output can be scaled to provide a 4-20 mA signal for any display range selected.

No equipment is needed to scale the analog output; simply program the display values to the corresponding mA output signal.

The *Analog Output* menu is used to program the 4-20 mA output based on display values.

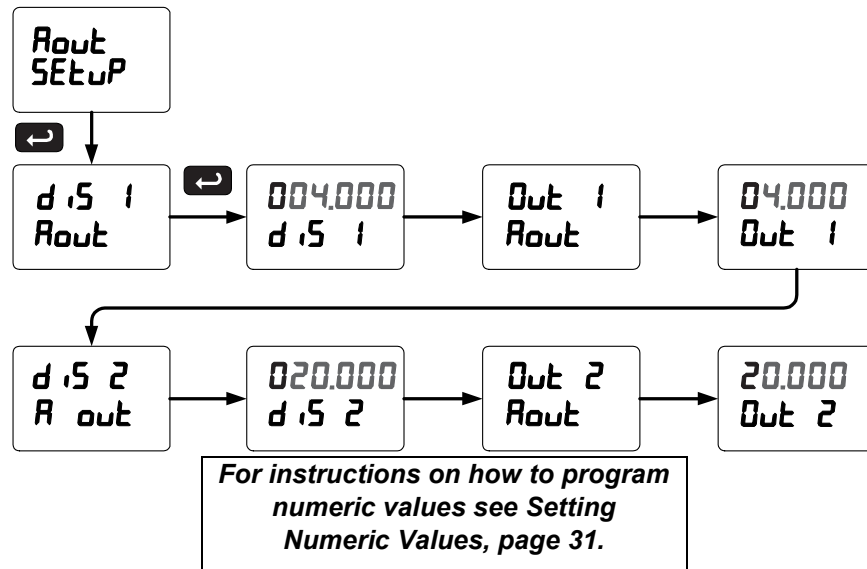

### Reset Menu ( $rESEt$ )

The *Reset* menu is used to reset the maximum or minimum reading (peak or valley) reached by the process; both may be reset at the same time by selecting “reset high & low” ( $rSt HL$ ). The tare value used to zero the display may be reset by selecting “reset tare” ( $rSt tr$ ).

### Control Menu ( $ContrL$ )

The *Control* menu is used to control the 4-20 mA analog output and the relays manually, ignoring the input. Each relay and analog output can be programmed independently for manual control. Selecting automatic control sets all relays and analog output for automatic operation.

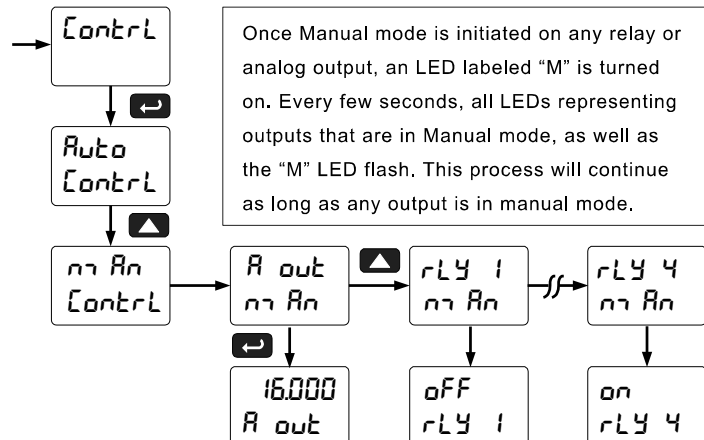

## Setting up the Password (PASS)

The *Password* menu is used for programming three levels of security to prevent unauthorized changes to the programmed parameter settings.

Pass 1: Allows use of function keys and digital inputs  
 Pass 2: Allows use of function keys, digital inputs and editing set/reset points  
 Pass 3: Restricts all programming, function keys, and digital inputs  
 Total: Prevents resetting the total manually  
 Gtotal: Prevents resetting the grand total manually.

## Protecting or Locking the Meter

Enter the *Password* menu and program a six-digit password.

For instructions on how to program numeric values see *Setting Numeric Values*, page 31.

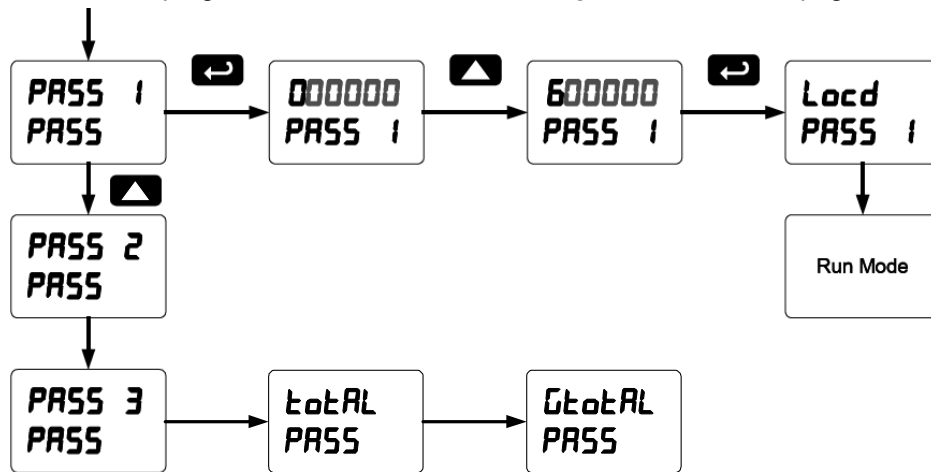

## Total Reset Password & Non-Resetable Total

The total and the grand total can be password-protected to prevent unauthorized total resets.

The grand total can be programmed as a non-resettable total by entering the password "050873".

 **Caution!** Once the Grand Total has been programmed as "non-resettable" the feature **cannot** be disabled.

## Making Changes to a Password Protected Meter

If the meter is password protected, the meter will display the message *Locd* (*Locked*) when the Menu button is pressed. Press the Enter button while the message is being displayed and enter the correct password to gain access to the menu. After exiting the programming mode, the meter returns to its password protected condition.

## Disabling Password Protection

To disable the password protection, access the *Password* menu and enter the correct password twice, as shown below. The meter is now unprotected until a new password is entered.

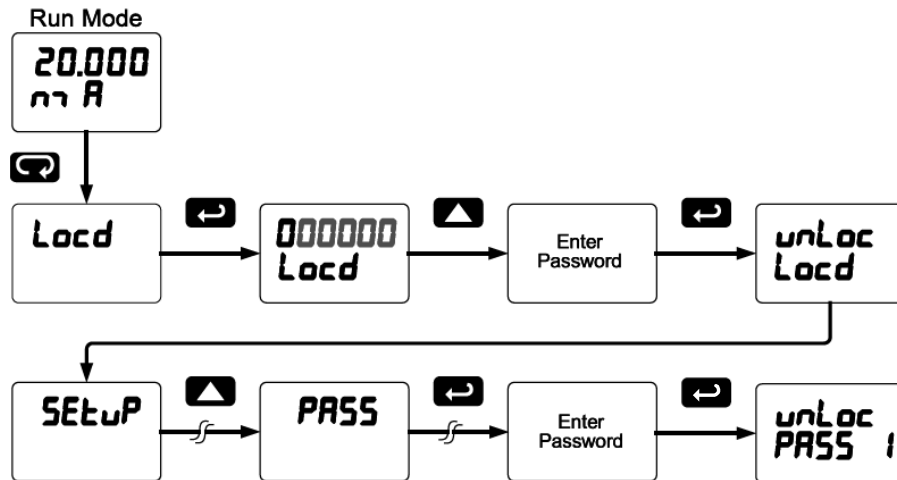

If the correct six-digit password is entered, the meter displays the message *unLoc* (*unlocked*) and the protection is disabled until a new password is programmed.

If the password entered is incorrect, the meter displays the message *Locd* (*Locked*) for about two seconds, and then it returns to Run Mode. To try again, press Enter while the *Locked* message is displayed.

### Did you forget the password?

The password may be disabled by entering a master password once. If you are authorized to make changes, enter the master password 508655 to unlock the meter.

## Advanced Operation and Programming

In addition to the functions described in Controller Operation on page 25, the following advanced operation and display features may be programmed. Configuring these features may disable some default batch controller features, or make running a batch operation impossible. These functions should only be used by users who are sure of their need in their application.

### Function Keys Operation

During operation, the programmable function keys operate according to the way they have been programmed in the *Advanced Features – User* menu. The following table shows the default setting for each of the function keys.

| Function Key/Button | Default Setting | Action           |
|---------------------|-----------------|------------------|
| F1/START            | StArt           | Start batch      |
| F2/BATCH            | PrESEt          | Change preset    |
| F3/STOP             | StoP            | Pause/stop batch |
| F4/Digital Input    | StStP           | Start/stop batch |

### Digital Input Operation

Five (5) digital inputs, F4-F8, come standard on the meter. These digital inputs are programmed identically to function keys F1, F2, and F3. The inputs are triggered with a contact closure to +5 (COM in the case of F4, see Digital I/O Connections on page 20 for details), or with an active low signal. During operation, digital inputs operate according to the way they are programmed in the *Advanced Features – User* menu.



**Only STOP Operation Enabled if a Batch is Running.**  
*During a batch process, the only function that can be performed is the pause/stop functions of the STOP button; the default programming of the F3 key. No other functions, including min/max display, manual alarm reset, or total reset, will function while a batch is running.*

## Advanced Setup and Calibration

### Multi-Point Calibration & Scaling

The controller is set up at the factory for 2-point linear calibration. The number of points for multi-point calibration/scaling is set up in the *Advanced Features* menu. Up to 32 linearization points may be selected. See page 53 for details.

### Maximum/Minimum Readings

The max & min readings (peak & valley) reached by the process can be displayed either continuously or momentary:

1. Display briefly by assigning to the digital inputs in the *User* menu.
2. Display continuously by assigning either display to max/min through the *Display* menu.



*Changing the programming of the F1-F3 function keys will disable the default batch operation of these keys, and is not recommended for batch control applications.*

Any of the digital inputs can be programmed to reset the max & min readings.

#### To display max/min readings continuously:

Assign either display to Max (d H i), Min (d Lo), or toggle between Max and Min (d HL) every 10 seconds.

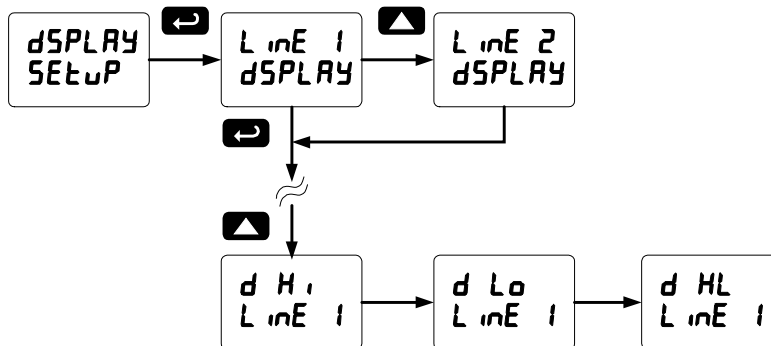

## Advanced Features Menu

To simplify the setup process, functions not needed for most applications are located in the *Advanced Features* menu.

Press and hold the Menu button for three seconds to access the advanced features of the meter. This cannot be done during a batch process as all functions other than STOP are disabled during a batch process, including the *Menu* button.

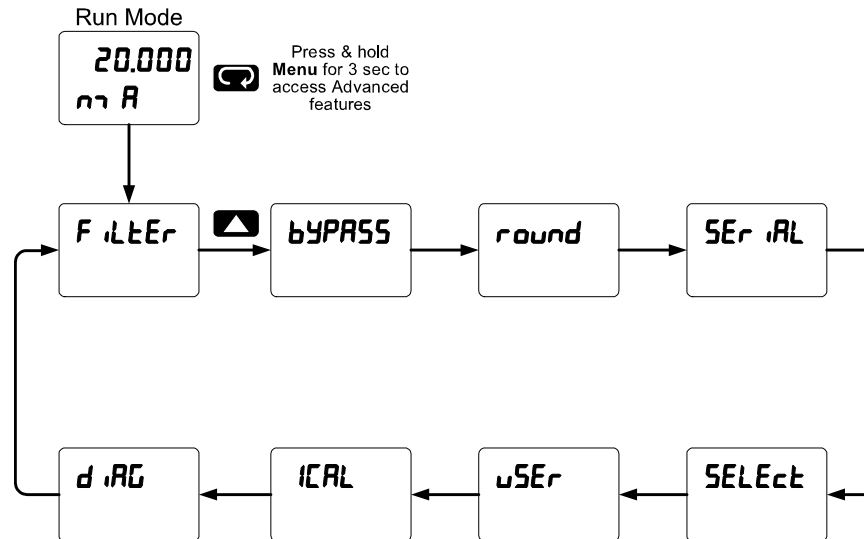

## Advanced Features Menu & Display Messages

The following table shows the functions and messages of the *Advanced Features* menu in the order they appear in the menu.

| Display  | Parameter                 | Action/Setting   |
|----------|---------------------------|--|
| F iLTER  | Filter                    | Set noise filter value   |
| bYPASS   | Bypass                    | Set filter bypass value  |
| round    | Round                     | Set the rounding value for display variables   |
| SEr iAL  | Serial                    | Set serial communication parameters  |
| SLAVE id | Slave ID                  | Set slave ID or meter address  |
| bRud     | Baud rate                 | Select baud rate   |
| tr dLY   | Transmit delay            | Set transmit delay for serial communication  |
| PRr tY   | Parity                    | Select parity: Even, Odd, or None with 1 or 2 stop bits                              |
| t-byt    | Time byte                 | Set byte-to-byte timeout   |
| SELEct   | Select                    | Enter the Select menu (function, cutoff, out)  |
| Functn   | Signal input conditioning | Select linear, square root, programmable exponent, or round horizontal tank function |
| L inERr  | Linear                    | Set meter for linear function and select number of linearization points              |
| no Pts   | Number of points          | Set PV1 for 2 to 32-point linearization<br>Set PV2 for 2 to 8-point linearization    |
| SqurRE   | Square root               | Set meter for square root extraction   |
| PrOG E   | Programmable exponent     | Set meter for programmable exponent and enter exponent value                         |
| CuTcOFF  | Cutoff                    | Set low-flow cutoff  |



| Display     | Parameter                   | Action/Setting   |
|-------------|-----------------------------|--|
| Count       | Count                       | Set total and grand total count direction  |
| Total       | Total Count                 | Set total to count up or down  |
| Grand Total | Grand Total Count           | Set grand total to count up or down  |
| Count Start | Count Start                 | Set start for total or grand total countdown   |
| RoutPr      | Analog output programming   | Program analog output parameters   |
| Source      | Source                      | Select source for the 4-20 mA output   |
| OverRng     | Overrange                   | Program mA output for display overrange  |
| UndrRng     | Underrange                  | Program mA output for display underrange   |
| brkRH       | Break                       | Set input break condition operation  |
| Force       | Force                       | Force analog output value for loop break   |
| Ignore      | Ignore                      | Ignore loop break condition  |
| MaxRH       | Maximum                     | Program maximum mA output allowed  |
| MinRH       | Minimum                     | Program minimum mA output allowed  |
| Cal         | Calibrate                   | Calibrate 4-20 mA output (internal reference source used for scaling the output)       |
| 4 mA        | 4 mA output                 | Enter mA output value read by milliamp meter with at least 0.001 mA resolution         |
| 20 mA       | 20 mA output                | Enter mA output value read by milliamp meter with at least 0.001 mA resolution         |
| User I/O    | User I/O                    | Assign function keys and digital I/O   |
| F1          | F1 function key             | Assign F1 function key   |
| F2          | F2 function key             | Assign F2 function key   |
| F3          | F3 function key             | Assign F3 function key   |
| F4          | F4 function                 | Assign F4 function (digital input)   |
| d1          | Digital input 1             | Assign digital input 1 – 4, if expansion modules are connected                         |
| d0          | Digital output 1            | Assign digital output 1 – 4, if expansion modules are connected                        |
| ICAL        | Internal source calibration | Enter internal source calibration (used for scaling the meter without a signal source) |
| Cal         | Current calibration         | Calibrate 4-20 mA current input (internal reference source used for scaling the input) |
| Cal         | Current low                 | Calibrate low current input (e.g. 4 mA)  |
| Cal         | Current high                | Calibrate high current input (e.g. 20 mA)  |
| V CAL       | Voltage calibration         | Calibrate voltage input  |
| V Cal       | Voltage low                 | Calibrate low voltage input (e.g. 0 V)   |
| V Cal       | Voltage high                | Calibrate high voltage input (e.g. 10 V)   |
| d iAG       | Diagnostics                 | Display parameter settings   |
| LED t       | LED test                    | Test all LEDs  |
| Info        | Information                 | Display software and S/N information   |
| Erase       | Erase                       | Delete the MeterView Pro installation files from the meter                             |

### Noise Filter (FILTER)

The noise filter is available for unusually noisy signals that cause an unstable process variable display. The noise filter averages the input signal over a certain period. The filter level determines the length of time over which the signal is averaged. The filter level can be set between 2 and 199. The higher the filter level, the longer the averaging time and so the longer it takes the display to settle to its final value. Setting the filter level to zero disables the filter function.

### Noise Filter Bypass (bypass)

The noise filter bypass changes the behavior of the meter so that small variations in the signal are filtered out but large abrupt changes in the input signal are displayed immediately. The bypass value determines the minimum amount of signal change to be displayed immediately. All signal changes smaller than the bypass value are filtered or averaged by the meter. The noise filter bypass may be set between 0.1 and 99.9% of full scale.

### Rounding Feature (round)

The rounding feature is used to give the user a steadier display with fluctuating signals. Rounding is used in addition to the filter function.

Rounding causes the display to round to the nearest value according the rounding selected. See examples below:

| Rounding Selection | Actual Value | Display Value | Actual Value | Display Value |
|--------------------|--------------|---------------|--------------|---------------|
| 1                  | 12.022       | 12.022        | 12.023       | 12.023        |
| 5                  | 12.022       | 12.020        | 12.023       | 12.025        |
| 10                 | 12.024       | 12.020        | 12.025       | 12.030        |

### Modbus RTU Serial Communications (SERIAL)

The meter is equipped with serial communications capability as a standard feature using Modbus RTU Serial Communication Protocol.

The meter may be connected to a PC for initial configuration via the onboard micro USB connection. For ongoing digital communications with a computer or other data terminal equipment, an RS-232, or RS-485 option is required; see *Ordering Information* on page 5 for details.

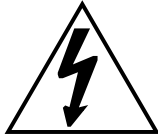

**Warning!**

**Do not connect any equipment other than Precision Digital's expansion modules, cables, or meters to the RJ45 M-LINK connector. Otherwise damage will occur to the equipment and the meter.**

**Do not disconnect the RJ45 connector located to the left of the power terminal block. Doing so will disable the onboard digital I/O, RS-485 serial communications, and M-Link functionality.**

*Note: More detailed instructions are provided with each optional serial communications adapter.*

*Note: Refer to the Modbus Register Tables located at [www.predig.com](http://www.predig.com) for details.*

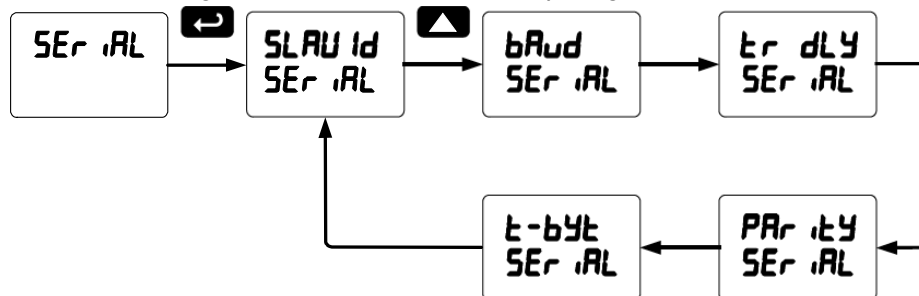

When using more than one meter in a multi-drop mode, each meter must be provided with its own unique address. The meter address (Slave ID) may be programmed between 1 and 247. The transmit delay may be set between 0 and 199 ms. The parity can be set to even, odd, or none with 1 or 2 stop bits.

### Select Menu (SELEct)

The *Select* menu is used to select the signal input conditioner applied to the input (linear, square root, programmable exponent, or round horizontal tank), low-flow cutoff, and analog output programming. The multi-point linearization is part of the linear function selection.

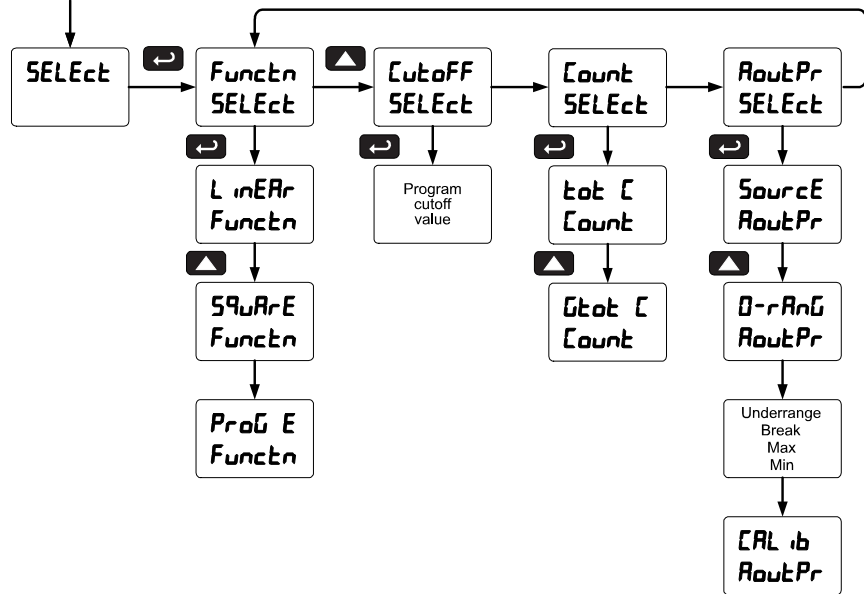

### Signal Input Conditioning (Functn)

The *Function* menu is used to select the signal input conditioner applied to the input: linear, square root, programmable exponent, or round horizontal tank volume calculation. The multi-point linearization is part of the linear function selection.

Meters are set up at the factory for linear function with 2-point linearization. The linear function provides a display that is linear with respect to the input signal.

#### Square Root Linearization (SQUARE)

The square root function can be used to linearize the signal from a differential pressure transmitter and display flow rate in engineering units.

#### Programmable Exponent Linearization (Programmable Exponent)

The programmable exponent can be used to linearize the signal from level transmitters in open-channel flow applications using weirs and flumes.

#### Multi-Point Linearization (LINEAR)

Meters are set up at the factory for linear function with 2-point linearization. Up to 32 linearization points can be selected for PV1 under the linear function. The multi-point linearization can be used to linearize the display for non-linear signals such as those from level transmitters used to measure volume in odd-shaped tanks or to convert level to flow using weirs and flumes with complex exponent.

If the dual-scale level feature has been selected, the menus for PV1 & PV2 are enabled. PV2 can be programmed with up to 8 linearization points.

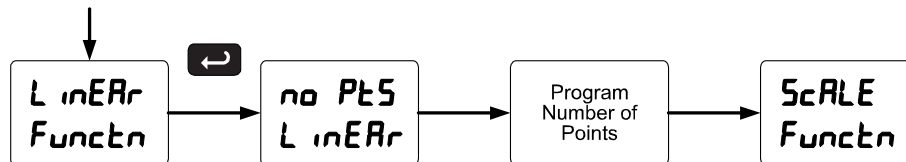

## Low-Flow Cutoff (LFF)

The low-flow cutoff feature allows the meter to be programmed so that the often-unsteady output from a differential pressure transmitter, at low flow rates, always displays zero on the meter.

The cutoff value may be programmed from 0 to 999999. The meter will display zero below the cutoff value. Programming the cutoff value to zero disables the cutoff feature.

## Total and Grand Total Count Direction (Count)

By default, the batch total and grand total count up during batch processes. Count parameter allows this to change. When set to count down, the batch total will count down from the preset to 0. When set to count down, the grand total will count down from a set value to zero.

## Analog Output Programming (AoutPr)

The *Analog Output Programming* menu is used to program the behavior of the 4-20 mA output. The following parameters and functions are programmed in this menu:

1. Source: Source for generating the 4-20 mA output (e.g. PV)
2. Overrange: Analog output value with display in overrange condition
3. Underrange: Analog output value with display in underrange condition
4. Break: Analog output value when loop break is detected
5. Max: Maximum analog output value allowed regardless of input
6. Min: Minimum analog output value allowed regardless of input
7. Calibrate: Calibrate the internal 4-20 mA source reference used to scale the 4-20 mA output

### Analog Output Source

The source for generating the 4-20 mA output may be assigned to the rate/process variable, total, grand total, maximum or minimum value reached by the rate/process, or one of the set points, or the Modbus PV input.

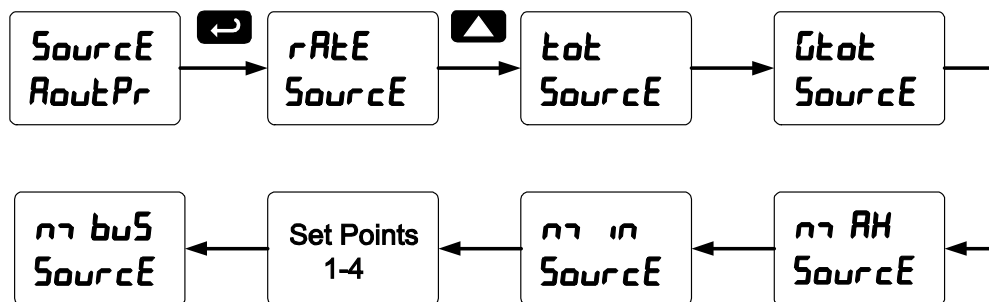

### Analog Output Calibration

To perform the analog output calibration it is recommended to use a milliamp meter with a resolution of at least 0.1  $\mu\text{A}$  to measure the output current. The values saved internally during this procedure are used for scaling the 4-20 mA output in the *Setup* menu.

## Programmable Function Keys User Menu (User)

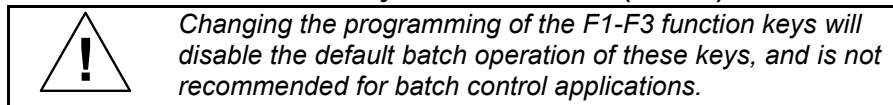

The *User* menu allows the user to assign the front panel function keys F1, F2, and F3, the digital input F4 (a digital input located on the signal input connector), and up to eight additional digital inputs to access most of the menus or to activate certain functions immediately (e.g. reset max & min, hold relay states, etc.). This allows the meter to be greatly customized for use in specialized applications.

Up to eight digital outputs can be assigned to a number of actions and functions executed by the meter (i.e. alarms, relay acknowledgement, reset max, min, or max & min, tare, and reset tare). The digital outputs can be used to trigger external alarms or lights to indicate these specific events.

## Function Keys & Digital I/O Available Settings

Refer to the following table for descriptions of each available function key or digital I/O setting.

| Display       | Description  | Display        | Description  |
|---------------|--|----------------|--|
| <b>StArt</b>  | Starts the batch process   | <b>d.SRBL</b>  | Disable the selected function key or digital I/O   |
| <b>StoP</b>   | Stops the batch process  | <b>RcH</b>     | Acknowledge all active relays that are in a manual operation mode such as auto-manual or latching  |
| <b>StStP</b>  | Allows the same function key to both start and stop the batch process  | <b>rESEt</b>   | Directly access the reset menu   |
| <b>rLY d</b>  | Disable all relays until a button assigned to <i>enable relays (rLY E)</i> is pressed  | <b>rSt t</b>   | Reset the total  |
| <b>rLY E</b>  | Enable all relays to function as they have been programmed   | <b>rSt Gt</b>  | Reset the grand total  |
| <b>0 Hold</b> | Hold current relay states and analog output as they are until a button assigned to <i>enable relays (rLY E)</i> is pressed   | <b>rSt bc</b>  | Reset the batch count  |
| <b>d Hold</b> | Hold the current display value, relay states, and analog output momentarily while the function key or digital input is active. The process value will continue to be calculated in the background. | <b>rSt Hi</b>  | Reset the maximum display value  |
| <b>Ln1 Hi</b> | Display maximum display value on line 1  | <b>rSt Lo</b>  | Reset the minimum display value  |
| <b>Ln1 Lo</b> | Display minimum display value on line 1  | <b>rSt HL</b>  | Reset the maximum & minimum display values   |
| <b>Ln1 HL</b> | Display maximum & minimum display values on line 1   | <b>rELAY</b>   | Directly access the relay menu   |
| <b>Ln2 Hi</b> | Display maximum display value on line 2  | <b>PrESEt</b>  | Change the preset value  |
| <b>Ln2 Lo</b> | Display minimum display value on line 2  | <b>SEt 2*</b>  | Directly access the set point menu for relay 2 (*through 8)  |
| <b>Ln2 HL</b> | Display maximum & minimum display values on line 2   | <b>αEnu</b>    | Mimic the menu button functionality (digital inputs only)  |
| <b>Ln2 Gt</b> | Display the grand total on line 2  | <b>rGt</b>     | Mimic the right arrow/F1 button functionality (digital inputs only)  |
| <b>Ln2 bc</b> | Display the batch count on line 2  | <b>uP</b>      | Mimic the up arrow/F2 button functionality (digital inputs only)   |
| <b>ContRL</b> | Directly access the control menu   | <b>EntEr</b>   | Mimic the enter/F3 button functionality (digital inputs only)  |
|               |  | <b>F On I*</b> | Force relay 1 (*through 4) into the on state. This function is used in conjunction with a digital input expansion module to achieve interlock functionality. See page 45 for details about interlock relays. |
|               |  | <b>ALAr I*</b> | Provide indication when alarm 1 (*through 8) has been triggered (digital outputs only)   |

## Internal Source Calibration (ICAL)

The meter is factory calibrated prior to shipment to read in milliamps and volts depending on the input selection. The calibration equipment is certified to NIST standards.

The use of calibrated signal sources is necessary to calibrate the internal source of the meter. The meter's internal source is what allows the user to scale the meter without applying a signal. Check calibration of the meter at least every 12 months. Each input must be recalibrated separately.

**Notes:**

1. If meter is in operation and it is intended to accept only one input type (e.g. 4-20 mA), recalibration of other input is not necessary.
2. Allow the meter to warm up for at least 15 minutes before performing the internal source calibration procedure.

The Internal calibration menu is part of the Advanced Features menu.

1. Press and hold the Menu button for three seconds to access the advanced features of the meter.
2. Press the Up arrow button to scroll to the *Internal calibration* menu (ICAL) and press Enter.
3. The meter displays either current calibration (IC Lo) or voltage calibration (IV CAL), according to the input setup. Press Enter to start the calibration process.

**Example of Internal Calibration for current input:**

4. The meter displays *low* input current message (IC Lo). Apply the low input signal and press Enter. The display flashes for a moment while the meter is accepting the low input signal.
5. After the display stops flashing, a number is displayed with the leftmost digit brighter than the rest. The bright digit is the active digit that can be changed by pressing the Up arrow button. Press the Right arrow button to move to the next digit.
6. Set the display value to correspond to the input signal being calibrated, typically 4.000 mA.
7. The display moves to the *high* input calibration (IC Hi). Apply the high input signal and press Enter.
8. Set the display for the high input calibration, in the same way as it was set for the low input calibration, typically 20.000 mA.

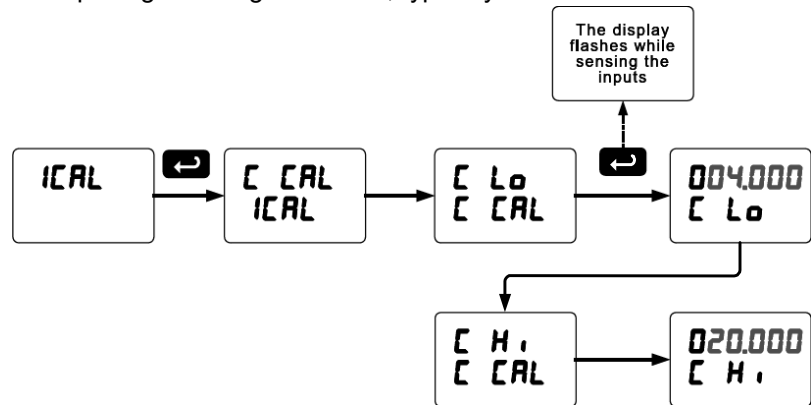

The graphic shows the calibration of the current input. The voltage input is calibrated in a similar way.

**Tips:**

- Low and high input signals can be any valid values within the range of the meter.
- Observe minimum input span requirements between input 1 and input 2.
- Low input should be less than high input signal.

**Error Message (Error)**

An error message indicates that the calibration or scaling process was not successful.

The error message might be caused by any of the following conditions:

1. Input signal is not connected to the proper terminals, or it is connected backwards.
2. Wrong signal selection in *Setup* menu.
3. Minimum input span requirements not maintained.

**Minimum Input Span**

The minimum input span is the minimum difference between input 1 and input 2 signals required to complete the calibration or scaling of the meter.

| Input Range | Input 1 & Input 2 Span |
|-------------|------------------------|
| 4-20 mA     | 0.15 mA                |
| ±10 VDC     | 0.01 VDC               |

## Troubleshooting

Due to the many features and functions of the meter, it's possible that the setup of the meter does not agree with what an operator expects to see. If the meter is not working as expected, refer to the *Diagnostics* menu and recommendations below.

### Diagnostics Menu (d iRG)

The *Diagnostics* menu is located in the *Advanced Features* menu, to access *Diagnostics* menu see *Advanced Features Menu*, page 50.

This menu allows the user to test the functionality of all the meter LEDs, check the meter's software and version information, and erase the MeterView Pro software installation files from the meter. Press the Enter button to view the settings and the Menu button to exit at any time.

For a description of the diagnostic messages, see *Advanced Features Menu*, page 50.

### Determining Software Version

To determine the software version of a meter:

1. Go to the *Diagnostics* menu (d iRG) and press Enter button.
2. Press Up arrow button and scroll to Information menu (InFd).
3. Press Enter to access the software number (5Fl) and version (vEr) information. Write down the information as it is displayed. Continue pressing Enter until all the information is displayed.
4. The meter returns to Run Mode after displaying all the settings.

### Reset Controller to Factory Defaults

When the parameters have been changed in a way that is difficult to determine what's happening, it might be better to start the setup process from the factory defaults.

#### Instructions to load factory defaults:

1. Enter the *Advanced Features* menu. See *Advanced Features Menu*, page 50.
2. Press Up arrow to go to *Diagnostics* menu
3. Press and hold Right arrow for three seconds, press Enter when display flashes rESEt. Note: If Enter is not pressed within three seconds, the display returns to the *Diagnostics* menu.
4. The meter goes through an initialization sequence (similar as on power-up), and loads the factory default settings.

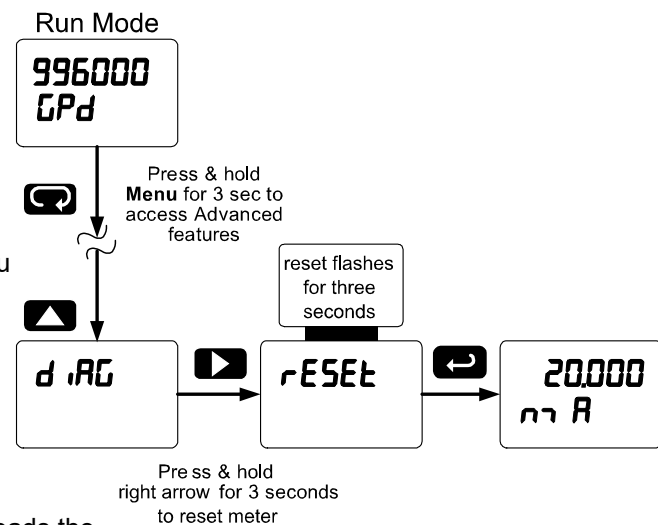

*Note: The dual-scale selection for some level applications (d-SCAL) is not reset to the single scale factory default. This can be changed using the Setup – Input menu.*



## Factory Defaults & User Settings

The following table shows the factory setting for most of the programmable parameters on the meter.

| Parameter                | Display         | Default Setting  |             |                 |
|--------------------------|-----------------|------------------|-------------|-----------------|
| Input type               | <i>inPut</i>    | 4-20 mA          |             |                 |
| Total                    | <i>totAL</i>    | Yes              |             |                 |
| Units                    | <i>un itS</i>   | Rate<br>mA       | Total<br>mA | Gr. Total<br>mA |
| Filter                   | <i>F ILtEr</i>  | 70               |             |                 |
| Bypass                   | <i>bYPASS</i>   | 0.2              |             |                 |
| Function                 | <i>FunctiOn</i> | Linear           |             |                 |
| Number of points         | <i>no Pts</i>   | 2                |             |                 |
| Programming              | <i>ProG</i>     | Scale            |             |                 |
| Input 1                  | <i>inP 1</i>    | 4.000 mA         |             |                 |
| Display 1                | <i>d is 1</i>   | 4.000            |             |                 |
| Input 2                  | <i>inP 2</i>    | 20.000 mA        |             |                 |
| Display 2                | <i>d is 2</i>   | 20.000           |             |                 |
| Rate decimal point       | <i>ddd.d</i>    | 3 places         |             |                 |
| Total decimal point      | <i>dddd.d</i>   | 1 place          |             |                 |
| Gr. total decimal point  | <i>dddd</i>     | 0 places         |             |                 |
| Cutoff value             | <i>CuToFF</i>   | 0.000 (disabled) |             |                 |
| Display line 1           | <i>LiNE 1</i>   | Rate/Process     |             |                 |
| Display line 2           | <i>LiNE 2</i>   | Total value      |             |                 |
| Display intensity        | <i>d-IntY</i>   | 8                |             |                 |
| Total time base          | <i>t t b</i>    | Second           |             |                 |
| Total conversion factor  | <i>t CF</i>     | 1.000            |             |                 |
| Batch mode               | <i>no dE</i>    | Manual           |             |                 |
| Grand total time base    | <i>Gt t b</i>   | Second           |             |                 |
| GTotal conversion factor | <i>Gt CF</i>    | 1.000            |             |                 |
| Grand total reset        | <i>Gt rSt</i>   | Manual           |             |                 |
| Total count up/down      | <i>tot C</i>    | Up               |             |                 |
| Grand tot count          | <i>Gtot C</i>   | Up               |             |                 |
| Relay 1 assignment       | <i>RS Un 1</i>  | Total            |             |                 |
| Relay 2 assignment       | <i>RS Un 2</i>  | Total            |             |                 |
| Relay 2 preclose         | <i>PrECLS</i>   | No               |             |                 |
| Relay 3 assignment       | <i>RS Un 3</i>  | Rate             |             |                 |
| Relay 4 assignment       | <i>RS Un 4</i>  | Rate             |             |                 |
| Relay 1 action           | <i>Act 1</i>    | Automatic        |             |                 |
| Batch preset             | <i>PrESEt</i>   | 100.0            |             |                 |



| Parameter            | Display       | Default Setting   |
|----------------------|---------------|-------------------|
| Relay 2 action       | <i>Rct 2</i>  | Automatic         |
| Relay 2 set point    | <i>SEt 2</i>  | 200.0             |
| Relay 3 action       | <i>Rct 3</i>  | Automatic         |
| Relay 3 set point    | <i>SEt 3</i>  | 3.000             |
| Relay 3 reset point  | <i>rSt 3</i>  | 2.500             |
| Relay 4 action       | <i>Rct 4</i>  | Automatic         |
| Relay 4 set point    | <i>SEt 4</i>  | 4.000             |
| Relay 4 reset point  | <i>rSt 4</i>  | 3.500             |
| Fail-safe relay 1    | <i>FLS 1</i>  | Off               |
| Fail-safe relay 2    | <i>FLS 2</i>  | Off               |
| Fail-safe relay 3    | <i>FLS 3</i>  | Off               |
| Fail-safe relay 4    | <i>FLS 4</i>  | Off               |
| Display 1 analog out | <i>d iS 1</i> | 4.000             |
| Output 1 value       | <i>Out 1</i>  | 4.000 mA          |
| Display 2 analog out | <i>d iS 2</i> | 20.000            |
| Output 2 value       | <i>Out 2</i>  | 20.000 mA         |
| Source analog output | <i>Source</i> | Rate/process      |
| Overrange output     | <i>O-rAnG</i> | 21.000 mA         |
| Underrange output    | <i>u-rAnG</i> | 3.000 mA          |
| Loop break output    | <i>brERH</i>  | 1.000 mA          |
| Maximum output       | <i>max RH</i> | 23.000 mA         |
| Minimum output       | <i>min RL</i> | 1.000 mA          |
| F1 function key      | <i>F 1</i>    | Reset max & min   |
| Password 1           | <i>PASS 1</i> | 000000 (unlocked) |
| Password 2           | <i>PASS 2</i> | 000000 (unlocked) |
| Password 3           | <i>PASS 3</i> | 000000 (unlocked) |
| Total password       | <i>totRL</i>  | 000000 (unlocked) |
| Grand total password | <i>GtotRL</i> | 000000 (unlocked) |

## Troubleshooting Tips

| Symptom  | Check/Action  |
|--|---|
| No display at all  | Check power at power connector  |
| Not able to change setup or programming, <code>L o c d</code> is displayed                   | Meter is password-protected, enter correct six-digit password to unlock   |
| Controller displays error message during calibration ( <code>Error</code> )                  | Check:<br>Signal connections<br>Input selected in <i>Setup</i> menu<br>Minimum input span requirements                |
| Controller displays<br><code>999999</code><br><code>-999999</code>                           | Check:<br>Input selected in <i>Setup</i> menu<br>Corresponding signal at Signal connector                             |
| Display is unstable  | Check:<br>Input signal stability and value<br>Display scaling vs. input signal<br>Filter and bypass values (increase) |
| Display response is too slow   | Check filter and bypass values  |
| Display reading is not accurate  | Check:<br>Signal input conditioner selected: Linear, square root, etc.<br>Scaling or calibration                      |
| Display does not respond to input changes, reading a fixed number                            | Check:<br>Display assignment, it might be displaying max, min, or set point.  |
| Display alternates between<br><code>H i</code> and a number<br><code>L o</code> and a number | Press Menu to exit max/min display readings.  |
| Relay operation is reversed  | Check:<br>Fail-safe in <i>Setup</i> menu<br>Wiring of relay contacts  |
| Relay and status LED do not respond to signal  | Check:<br>Relay action in <i>Setup</i> menu<br>Set and reset points   |
| Flashing relay status LEDs   | Relays in manual control mode or relay interlock switches opened.   |
| Controller not communicating with application programs                                       | Check:<br>Serial adapter and cable<br>Serial settings<br>Controller address and baud rate                             |
| If the display locks up or the controller does not respond at all                            | Cycle the power to reboot the microprocessor.   |
| Other symptoms not described above   | Call Technical Support for assistance.  |

*Note: Certain sequences of events can cause unexpected results. To solve these issues, it is best to start fresh from factory defaults and map changes ahead of time, rather than at random.*

*This Page Intentionally Left Blank*

## How to Contact Precision Digital

- For Technical Support, please  
Call: (800) 610-5239 or (508) 655-7300  
Fax: (508) 655-8990  
Email: [support@predig.com](mailto:support@predig.com)
- For Sales Support or to place an order, please  
contact your local distributor or  
Call: (800) 343-1001 or (508) 655-7300  
Fax: (508) 655-8990  
Email: [sales@predig.com](mailto:sales@predig.com)
- For the latest version of this manual, please visit  
[www.predig.com](http://www.predig.com)

