

STANDARD SYSTEM

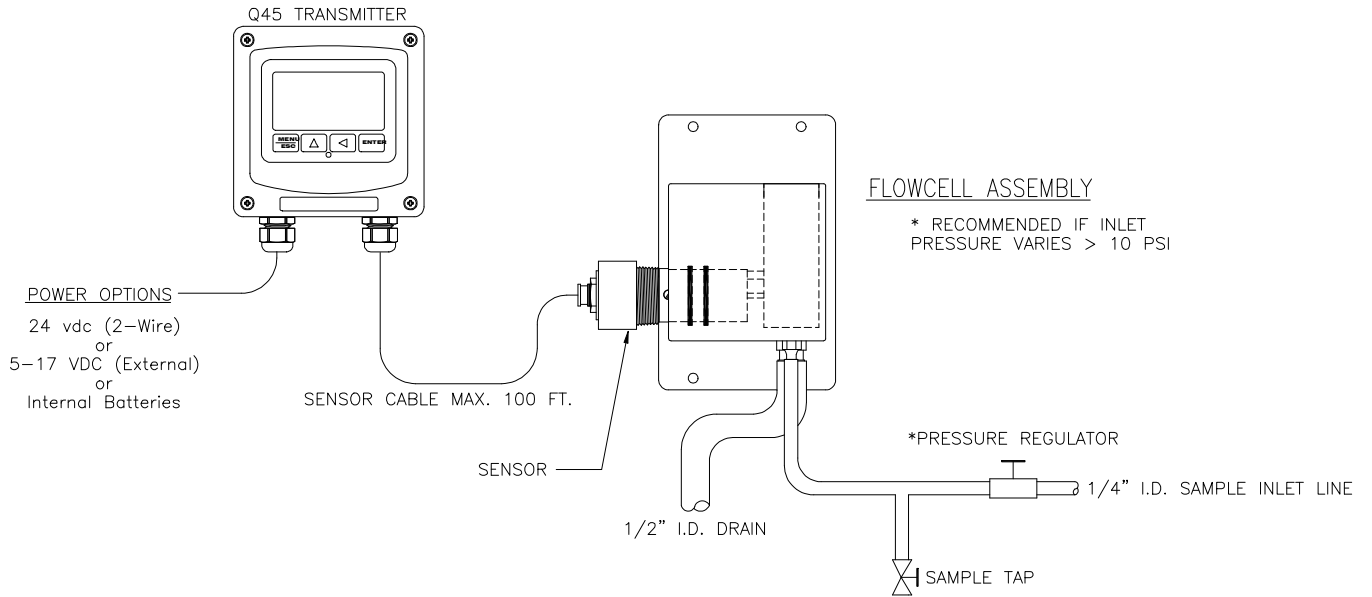

ATI-0730

SYSTEM w/Q22 pH SENSOR

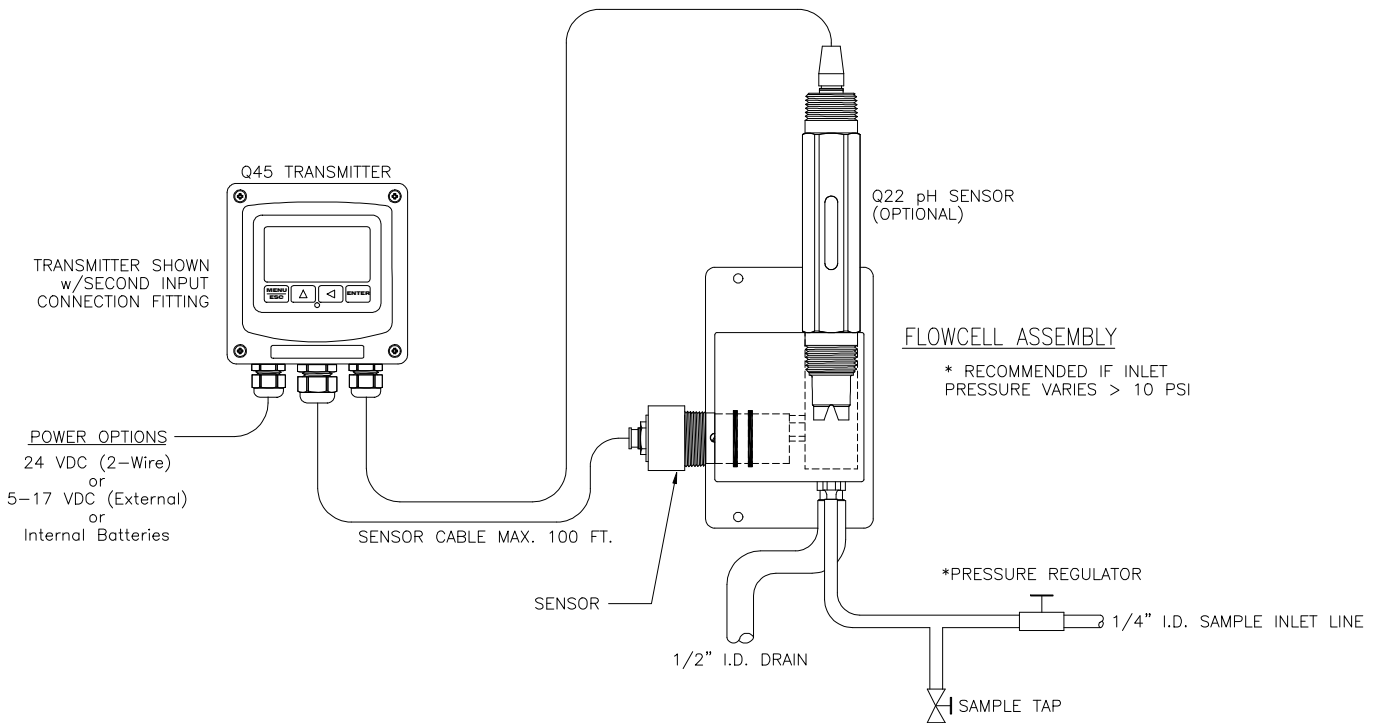

ATI-0648

SYSTEM w/pH (BAYONET STYLE) PROBE

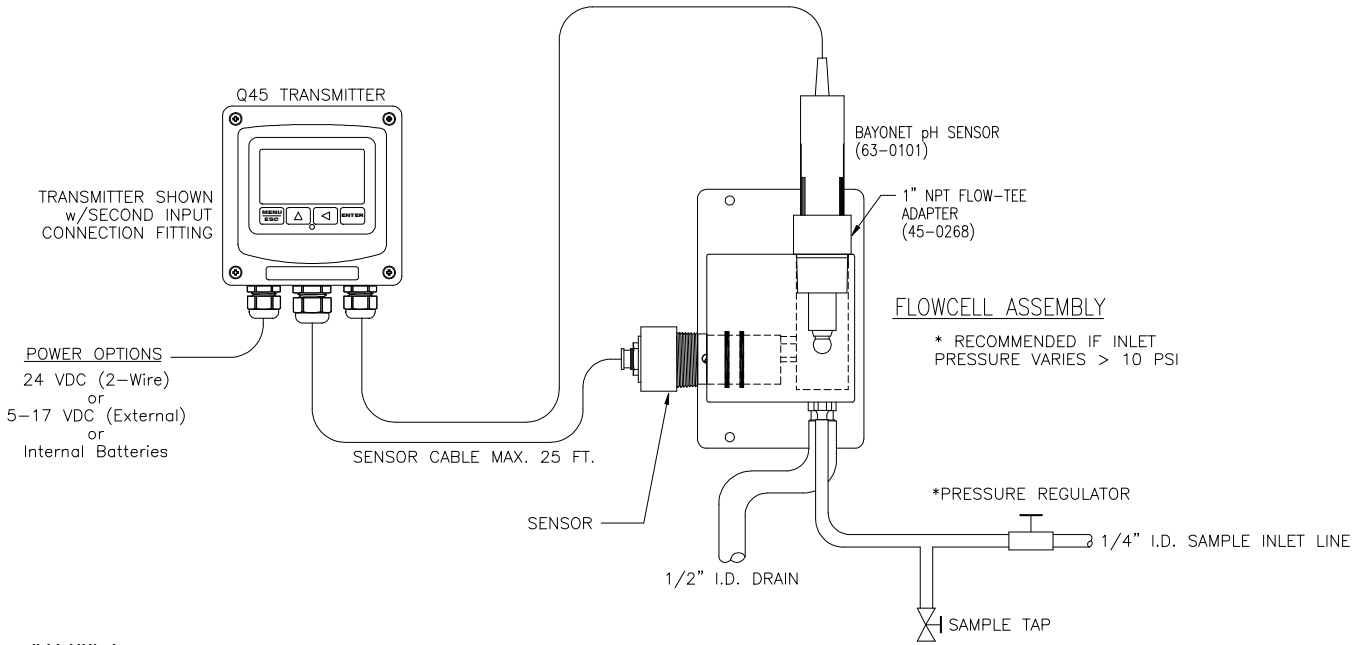

A11-U863

SYSTEM w/SEALED FLOWCELLS

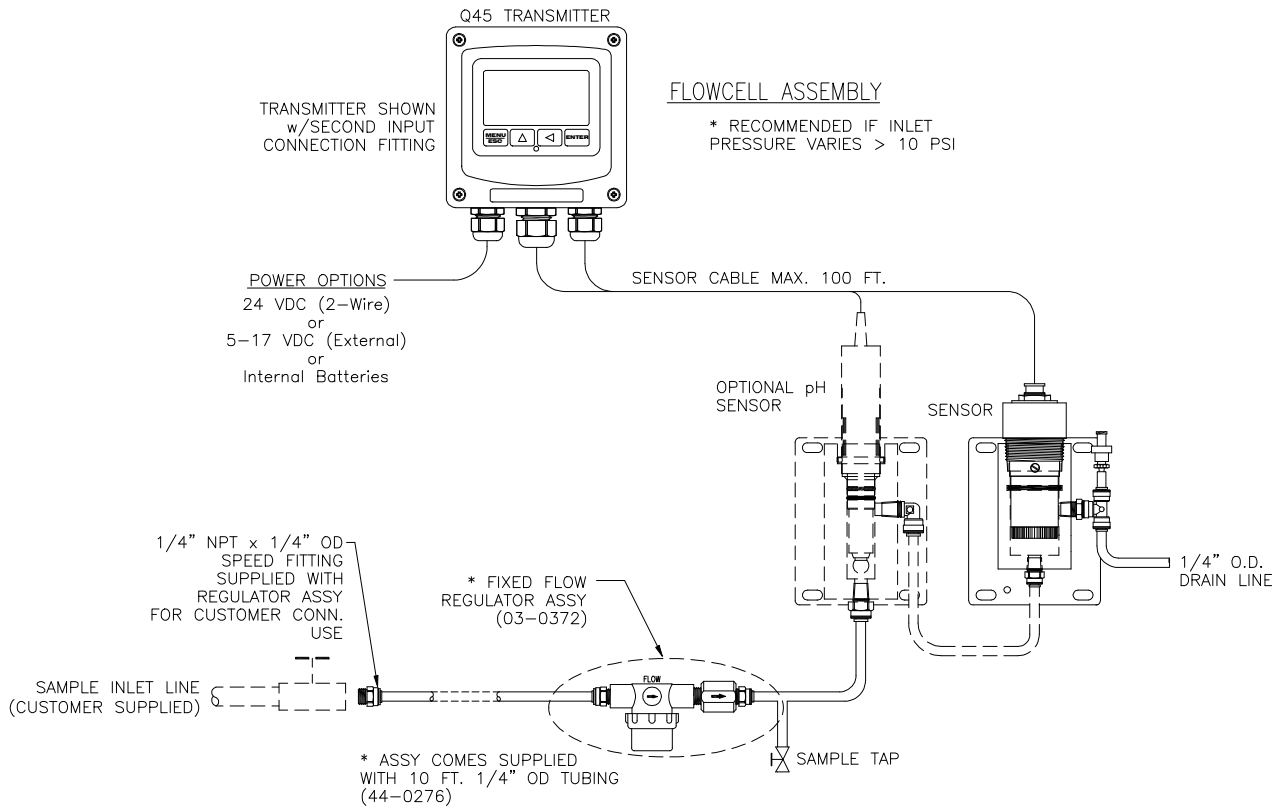

ATI-0891

2-WIRE VERSION or REMOTE DC MODELS

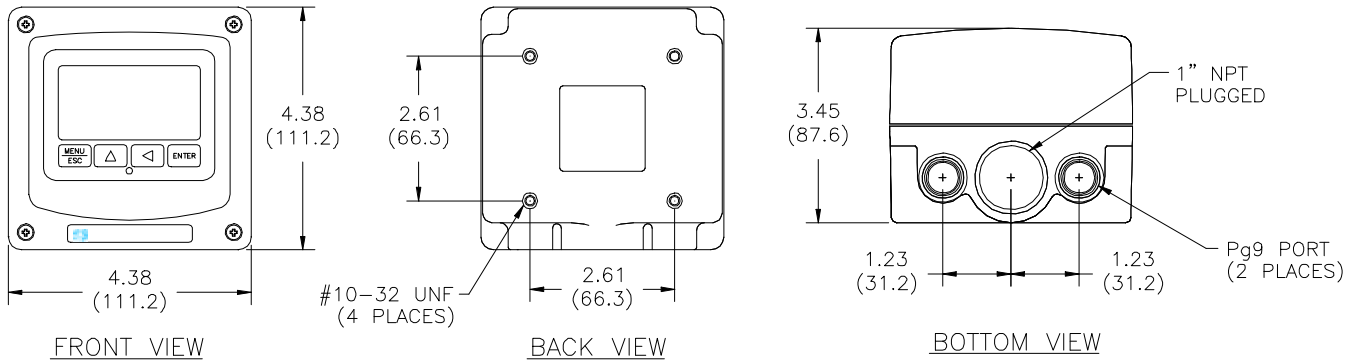

ATI-0655

NOTE: JUNCTION BOXES HAVE SAME DIMENSIONS AS 2-WIRE TRANSMITTER

BATTERY POWERED MODEL

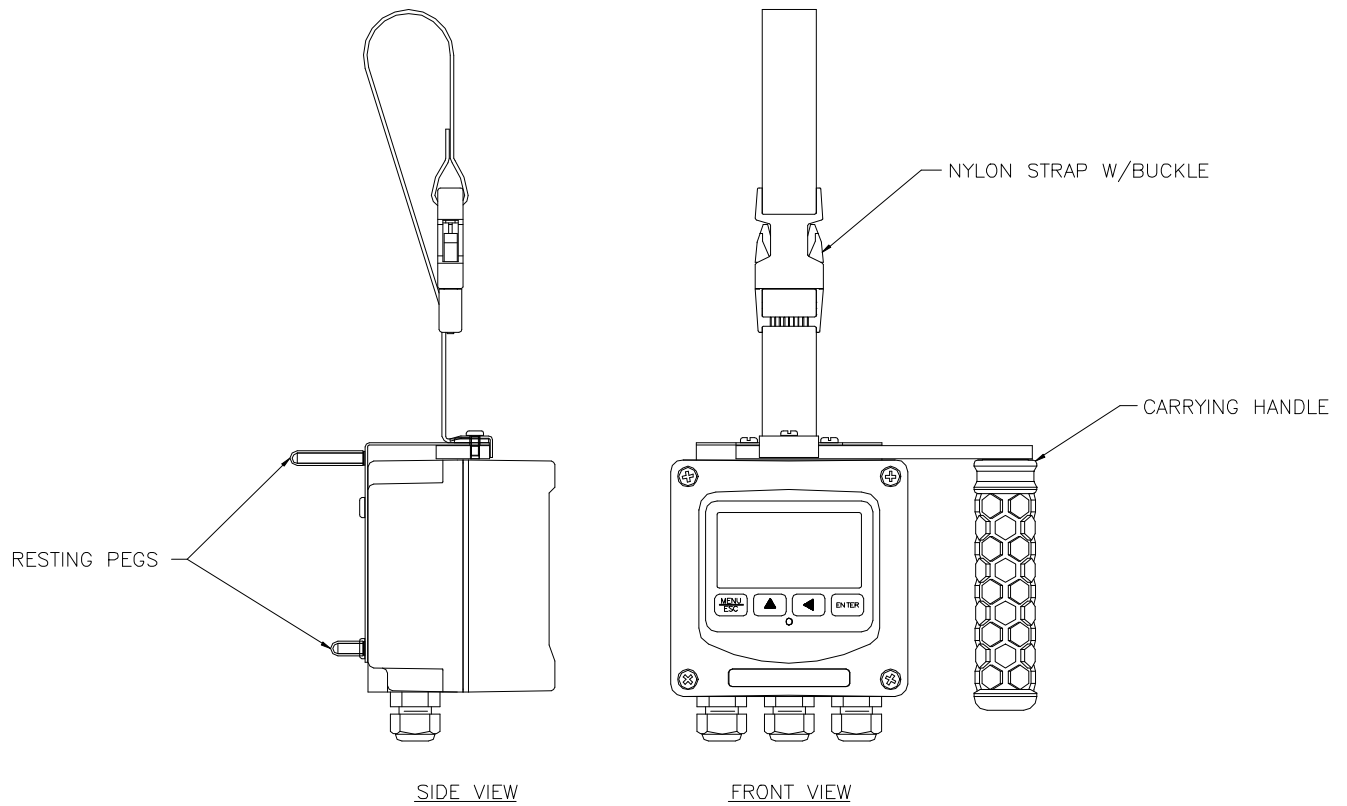

ATI-0688

WALL MOUNTING

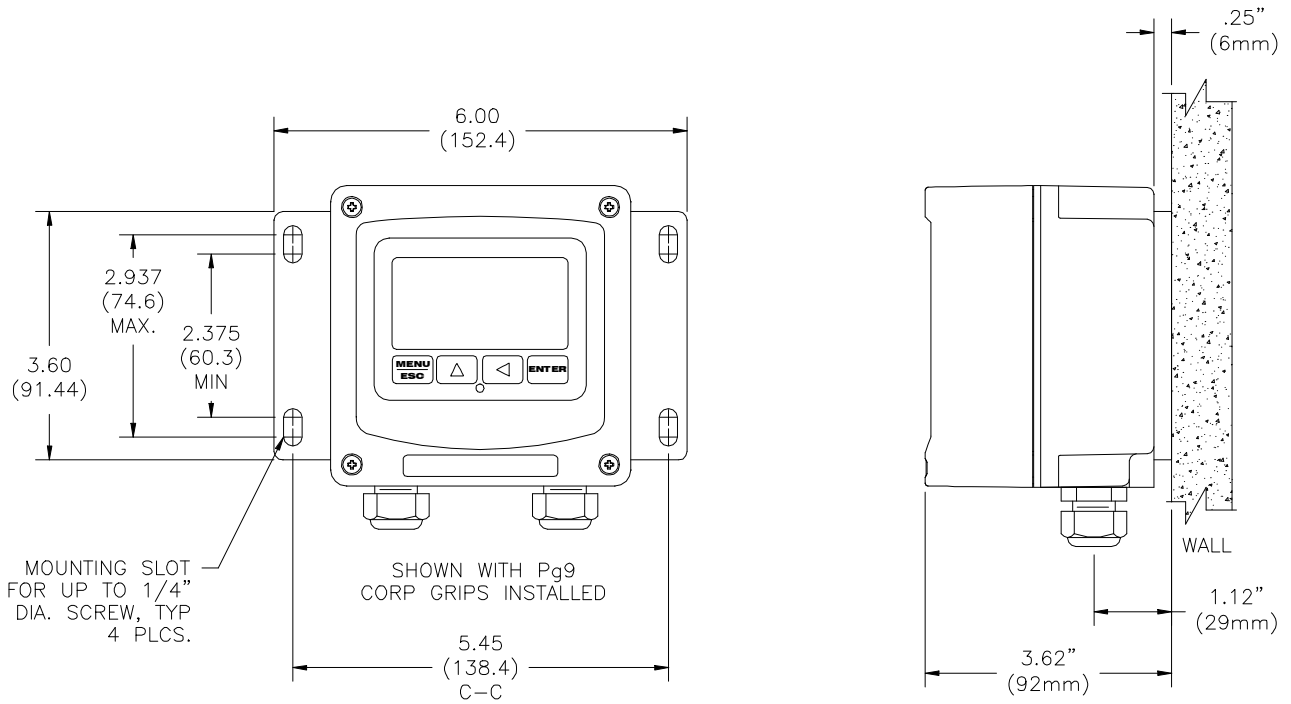

ATI-1033

PIPE MOUNTING

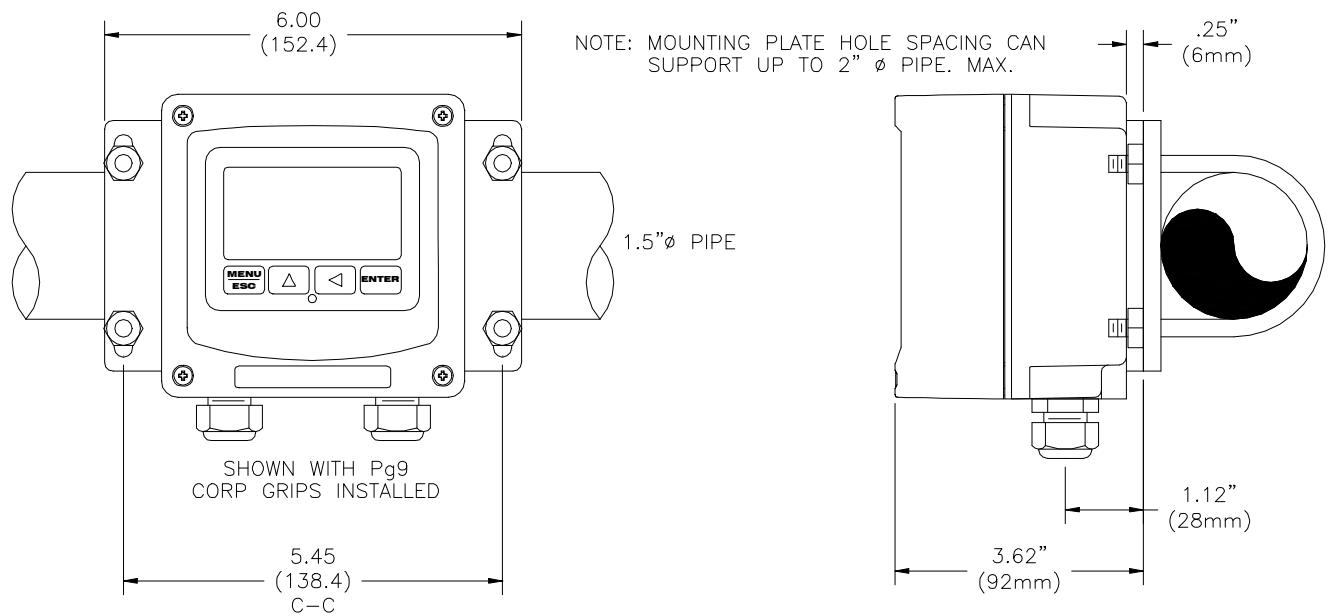

NOTE: PLATE MAY BE TURNED 90° FOR VERTICAL PIPE MOUNTING

ATI-1034

INTERNAL BATTERY CONFIGURATION

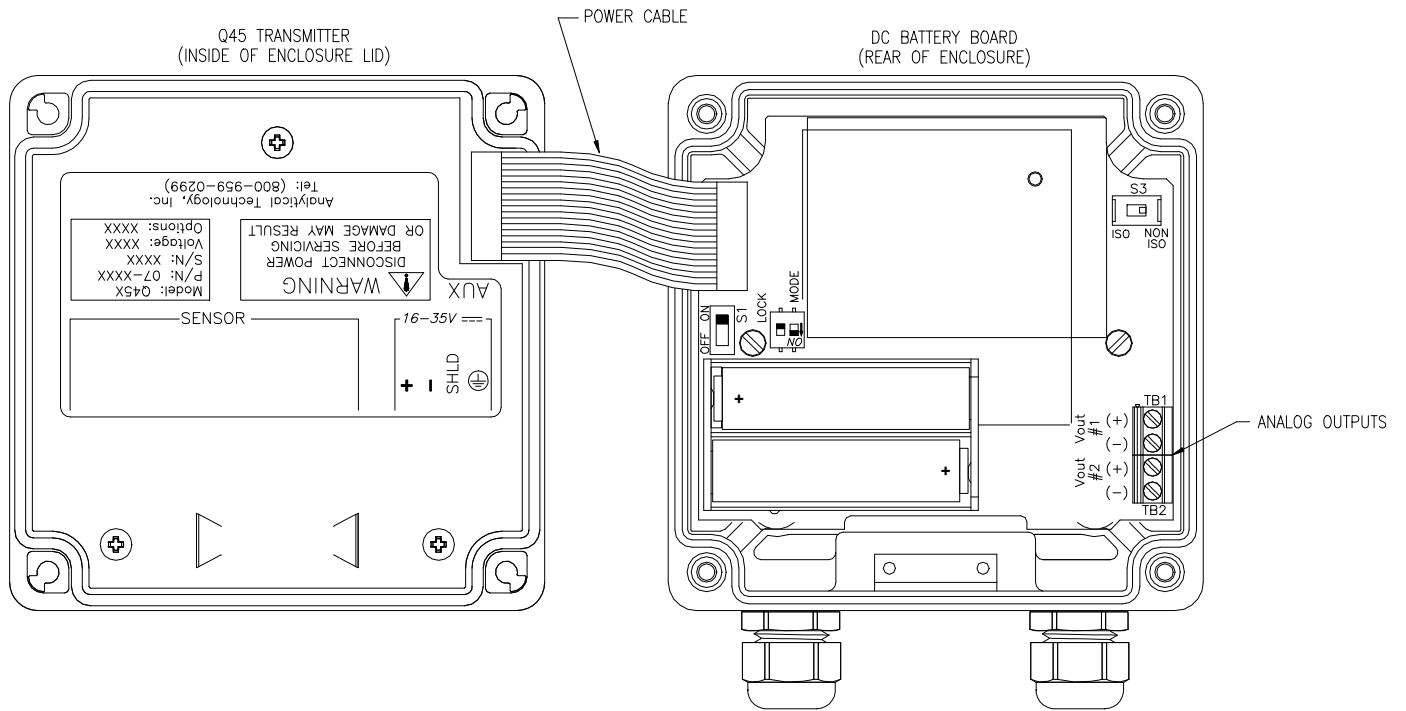

ATI-0827b

FLOW SENSOR DIMENSIONS & OVERFLOW CELL INSTALLATION

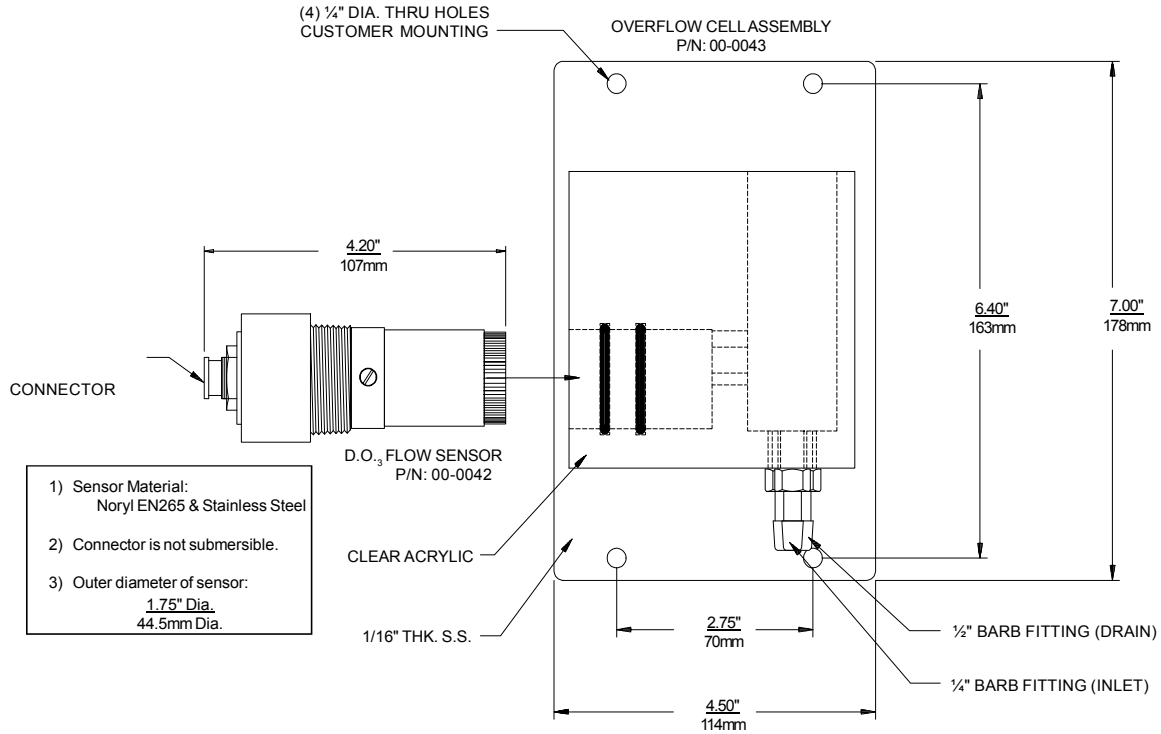

ATI-0196

**CI2 SEALED FLOWCELL ASSEMBLY
(00-1522)**

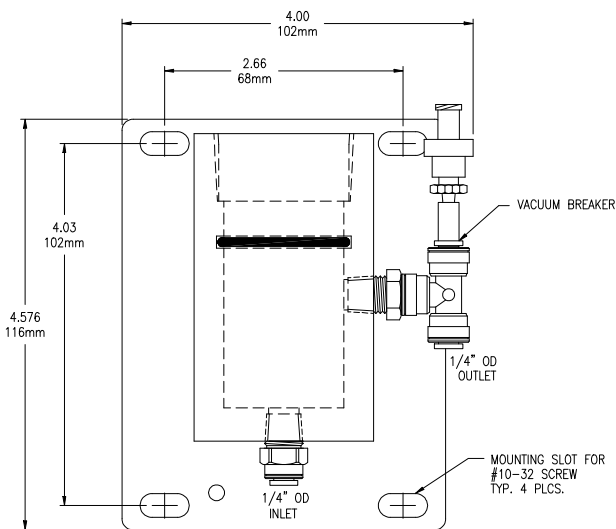

**pH SEALED FLOWCELL ASSEMBLY
(00-1527)**

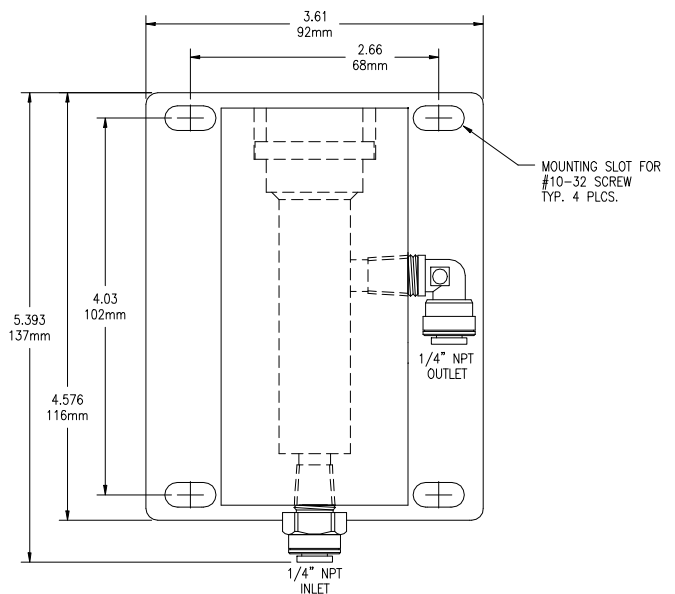

Material: Acrylic
Mounting Plate: PVC

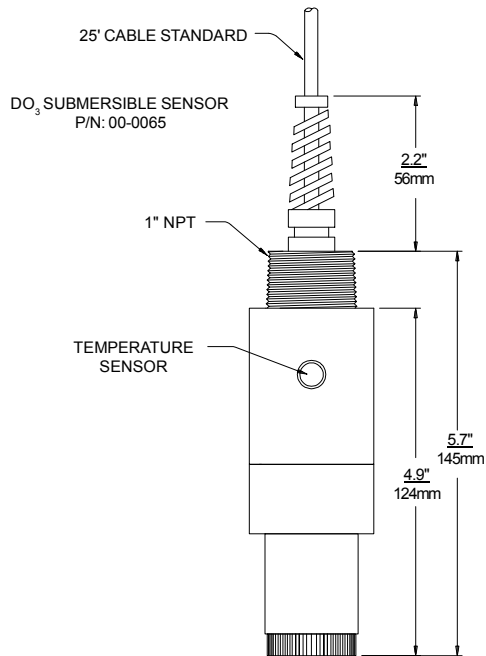
SUBMERSIBLE SENSOR DIMENSIONS

ATI-004

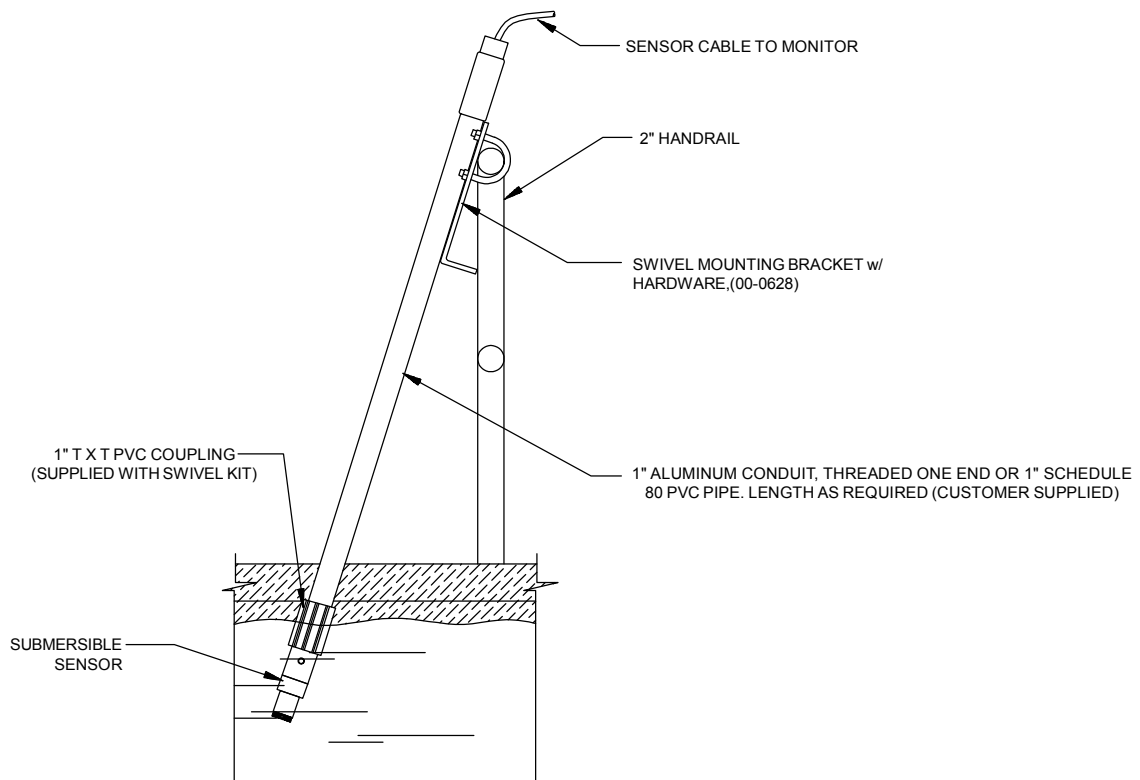
SUBMERSIBLE SENSOR INSTALLATION

ATI-0155

ELECTRICAL CONNECTIONS - 2-WIRE TRANSMITTER

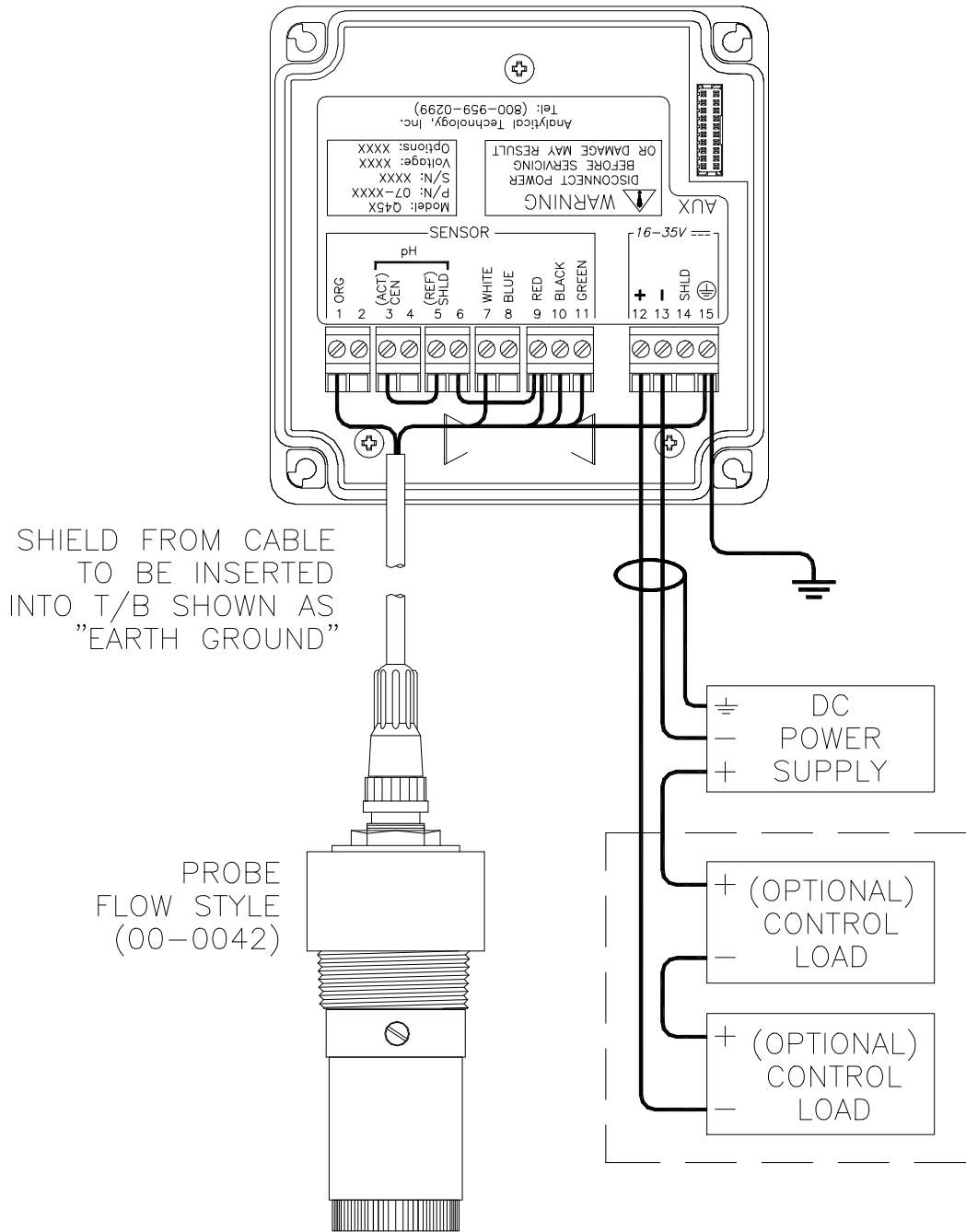

- NOTES:** 1. Voltage between Terminals 12 & 13 MUST be between 16 & 35 VDC.
 2. Earth ground into Terminal 15 is HIGHLY recommended. This connection can greatly improve stability in electrically noisy environments.

SENSOR CONNECTIONS - REMOTE JUNCTION BOX

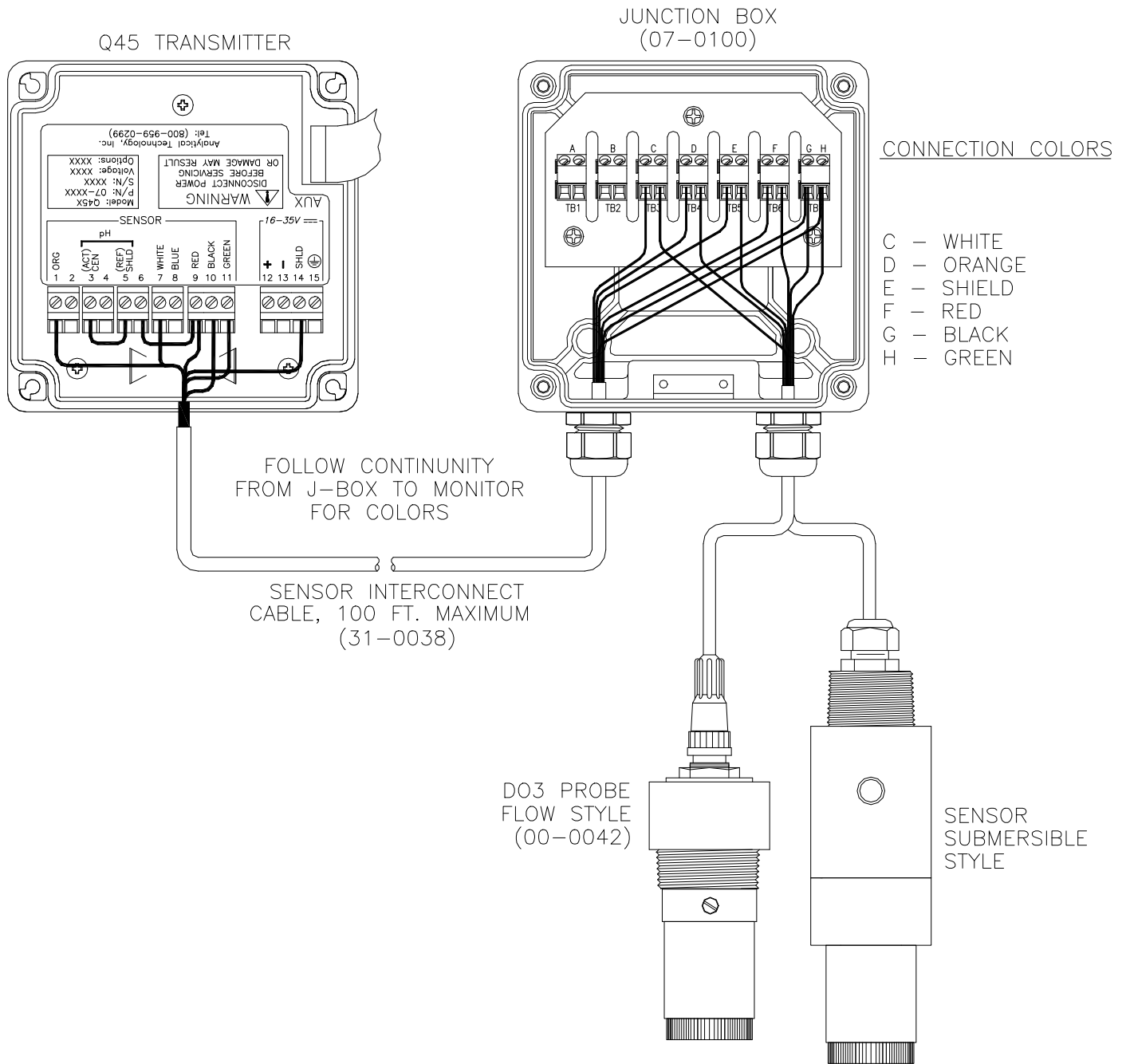

ATI-0731

Q22 pH SENSOR DIMENSIONS

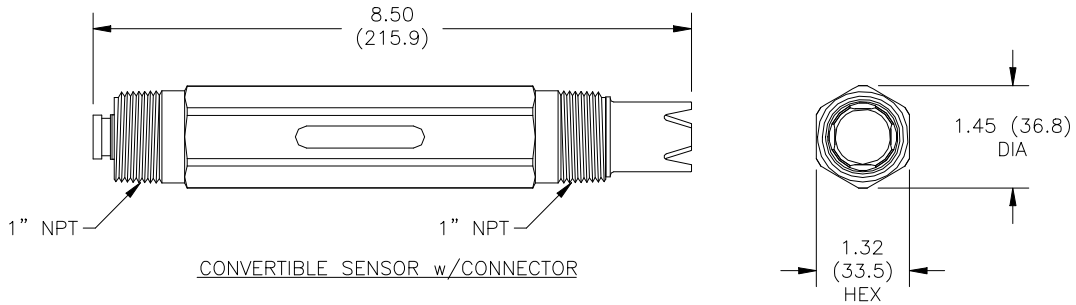

pH SENSOR (BAYONET STYLE) DIMENSIONS

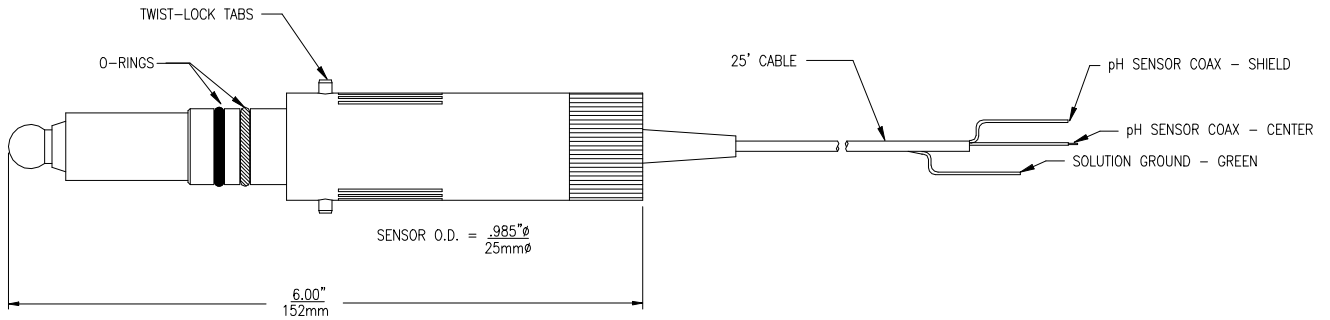

SPECIAL APPLICATION FLOWCELLS (CONSULT FACTORY)

- 1) Sensor Material: Noryl EN265 & Stainless Steel
- 2) Connector is not submersible.
- 3) Outer diameter of sensor: 1.75" Dia. / 44.5mm Dia.

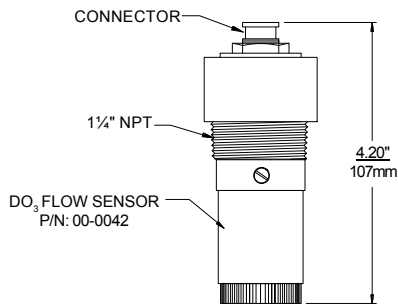

- Flow "T":
- 1) Max. 50 PSI for Flow "T" operation.
 - 2) Use Teflon tape to seal In-Line Sensor.
- Low Volume Flowcell:
- 1) Material: Clear Acrylic

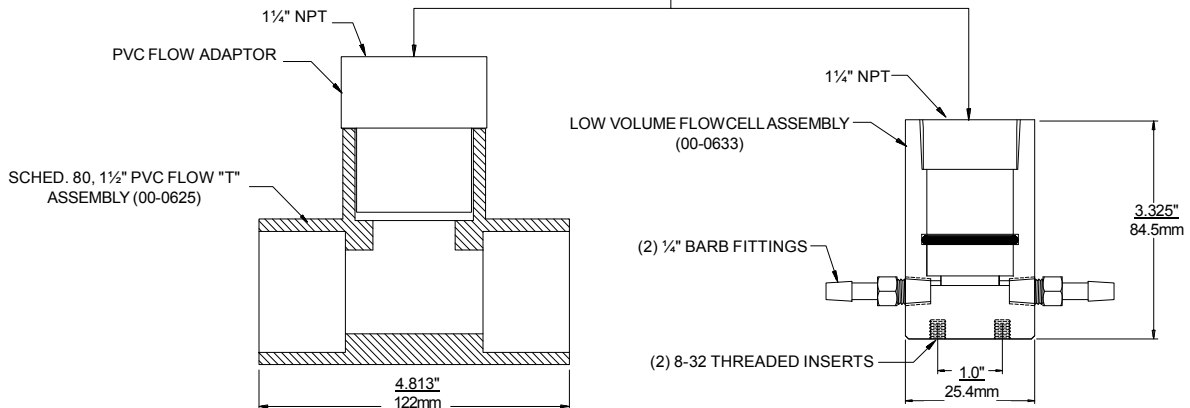

OPTIONAL pH SENSOR CONNECTIONS

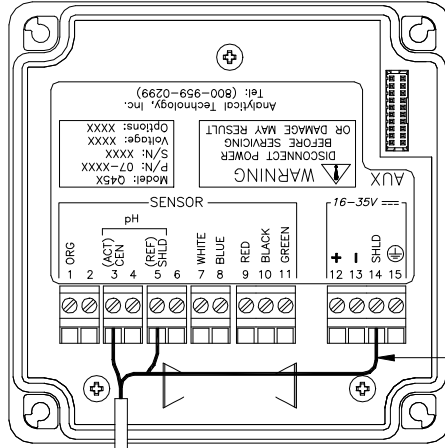

DRAIN WIRE

(07-0096) SENSOR CONNECTIONS

- RED - 3
- BLACK - 5
- SHIELD - 14

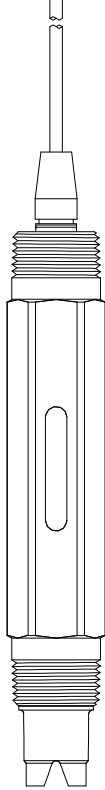

(63-0101) SENSOR CONNECTIONS

- 3 - CENTER COND.
- 5 - SHIELD (BRAID)
- 7 - GREEN

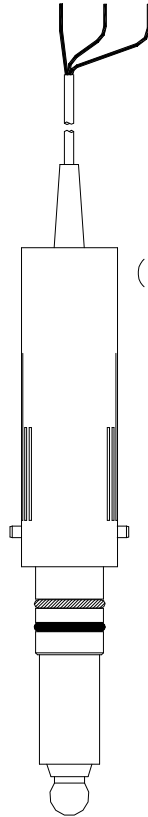

SENSOR CONNECTIONS - DO₃ / pH WITH JUNCTION BOX

(63-0101) Bayonet Style pH Probe CANNOT be used in a remote application

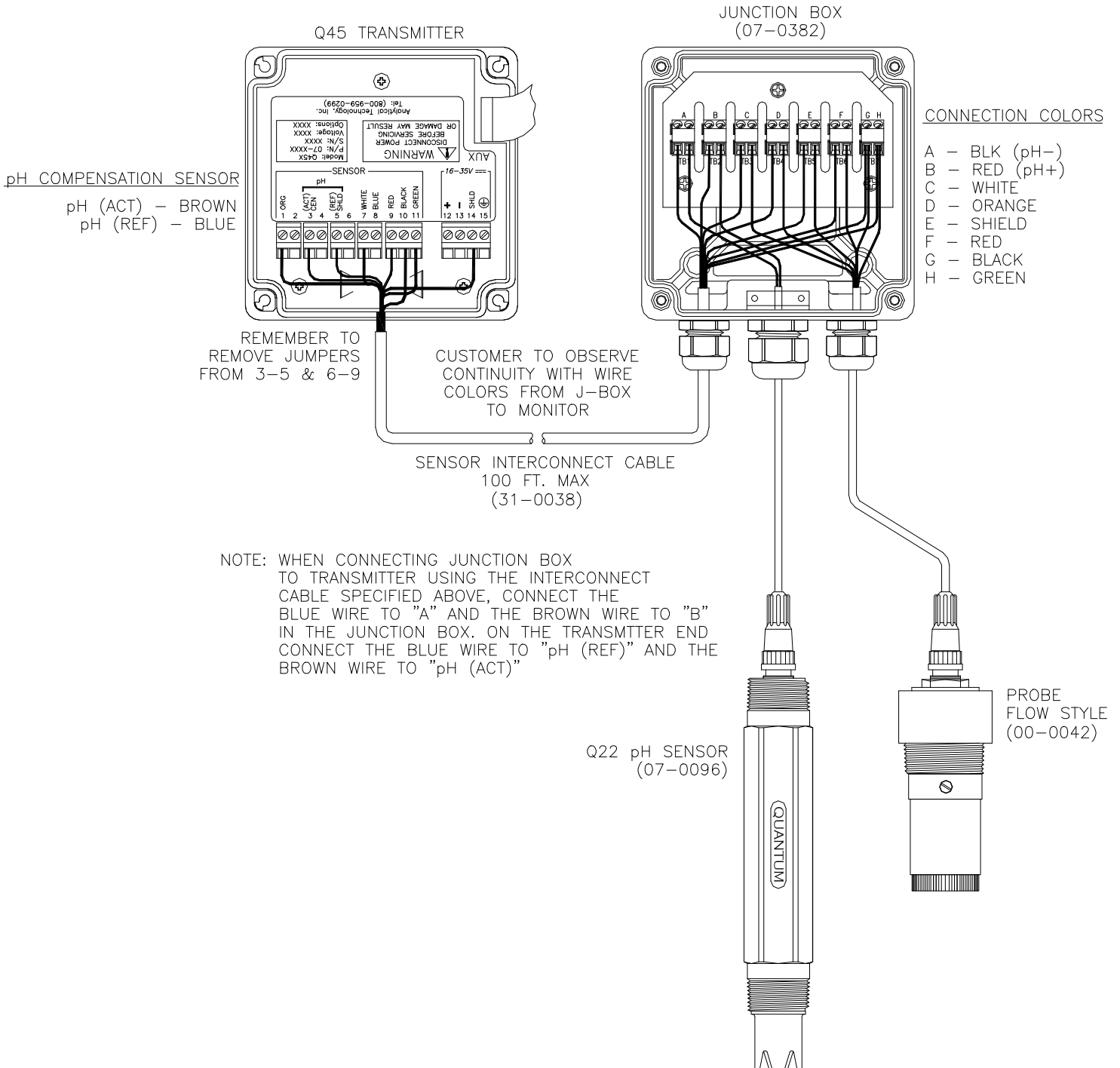

ATI-0102