

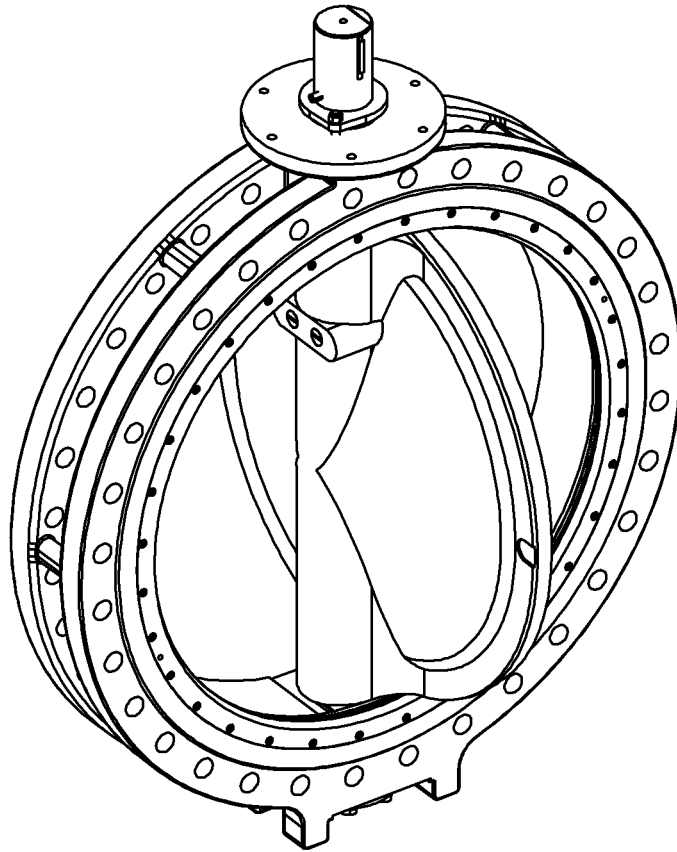

**DeZURIK 24" and Larger
BHP High Performance
Butterfly Valves
WITH (FB) FYRE-BLOCK® SEAT**



Instruction D10497
August 2018

DeZURIK

BHP High Performance Butterfly Valves

(S2, S3, S5, AA, HC, ML, T2 & T5 Shafts)

Instructions

These instructions provide information about High Performance Butterfly Valve. They are for use by personnel who are responsible for installation, operation and maintenance of High Performance Butterfly Valve.

Safety Messages

All safety messages in the instructions are flagged with an exclamation symbol and the word Caution, Warning or Danger. These messages indicate procedures that must be followed exactly to avoid equipment damage, personal injury or death.

Safety label(s) on the product indicate hazards that can cause equipment damage, personal injury or death. If a safety label becomes difficult to see or read, or if a label has been removed, please contact DeZURIK for replacement label(s).



WARNING!

Personnel involved in the installation or maintenance of valves should be constantly alert to potential emission of pipeline material and take appropriate safety precautions. Always wear suitable protection when dealing with hazardous pipeline materials. Handle valves, which have been removed from service with suitable protection for any potential pipeline material in the valve.

Inspection

Your BHP High Performance Butterfly Valve has been packaged to provide protection during shipment; however, it can be damaged in transport. Carefully inspect the unit for damage upon arrival and file a claim with the carrier if damage is apparent.

Parts

Recommended spare parts are listed on the assembly drawing. These parts should be stocked to minimize downtime.

Order parts from your DeZURIK sales representative, or directly from DeZURIK. When ordering parts, please include the 7-digit part number and 4-digit revision number (example: **9999999R000**) located on the data plate attached to the valve assembly. Also include the part name, the assembly drawing number, the balloon number and the quantity stated on the assembly drawing.

DeZURIK Service

DeZURIK service personnel are available to install, maintain and repair all DeZURIK products. DeZURIK also offers customized training programs and consultation services.

For more information, contact your local DeZURIK sales representative or visit our website at www.dezurik.com.

Table of Contents

Description	4
Handling	4
Installing Valve	4
Recommendations.....	4
Operation	6
Required Tools.....	6
Lubrication.....	6
Adjusting Packing.....	6
Drawings	7
Replacing Packing.....	8
Carbon Graphite Packing Option (G1).....	8
Torque Specification.....	9
Seat Replacement.....	10
Removing Valve From Pipeline	10
Replacing the Seat	10
Fyre-Block® Seat Options (TTS2 and RTS2).....	11
Valve Disassembly.....	12
Bearing Replacement.....	12
Nickel Stainless Bearings (Option NS)	12
Valve Reassembly.....	13
Troubleshooting	15

Description

The BHP High Performance Butterfly Valve is designed for on-off and throttling applications in the chemical, power, paper, air conditioning, petroleum and refining industries.

A choice of body styles, ratings, seat and packing options, materials, actuators and accessories is available in valve sizes from 24 - 60" (600–1500mm). Pressure and temperature ratings are shown on the valve data plate.

Handling

Lifting the valve improperly may damage it. Do not fasten lifting devices to the actuator, disc or through the seat opening in the body. Lift the valve with slings, chains or cables fastened around the valve body, or fastened to bolts or rods through bolt holes in the flanges.

Installing Valve



WARNING!

Metric fasteners should not be used with ASME Class 150/300 bolt holes and flange bolt patterns. If you use metric fasteners with ASME Class 150/300 bolt holes and flange bolt patterns, it may lead to product failure, injury, and loss of life. DeZURIK Inc. disclaims all liability associated with the use of metric fasteners with ASME Class 150/300 bolt holes and flange patterns, including but not limited to personal injury, loss of life, loss of product, production time, equipment, property damage, lost profits, consequential damages of any kind and environment damage and/or cleanup. Use of metric fasteners with ASME Class 150/300 bolt holes and flange bolt patterns is a misuse that voids all warranties and contractual assurances. If you use metric fasteners with ASME Class 150/300 bolt holes and flange bolt patterns, you do so at your sole risk and any liability associated with such use shall not be the responsibility of DeZURIK, Inc. In addition to the foregoing, DeZURIK's Manufacturer's Conditions apply.

Recommendations

Refer to the valve installation drawing for dimensional information.

- Installing the valve in the wrong location may cause excessive dynamic torque and damage the valve. It is recommended to install the valve at least 8 diameters from the nearest upstream elbow or pump. For best performance results, install valve shaft parallel with elbow or pump cross section (see image below). For more specific installation recommendations, contact your local representative or DeZURIK for assistance.

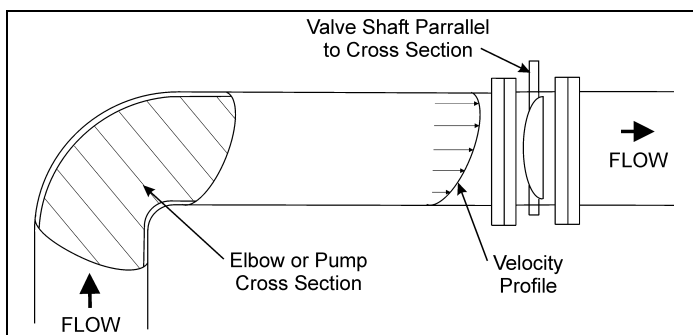

24" and Larger BHP High Performance Butterfly Valves With (FB) Fyre-Block® Seat

Installing Valve (continued)

- Valves with undrilled seat retainers are not suitable for dead-end service without a downstream flange.
- If possible, install the valve with the shaft horizontal to provide a self-cleaning action on the seat.

Install the valve so that the side opposite the seat will be on the higher pressure side when the valve is closed. The seat side of the valve is marked "SEAT". Pipeline flow may be in either direction through the valve.

Use self-centering flat ring flange gaskets.

- For 24" (600mm) Class 150 and Class 300 valves, use mating flanges that comply with the same class of ASME/ANSI B16.5.
- For larger sizes, use flanges that comply with the Class 150, Series A requirements of ASME B16.47.



CAUTION!

Lifting the valve incorrectly can damage it. Do not fasten lifting devices to the actuator or disc, or through the seat opening in the body. Lift the valve with slings fastened around the valve body or attach them to bolts or rods run through holes for the pipeline flanges.

1. If the valve does not have an actuator, mount the actuator on the valve. Refer as necessary to the actuator instructions and drawings.
2. Remove all foreign material such as weld spatter, oil, grease and dirt from the valve, flanges and pipeline.
3. Open the valve and clean the seat and the sealing edge of the disc.
4. Place the valve in the pipeline with the valve closed — handle the valve carefully so that the flange gasket sealing surfaces do not get damaged.

Note: Valves with (FB) Fyre-Block® seat option must be installed with higher pressure on the **side opposite the seat side**.

5. Ensure that the valve, the pipeline and the mating connections are aligned and centered before tightening the pipeline bolts.
6. Tighten the bolts evenly, in a crisscross pattern.

Operation

Clockwise rotation of the valve shaft closes the disc into the seat. A line on the top of the valve shaft indicates the position of the disc when the disc is not visible.

The valve is fully closed when the flat side of the disc is parallel with the flange sealing surface on the body. The valve is fully open when the disc is 90° counterclockwise from the closed position.

Note: The closed disc must not touch the stop lug in the body.

The actuator is connected to the valve shaft and positions the disc at the open, closed or intermediate positions. The position stops in the actuator are set to match the open and closed positions of the valve.

Note: Refer to the actuator instructions for stop adjustment information.

Required Tools

The valve is assembled using only SAE fasteners. To service this unit, you should have a full set of combination wrenches, Allen wrenches, a flat tipped screwdriver, a pin punch and a dead blow hammer.

Lubrication

The valve is lubricated at the factory and does not require routine lubrication. Refer to the actuator instructions for actuator lubrication requirements.

Adjusting Packing

The shaft seal consists of packing that is contained and compressed by the packing gland (A12).

1. If the packing leaks, tighten the two adjustment nuts (A15) on top of the packing gland (A12).

Note: Tighten the nuts evenly and gently—just enough to stop the leak. Over tightening will cause excessive torque and decrease packing life.

2. If the leak cannot be stopped by tightening the packing, replace the packing. See "Replacing Packing" section.

24" and Larger BHP High Performance Butterfly Valves
With (FB) Fyre-Block® Seat

Drawings

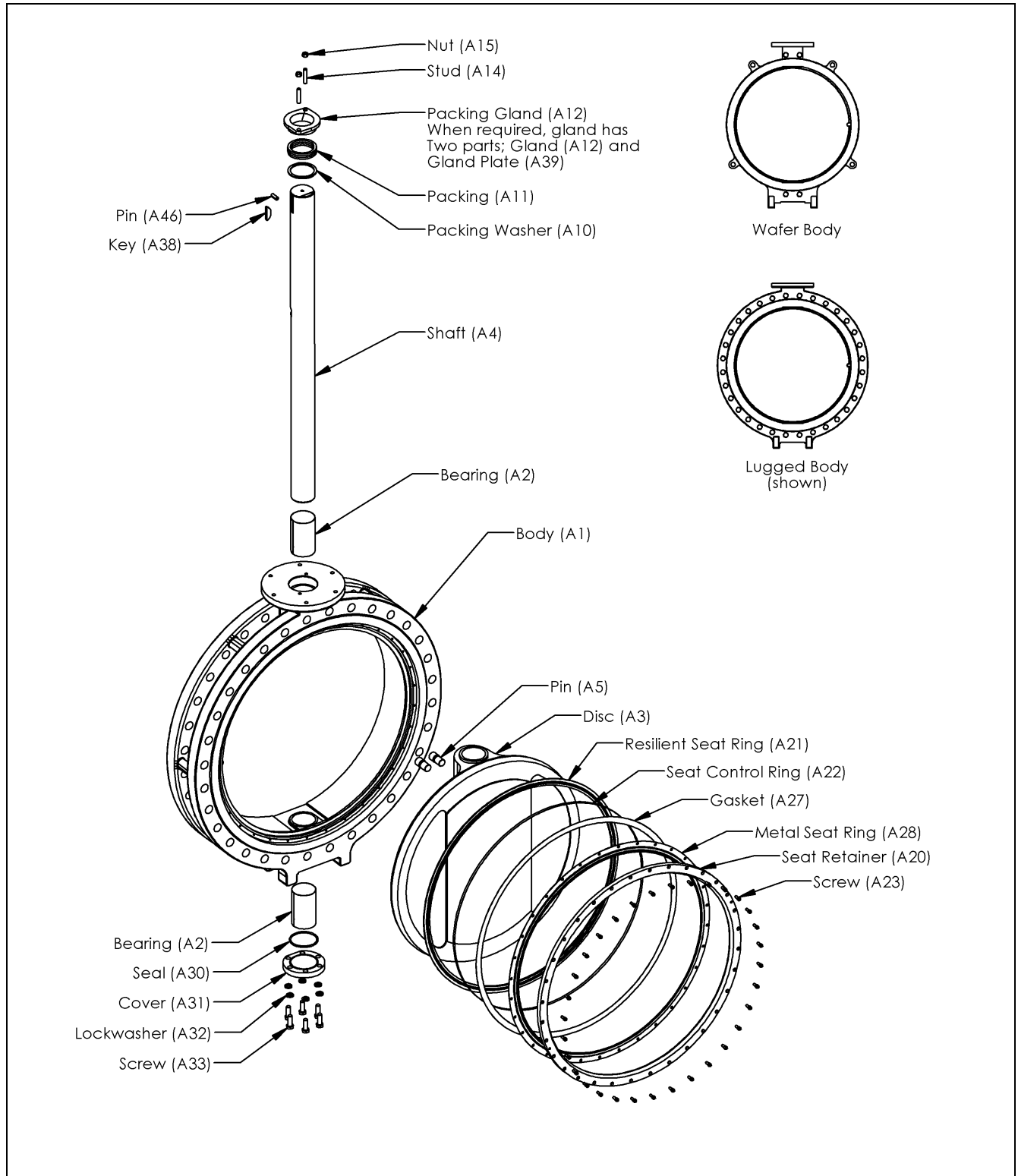

Figure 1 – Component Identification

Replacing Packing

The G1 packing is the only packing option available with the (FB) Fyre-Block seat. See Figure 2 for parts identification.

**WARNING!**

Pipeline pressure can cause personal injury or equipment damage. Relieve the pressure in the pipeline before removing the packing gland.

1. Discontinue flow and relieve pipeline pressure.

**WARNING!**

Accidental operation of powered actuator can cause personal injury or equipment damage. Disconnect and lock out power to actuator before servicing.

2. If the actuator is powered, disconnect and lock out the power to the actuator.
3. Remove the actuator as described in the actuator instructions and remove the actuator bracket from the valve.
4. Remove pin (A46) from valve shaft (A4) (does not apply to valves with stepped shafts).
5. Remove the two gland nuts (A15) and remove the gland (A12).
6. Remove all of the packing (A11).
7. Remove any packing fragments and ensure that all packing chamber sealing surfaces are clean.
8. Follow the procedure for the applicable packing option:

Carbon Graphite Packing Option (G1)

The new packing (A11) consists of one Graphoil ring and two carbon rings.

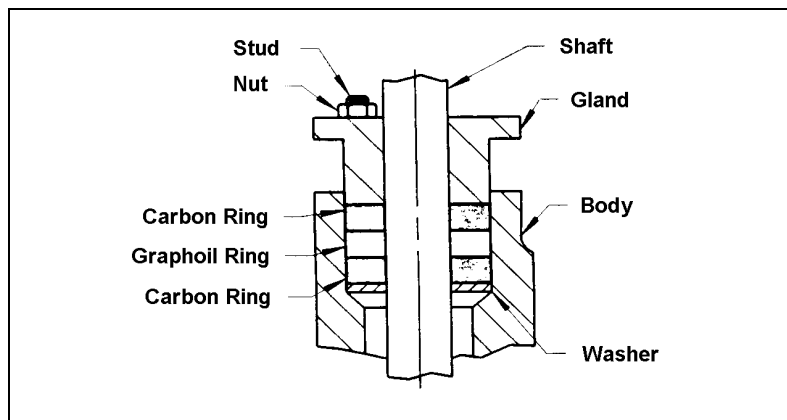

Figure 2 — Packing Option (G1)

- a. Place the packing in the body, one ring at a time, in the configuration shown in Figure 2 — do not lubricate.
- b. Replace the gland (A12) and the two gland nuts (A15).
- c. Tighten the nuts finger tight, plus ½ turn.
- d. Continue with Step 9 on Page 9.

24" and Larger BHP High Performance Butterfly Valves**With (FB) Fyre-Block® Seat****Replacing Packing** *(Continued)*

9. Replace pin (A46) in valve shaft (A4) (does not apply to valves with stepped shafts).
10. Re-mount the actuator bracket on the valve and tighten the screws as shown in Table A.
11. Mount the actuator on the valve—see actuator instructions.
12. If the actuator is a powered actuator, reconnect power to the actuator.
13. Actuate the valve. If necessary, adjust the position stops—see actuator instructions.
14. Pressurize the valve.
15. If the packing leaks, tighten the gland nuts evenly and slowly, just enough to stop the leak.

Torque Specification**Table A: Fastener Torques, Actuator Bracket-to-Valve**

Valve			Fastener (Grade 5 Ref)		
Class	Size		Size (Ref)	Torque	
	in	mm		ft lbs	Nm
150	24–36	600–900	5/8-11	180±20	244±27
	42 and 48	1050–1200	3/4-10	330±40	447±54
300	24	600	5/8-11	180±20	244±27
	30 & 36	750 & 900	3/4-10	330±40	447±54
	54	1350	3/4-10	330±40	447±54

Seat Replacement

Removing Valve From Pipeline



WARNING!

Pipeline pressure can cause personal injury or equipment damage. Relieve the pressure in the pipeline before removing flange bolts and flanges.

1. Relieve pressure in the pipeline and drain the pipeline.
 2. Close the valve.
-



WARNING!

Accidental operation of powered actuator can cause personal injury or equipment damage. Disconnect and lock out power to actuator before servicing.

3. If the actuator is powered, disconnect and lock out the power to the actuator.
4. Support the valve, remove the flange bolts and remove the valve from the pipeline.
Note: Lifting the valve incorrectly can damage it. Do not fasten lifting devices to the actuator or disc, or through the seat opening in the body. Lift the valve with slings fastened around the valve body, or attach them to bolts or rods run through holes for the pipeline flanges.

Replacing the Seat

1. Place the valve in a horizontal position, with the seat side up.
2. Refer to Figure 1 (page 6) for component identification.
3. Remove the seat retainer screws (A23), the seat retainer (A20) and all of the seat components.
Note: The seat retainer has two tapped holes. Screws may be threaded into these holes to remove the seat retainer.
4. Clean the seat cavity in the body and the seat cavity in the seat retainer.
5. Close the valve.
6. Refer to the Fyre-Block® seat option:
 - Seat Options (TTS2 and RTS2) — see Figure 3 on Page 10

24" and Larger BHP High Performance Butterfly Valves**With (FB) Fyre-Block® Seat****Seat Replacement (Continued)****Fyre-Block® Seat Options (TTS2 and RTS2)**

- a. If the actuator is connected to the valve shaft, loosen the connection so that the valve shaft can rotate.
- b. Loosen the packing gland nuts (A15).
- c. Place the seat control ring (A22) in the groove in the new PTFE seat (A21).
- d. Center the PTFE seat (A21), the gasket (A27) and the metal seat (A28) on the closed disc.
- e. Apply a rust inhibitor such as Never Seez to the threads of the seat retainer screws (A23).
- f. With all components centered, mount the seat retainer (A20) to the body with the seat retainer screws. Tighten the screws as shown in Table B.
- g. If the valve actuator connection was loosened in step a, tighten the connection.
- h. Adjust the packing gland nuts (A15) as described in the *Packing Adjustment* section.
- i. Continue with step 7.

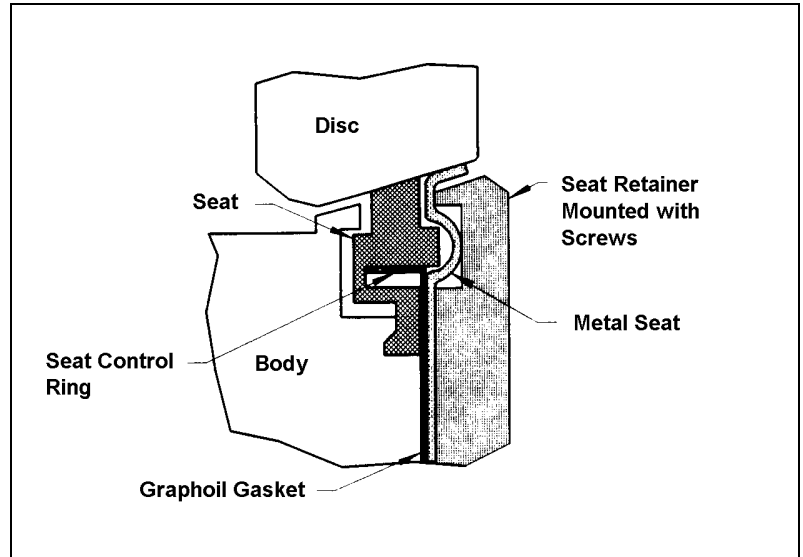

**Figure 3 — Seat Options
(TTS2 and RTS2)**

Table B: Seat Retainer Screw Torques

Screw Size	Torque	
	ft lbs	Nm
8-32	1.5 ± 0.5	2.03 ± 0.69
10-24	2.5 ± 0.5	3.39 ± 0.69
1/4-20	5.5 ± 1.5	7.46 ± 2.03
5/16-18	12.0 ± 3.0	16.27 ± 4.07
3/8-16	21.5 ± 5.5	29.15 ± 7.46
1/2-13	45.0 ± 7.0	61.01 ± 9.49

7. Install the valve in the pipeline as described in the Installation section.
8. If the actuator is a powered actuator, reconnect the power to the actuator.
9. Pressurize the valve.
10. If packing leaks, tighten the gland nuts evenly and slowly – just enough to stop the leakage.

Valve Disassembly

Refer to Figure 1 (page 6) for component identification.



WARNING!

Pipeline pressure can cause personal injury or equipment damage. Relieve the pressure in the pipeline before removing flange bolts and flanges.

1. Relieve the pressure in the pipeline, drain the pipeline and close the valve.
-



WARNING!

Accidental operation of powered actuator can cause personal injury or equipment damage. Disconnect and lock out power to actuator before servicing.

2. If the actuator is powered, disconnect and lock out the power to the actuator.
3. Support the valve, remove the flange bolts and remove the valve from the pipeline.
Note: Lifting the valve incorrectly can damage it. Do not fasten lifting devices to the actuator or disc, or through the seat opening in the body. Lift the valve with slings fastened around the valve body, or attach them to bolts or rods run through holes for the pipeline flanges.
4. Remove the actuator and the actuator bracket from the valve.
5. Remove pin (A46) from valve shaft (A4) (does not apply to valves with stepped shafts).
6. Remove the two gland nuts (A15) and remove the gland (A12).
7. Remove all of the packing (A11).
8. Remove all packing fragments, dirt and other contaminants from all packing sealing surfaces.
9. Remove the seat retainer screws (A23), the seat retainer (A20) and all of the seat components.
Note: The seat retainer on all valve sizes have two tapped holes. Screws may be threaded into these holes to remove the seat retainer.
10. Remove the cover screws (A33), lockwashers (A32), cover (A31) and seal (A30) from the bottom of the body.
11. Remove the two disc pins (A5) — see Figure 4 on Page 13
12. Place the valve in a horizontal position with the seat side down.
13. While supporting the disc (A3), carefully pull the shaft (A4) from the body and remove the disc.

Bearing Replacement

Nickel Stainless Bearings (Option NS)

The Nickel Stainless bearing option consists of two one-piece bearings (A2) pressed into the body.

1. Drive the used bearings out of the body.
2. Press the new bearings into position in the body.

24" and Larger BHP High Performance Butterfly Valves With (FB) Fyre-Block® Seat

Valve Reassembly

1. With the valve horizontal and the seat side down, align the shaft hole in the disc (A3) with the assembled bearing components in the body.
2. Then insert the bottom end of the shaft (the end without an actuator connection) into the top of the body and push the shaft into position.
3. Rotate the shaft so that the line on the top end of the shaft is towards and parallel with the flat (or concave) side of the disc.
 - a. Slide the shaft so that the disc pin slots in the shaft are aligned with the disc pin holes in the disc.
 - b. Apply a rust inhibitor such as Never Seez to the threads of the disc pins (A5).
 - c. Use two new pins and turn the pins into the threaded holes in the disc (A3) and against the slots in the shaft (A4) as shown in Figure 4 on page 13.
 - d. Adjust the pins so that both pins protrude the same distance above the disc surface and tighten the pins as shown in Table C on Page 12.
 - e. As shown in Figure 4 on Page 13, stake the screw threads on each disc pin once with a pointed punch to secure the pins in position.
4. Replace the seat and the seat retainer as described in steps 4, 5 and 6 in the *Seat Replacement* section on page 9.
5. Replace pin (A46) in valve shaft (A) (does not apply to valves with stepped shafts).
6. Replace the packing, the packing gland and the gland adjustment nuts as shown in steps 7 and 8 of the *Replacing Packing* section on page 7.
7. Mount the cover (A31) and seal (A30) to the bottom of the body with the lockwashers (A32) and cover screws (A33).
8. Lubricate the threads of the screw with a rust inhibitor such as Never Seez.
9. Tighten the screws as follows: 1/2-13 screws to 38±5 ft lbs. (52±6 Nm), 5/8-11 screws to 77±10 ft lbs. (104±14 Nm) and 3/4-10 screws to 140±18 ft lbs. (190±24 Nm).
10. Mount the actuator bracket on the valve and tighten the screws as shown in Table A on Page 8.
11. Re-mount the actuator on the valve (see actuator instructions).
12. Actuate the valve. If necessary, adjust the actuator position stops.
13. Install the valve in the pipeline as described in the *Installing Valve* section.
14. If the actuator is a powered actuator, reconnect the power to the actuator.
15. Pressurize the valve.
16. If packing leaks, tighten the gland nuts evenly and slowly – just enough to stop the leak.

Table C: Disc Pin Torques

Fastener Type	Fastener Size	Torque	
		ft lbs.	Nm
24 – 54" (600-1350mm) Disc Pin (A5)	3/4-10	115 ± 15	160 ± 20
	7/8-9	180 ± 23	245 ± 30
	1-8	270 ± 35	370 ± 50
	1 1/8-7	380 ± 50	520 ± 70
	1 1/4-7	540 ± 70	730 ± 95
	1 3/4-5	1600 ± 200	2200 ± 300
	2-8	2100 ± 300	2900 ± 400
	2 1/4-8	3000 ± 400	4100 ± 550

Valve Reassembly *(Continued)*

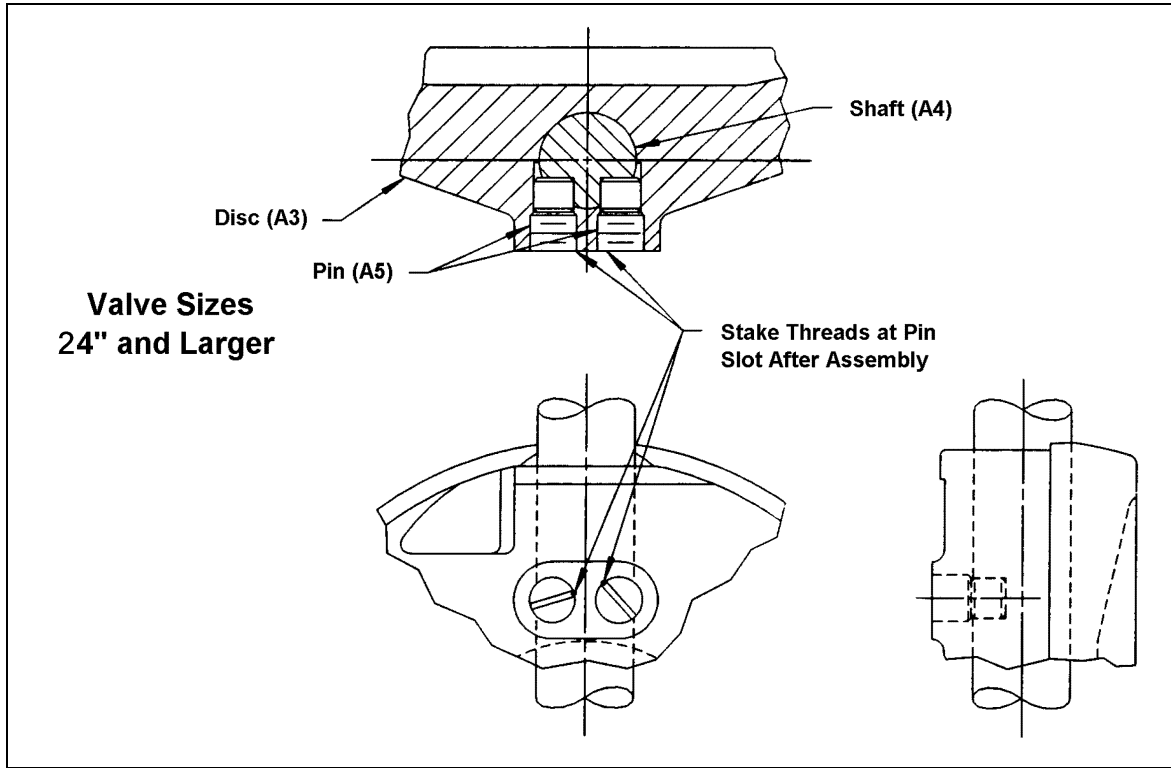

Figure 4 – Disc Pin Assembly

24" and Larger BHP High Performance Butterfly Valves With (FB) Fyre-Block® Seat

Troubleshooting

Condition	Possible Cause	Corrective Action
Packing Leaks	Packing is loose.	Adjust packing.
	Packing is worn.	Replace packing.
Valve leaks when closed.	Closed position stop is set incorrectly.	Adjust closed stop.
	Seat is worn or damaged.	Replace seat.
	Sealing edge of disc is worn or damaged.	Replace disc.
Valve body leaks from seat retainer area.	Pipeline flange bolting is loose.	Tighten pipeline flange bolts.
	Pipeline flanges are misaligned.	Align pipeline flanges.
	Pipeline flange gasket or seat retainer gasket is worn.	Replace gasket(s).
Valve does not fully close.	Object is wedged between disc and seat.	Open valve and allow flushing action to remove object.
	Closed position stop is not adjusted correctly.	Adjust closed stop.
	Disc-to-shaft connection has failed.	Replace disc pins and/or shaft.
Valve does not fully open.	Open position stop is not adjusted correctly.	Adjust open stop.
	Disc-to-shaft connection has failed.	Replace disc pins and/or shaft.
Opening or closing torque is excessive.	Bearings, shaft, disc and/or seat are dirty or worn.	Clean or replace dirty or worn components.
	Shaft is bent.	Replace shaft.
Seat leakage and/or damage to seat has occurred.	Media is abrasive.	Replace existing seat with a seat that is suitable for abrasive media.
Valve components are eroding.		Replace valve with materials suitable for abrasive media.
Valve leakage and/or damage to valve has occurred.	Valve encountered higher than rated pressure.	Reduce media pressure.
Seat leakage and/or damage to seat has occurred.	Valve encountered higher than rated temperature.	Reduce media temperature.
		Replace existing seat with a seat suitable for the required temperature.
Valve components are corroding.	Media is corrosive and incompatible with valve material.	Replace existing valve with a valve constructed of material compatible with the media.

Guarantee

Products, auxiliaries and parts thereof of DeZURIK, Inc. manufacture are warranted to the original purchaser for a period of twenty-four (24) months from date of shipment from factory, against defective workmanship and material, but only if properly installed, operated and serviced in accordance with DeZURIK, Inc. recommendations. Repair or replacement, at our option, for items of DeZURIK, Inc. manufacture will be made free of charge, (FOB) our facility with removal, transportation and installation at your cost, if proved to be defective within such time, and this is your sole remedy with respect to such products. Equipment or parts manufactured by others but furnished by DeZURIK, Inc. will be repaired or replaced, but only to the extent provided in and honored by the original manufacturers warranty to DeZURIK, Inc., in each case subject to the limitations contained therein. No claim for transportation, labor or special or consequential damages or any other loss, cost or damage shall be allowed. You shall be solely responsible for determining suitability for use and in no event shall DeZURIK, Inc. be liable in this respect. DeZURIK, Inc. does not guarantee resistance to corrosion, erosion, abrasion or other sources of failure, nor does DeZURIK, Inc. guarantee a minimum length of service. Your failure to give written notice to us of any alleged defect under this warranty within twenty (20) days of its discovery, or attempts by someone other than DeZURIK, Inc. or its authorized representatives to remedy the alleged defects therein, or failure to return product or parts for repair or replacement as herein provided, or failure to install and operate said products and parts according to instructions furnished by DeZURIK, Inc., or misuse, modification, abuse or alteration of such product, accident, fire, flood or other Act of God, or failure to pay entire contract price when due shall be a waiver by you of all rights under this warranty.

The foregoing guarantee shall be null and void if, after shipment from our factory, the item is modified in any way or a component of another manufacturer, such as but not limited to, an actuator is attached to the item by anyone other than DeZURIK, Inc. Factory Service personnel. All orders accepted shall be deemed accepted subject to this limited warranty, which shall be exclusive of any other or previous Warranty, and this shall be the only effective guarantee or warranty binding on DeZURIK, Inc., despite anything to the contrary contained in the purchase order or represented by any agent or employee of DeZURIK, Inc., in writing or otherwise, notwithstanding, including but not limited to implied warranties.

Metric fasteners should not be used with ASME Class 150/300 bolt holes and flange bolt patterns. If you use metric fasteners with ASME Class 150/300 bolt holes and flange bolt patterns, it may lead to product failure, injury, and loss of life. DeZURIK Inc. disclaims all liability associated with the use of metric fasteners with ASME Class 150/300 bolt holes and flange patterns, including but not limited to personal injury, loss of life, loss of product, production time, equipment, property damage, lost profits, consequential damages of any kind and environment damage and/or cleanup. Use of metric fasteners with ASME Class 150/300 bolt holes and flange bolt patterns is a misuse that voids all warranties and contractual assurances. If you use metric fasteners with ASME Class 150/300 bolt holes and flange bolt patterns, you do so at your sole risk and any liability associated with such use shall not be the responsibility of DeZURIK, Inc. In addition to the foregoing, DeZURIK's Manufacturer's Conditions apply.

THE FOREGOING REPAIR AND REPLACEMENT OBLIGATIONS ARE IN LIEU OF ALL OTHER WARRANTIES, OBLIGATIONS AND LIABILITIES, INCLUDING ALL WARRANTIES OF FITNESS FOR A PARTICULAR PURPOSE OR OF MERCHANTABILITY OR OTHERWISE, EXPRESSED OR IMPLIED IN FACT OR BY LAW, AND STATE DEZURIK, INC.'S ENTIRE AND EXCLUSIVE LIABILITY AND YOUR EXCLUSIVE REMEDY FOR ANY CLAIM IN CONNECTION WITH THE SALE AND FURNISHING OF SERVICES, GOODS OR PARTS, THEIR DESIGN, SUITABILITY FOR USE, INSTALLATION OR OPERATIONS.

Limitation of liability

LIMITATION OF LIABILITY: IN NO EVENT SHALL DEZURIK, INC. BE LIABLE FOR ANY DIRECT, INDIRECT, SPECIAL OR CONSEQUENTIAL DAMAGES WHATSOEVER, AND DEZURIK, INC.'S LIABILITY, UNDER NO CIRCUMSTANCES, WILL EXCEED THE CONTRACT PRICE FOR THE GOODS AND/OR SERVICES FOR WHICH LIABILITY IS CLAIMED. ANY ACTION BY YOU FOR BREACH OF CONTRACT MUST BE COMMENCED WITHIN 12 MONTHS AFTER THE DATE OF SALE.

Sales and Service

For information about our worldwide locations, approvals, certifications and local representative:

Web site: www.dezurik.com E-Mail: info@dezurik.com



250 Riverside Ave. N., Sartell, MN 56377 • Phone: 320-259-2000 • Fax: 320-259-2227

DeZURIK, Inc. reserves the right to incorporate our latest design and material changes without notice or obligation. Design features, materials of construction and dimensional data, as described in this manual, are provided for your information only and should not be relied upon unless confirmed in writing by DeZURIK, Inc. Certified drawings are available upon request.