



APCO AVV-140/150 AND 1100 AIR/VACUUM VALVES



Series 140
.5" (15 mm) - 3" (80 mm)



Series 150
4" (100 mm) - 30" (750 mm)

Instruction **D12014**
June 2014

DeZURIK

APCO AVV-140/150 and 1100 Air/Vacuum Valves

Instructions

These instructions provide installation, operation and maintenance information for APCO AVV-140/150 and 1100 Air/Vacuum Valves. They are for use by personnel who are responsible for installation, operation and maintenance of APCO AVV-140/150 and 1100 Air/Vacuum Valves.

Safety Messages

All safety messages in the instructions are flagged with an exclamation symbol and the word Caution, Warning or Danger. These messages indicate procedures that must be followed exactly to avoid equipment damage, personal injury or death. Safety label(s) on the product indicate hazards that can cause equipment damage, personal injury or death.

Safety label(s) on the product indicate hazards that can cause equipment damage, personal injury or death. If a safety label becomes difficult to see or read, or if a label has been removed, please contact DeZURIK for replacement label(s).



WARNING!

Personnel involved in the installation or maintenance of valves should be constantly alert to potential emission of pipeline material and take appropriate safety precautions. Always wear suitable protection when dealing with hazardous pipeline materials. Handle valves, which have been removed from service with suitable protection for any potential pipeline material in the valve.

Inspection

Your APCO AVV Air/Vacuum Valve has been packaged to provide protection during shipment; however, it can be damaged in transport. Carefully inspect the unit for damage upon arrival and file a claim with the carrier if damage is apparent.

Parts

Recommended spare parts are listed on the assembly drawing. These parts should be stocked to minimize downtime. Order parts from your local DeZURIK sales representative, or directly from DeZURIK. When ordering parts please choose from the following:

If the valve has a DeZURIK APCO nameplate please include the 7-digit part number and 4-digit revision number (example: 9999999R000) located on the data plate attached to the valve assembly. Also include the part name, the assembly drawing number, the balloon number and the quantity stated on the assembly drawing.

If there isn't any nameplate visible on the valve, please include Valve Model number, the part name, and item number from the assembly drawing. You may contact your local DeZURIK APCO Representative to help you identify your valve.

DeZURIK Service

DeZURIK service personnel are available to maintain and repair all DeZURIK products. DeZURIK also offers customized training programs and consultation services.

For more information, contact your local DeZURIK sales representative or visit our website at www.dezurik.com.

Table of Contents

Description ----- 4

Handling and Storage ----- 4

Installation ----- 4

Fusion/Powder Coated Valves ----- 4

Maintenance ----- 5

Disassembly Procedure (AVV-140 and 140H)----- 5

Assembly Procedure (AVV-140 and 140H)----- 6

Disassembly Procedure (AVV-150 and 1100)----- 6

Assembly Procedure (AVV-150 and 1100)----- 8

Operation ----- 8

Drawings ----- 9

Troubleshooting ----- 13



This Drinking Water System Component is tested and certified by WQA against NSF/ANSI Standard 61.

DeZURIK

APCO AVV-140/150 and 1100 Air/Vacuum Valves

Description

An Air/Vacuum Valve consists of a body, cover, baffle, float and seat. It has a large venting orifice and is used to exhaust large quantities of air from a pipeline when being filled or a deep well pump column when the pump is started. Once the line is filled, the Air/Vacuum Valve closes and remains closed until the liquid is drained and pressure returns to atmospheric. The Air/Vacuum Valve will then immediately open to allow air to re-enter the line and prevent a vacuum from developing.

Handling and Storage

Lifting the valve improperly may damage it. Do not fasten lifting devices to piping or attached components. Lift the valve with slings, chains or cables fastened around the valve body, or fastened to bolts or rods through bolt holes in the flanges.

If installation will be delayed, place valve indoors in secure, weather tight storage. If temporary outside storage is unavoidable, make sure a vermin proof rain cover (water shedding tarp, etc.) is secured around/over the valve to keep off rain and mud. Skid and set the assembly on a flat, solid, and well drained surface for protection from ground moisture, runoff and pooled rain water.

Installation

The Air/Vacuum Valve should always be installed in a vertical position. An isolation valve between this unit and the transmission (pipeline) system is recommended.

- Before installation, remove foreign material such as weld spatter, oil, grease, and dirt from the pipeline.
- Prepare pipe ends and install valves in accordance with the pipe manufacture's instructions for the joint used.



CAUTION!

Do not deflect the pipe-valve joint. Minimize bending stresses in the valve end connection with pipe loading.

- Tighten the flange bolts or studs in a crisscross pattern and minimum of four stages.

Fusion/Powder Coated Valves



CAUTION!

Valves with fusion/powder coated exterior paint require flat washers to be installed under the flange nuts when installing the valve to the pipeline flange to prevent the paint from cracking or chipping.

Maintenance

The Air/Vacuum Valve is automatic in operation and requires little or no maintenance. For precaution, it is recommended that a semi-annual visual inspection for leakage and cleaning of any environmental debris accumulated around the valve. A malfunction of the valve is evident by seepage of the media through the exhaust port. Should any malfunction occur, the following steps should be taken to repair the valve: **Warning: Do not work on the valve while under pressure.**

Disassembly Procedure (AVV- 140 and 140H)

See Figure 1 and Figure 2 for part identification.



WARNING!

Servicing the Air Valve while the pipeline is under pressure can cause personal injury or equipment damage. Relieve pipeline pressure or shut off isolation valve before servicing the Air Valve.

1. Relieve pipeline pressure or shut off isolation valve on inlet pipe.



WARNING!

Do not completely remove pipe plug or cover screws while the valve is under pressure.

2. Loosen pipe plug in cover (2) to relieve internal pressure. **Do not completely remove pipe plug while the valve is under pressure.**

For ½” Valves: Loosen the cover screws (4) to allow internal pressure to escape. **Do not completely remove cover screws while the valve is under pressure.**

3. Inspect exhaust port on top. If any foreign matter or dirt is preventing float (14) from seating properly against the seat (6), clean or replace as necessary. Buna-N seat hardness (Durometer) should correspond to the operating pressure as shown in Table A:

Table A: Buna-N seat hardness (Durometer)

Valve Size	Working Pressure, psi				
	0-10	11-50	51-100	101-200	201-300
½”	20	45	45	45	85
1”	45	65	65	65	85
2”	45	65	85	85	85
3”	45	65	85	85	85

4. Perform a seat test. Replace pipe plug or tighten cover screws (4) diagonally on size ½” and slowly fill valve chamber by cracking open isolation valve on inlet pipe. If seepage persists, repeat steps 1 and 2 and proceed as follows;
5. Remove cover screws (4) and cover (2) with all the internal components all-together from the valve body (1).

DeZURIK

APCO AVV-140/150 and 1100 Air/Vacuum Valves

Maintenance *(Continued)*

6. Remove seat retaining screws (34) and baffle (24) and lift out seat (6) from the recess in the cover (2) or baffle. For valves with water diffuser, it is necessary to remove the water diffuser by removing float bushing (26) for size 3" or baffle plug (41).
7. Remove cover gasket (3).
8. Clean all surfaces including perforation of the water diffuser. Replacement is recommended.
9. Inspect all components. Replace if necessary.

Assembly Procedure *(AVV-140 and 140H)*

1. Install float (14) and baffle plug (41) if included with float guide (33) to baffle (24).

For 3" valve size: Secure float (14) together with float guide (33) to the baffle (24) with float bushing (26).

2. Install seat (6) in place.
3. With cover (2) lying upside down on a level work bench, set the baffle assembly in place. Align and match screw holes through the baffle (24), seat (6), and cover (2), by inserting and turning baffle screw (34) with fingers.
4. Before tightening baffle screws (34) with an open (box) wrench, position baffle (24) by allowing float (14) to center perfectly in the seat (6), then tighten baffle screws opposite each other in rotation.
5. If water diffuser is required, remove baffle plug (41) with the float guide (33) and slip the water diffuser around the baffle (24). Then secure float (14) and water diffuser to baffle with baffle plug and float guide.

For 3" valve size: Remove float guide (33) and slip water diffuser around the baffle (24). Then secure float (14) and water diffuser in place with the float guide.

6. Install new cover gasket (3) and set cover (2) assembly to the body (1), then tighten cover screws (4) diagonally opposite each other in rotation.
7. Install and secure pipe plug and perform a seat test per Step 4 of Disassembly Procedure.
8. If there is no more leakage, fully open isolation valve on the inlet pipe.

Disassembly Procedure *(AVV-150 and 1100)*

See Figure 3 and Figure 4 for part identification.



WARNING!

Servicing the Air Valve while the pipeline is under pressure can cause personal injury or equipment damage. Relieve pipeline pressure or shut off isolation valve before servicing the Air Valve.

1. Relieve pipeline pressure or shut off isolation valve on inlet pipe.

Maintenance *(Continued)*



WARNING!

Do not completely remove pipe plug while the valve is under pressure.

2. Slowly remove pipe plug near inlet of valve body (1) to relieve internal pressure and to drain the unit.
3. Check to see if foreign matter or dirt is preventing float (14) from seating properly against seat. Clean as necessary.
4. Perform a seat test. Replace pipe plug and slowly fill valve chamber by cracking open isolation valve on inlet pipe. If seepage persists, repeat Steps 1 and 2 and proceed as follows:
5. Remove cover screws (4) and cover (2).
6. Remove seat screws (16) and lift out seat (6) from recess in cover (2).
7. Inspect seat (6) and float (14) seating surfaces for damage. Replace if necessary.
8. Inspect all other parts of valve such as guide bushings (26 & 43) and bumper (40).

Assembly Procedure (AVV-150 and 1100)

1. Clean surface of recess in cover (2) and install seat (6) with seat screws (16). Buna-N seat hardness (Durometer) should correspond to operating pressure as shown:

Table B: Buna-N seat hardness (Durometer)

Valve Size	Working Pressure, psi				
	0-10	11-50	51-100	101-200	201-300
4"	45	65	85	85	Metal
6"	65	85	85	85	Metal
8"	65	85	85	85	Metal
10"	65	85	85	85	Metal
12"	65	85	85	85	Metal
14"	Metal	Metal	Metal	Metal	Metal
16"	Metal	Metal	Metal	Metal	Metal
18"	Metal	Metal	Metal	Metal	Metal
20"	Metal	Metal	Metal	Metal	Metal
24"	Metal	Metal	Metal	Metal	Metal

Note: *Stainless Steel metal seats have Buna-N molded ring.*

DeZURIK

APCO AVV-140/150 and 1100 Air/Vacuum Valves

Maintenance *(Continued)*

2. Install bumper (40) and float (14) in place.
3. Assemble cover (2) and gasket (3) to body (1). Tighten cover screws (4) opposite each other in rotation.
4. Install and secure pipe plug and perform a seat test per Step 4 of Disassembly Procedure.
5. If there is no more leakage, fully open isolation valve on the inlet pipe.

Operation

The Air/Vacuum Valve is automatic in operation. It has a large venting orifice and will exhaust large quantities of air from a pipeline when being filled or a deep well column when the pump is started. Once the line is filled, the Air/Vacuum Valve closes and remains closed until the liquid is drained and pressure returns to atmospheric. The Air/Vacuum Valve will then immediately open and admit large volumes of air into the line and prevent vacuum from developing.

Drawings

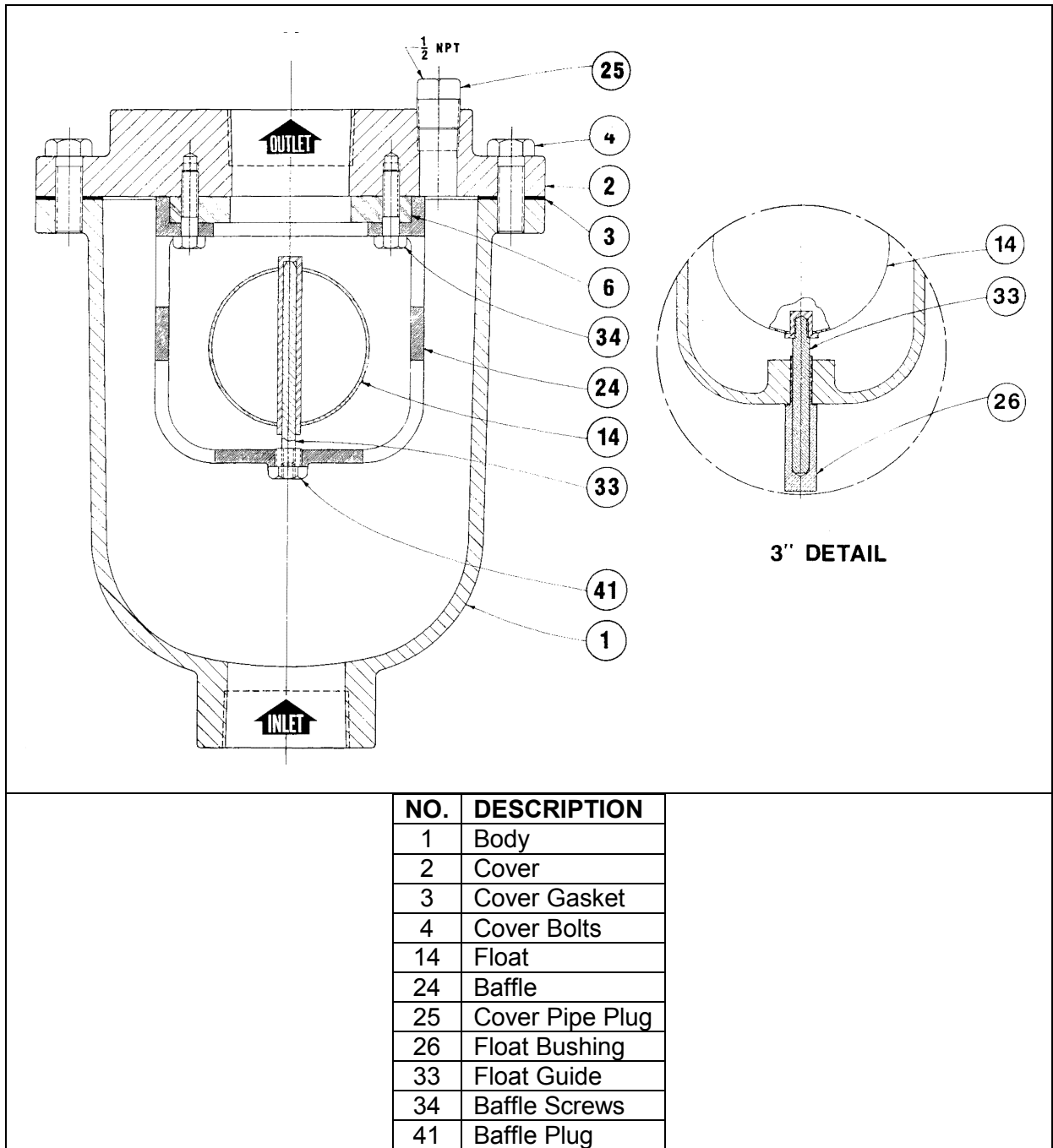
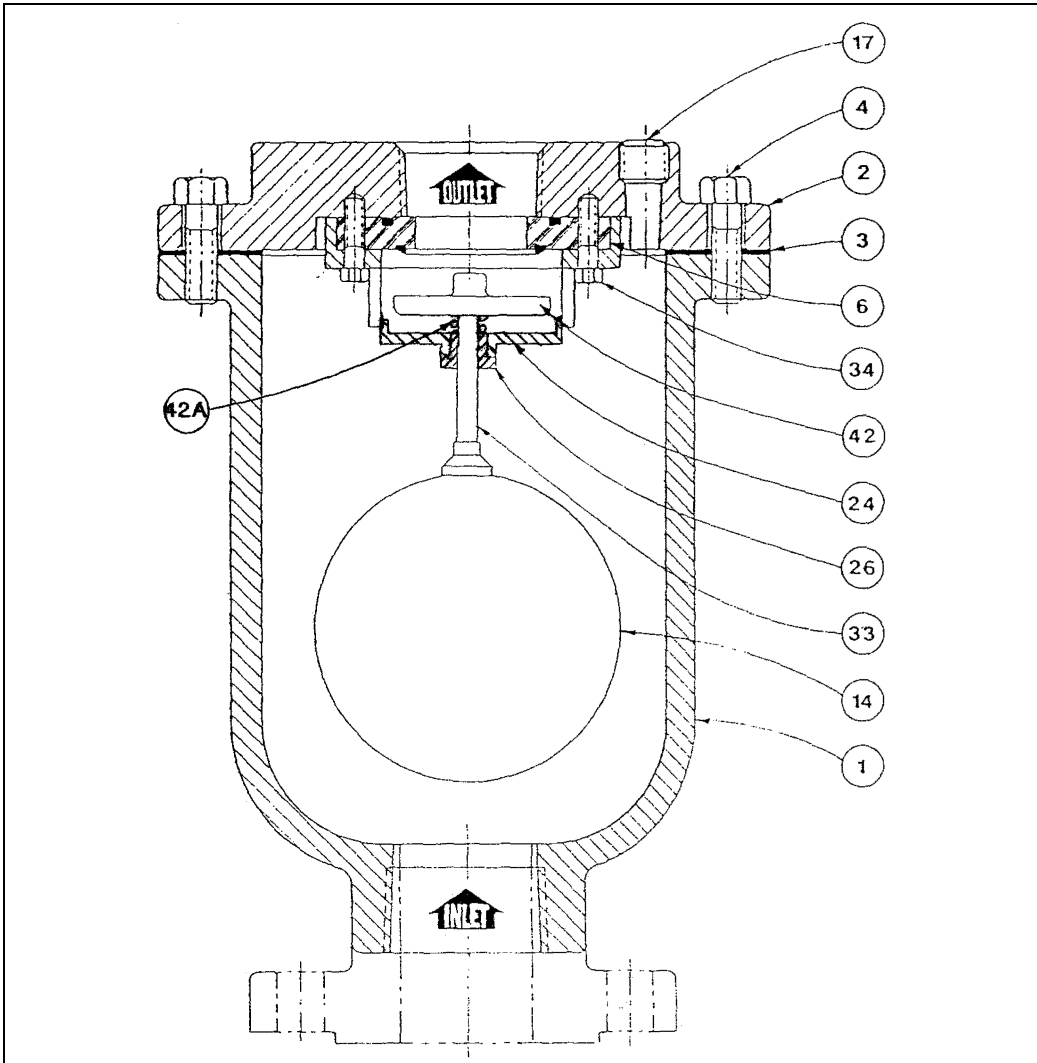

Figure 1: AVV-140 Air/Vacuum Valve

DeZURIK

APCO AVV-140/150 and 1100 Air/Vacuum Valves

Drawings (Continued)



NO.	DESCRIPTION
1	Body
2	Cover
3	Cover Gasket
4	Cover Bolt
6	Seat
14	Float
17	Pipe Plug
24	Baffle
26	Stem Guide
33	Float Stem
34	Baffle Retaining Screw
42	Seat Plug
42A	Spring

Figure 2: AVV-140H Air/Vacuum Valve for High Pressure Pipeline Service

Drawings (Continued)

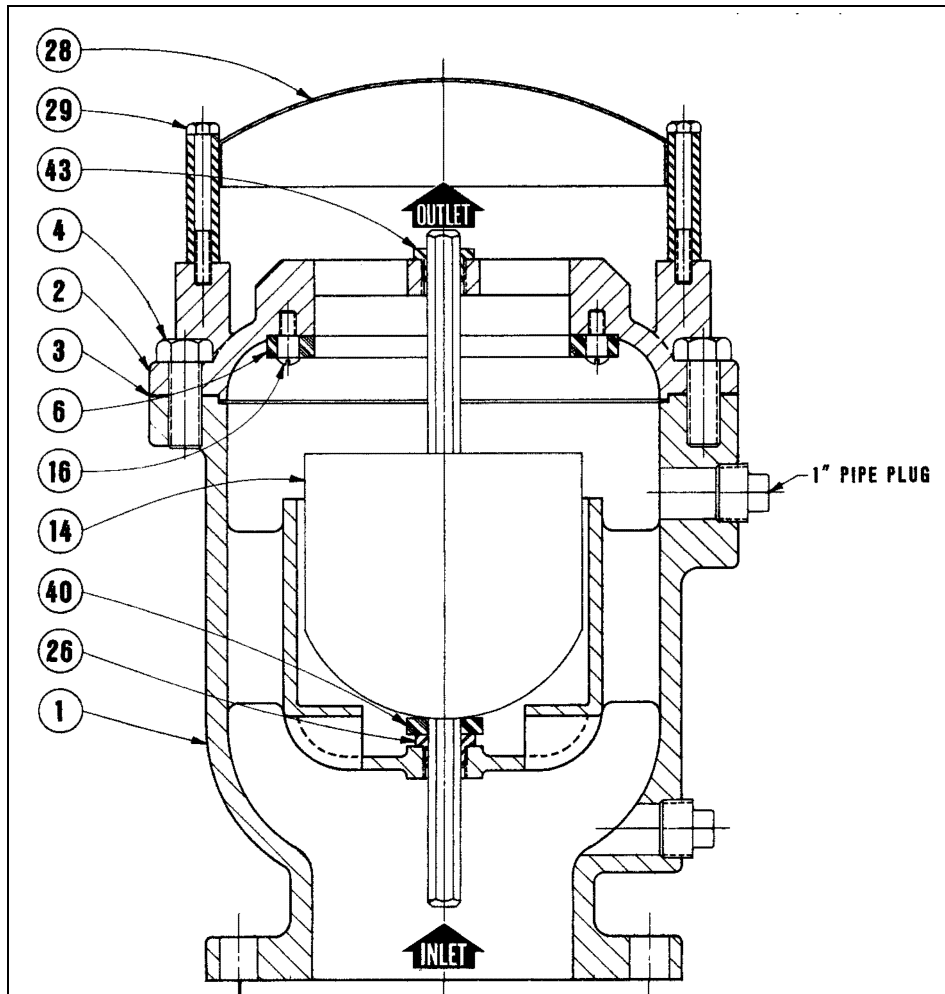

NO.	DESCRIPTION
1	Body
2	Cover
3	Cover Gasket
4	Cover Bolts
5	Leverage Frame
6	Seat
14	Float
16	Seat Screw
26	Float Guide Bushing
28	Hood
29	Hood Screw
40	Bumper
42	Plug
43	Float Guide Bushing

Figure 3: AVV-150 Air/Vacuum Valve

DeZURIK

APCO AVV-140/150 and 1100 Air/Vacuum Valves

Drawings (Continued)

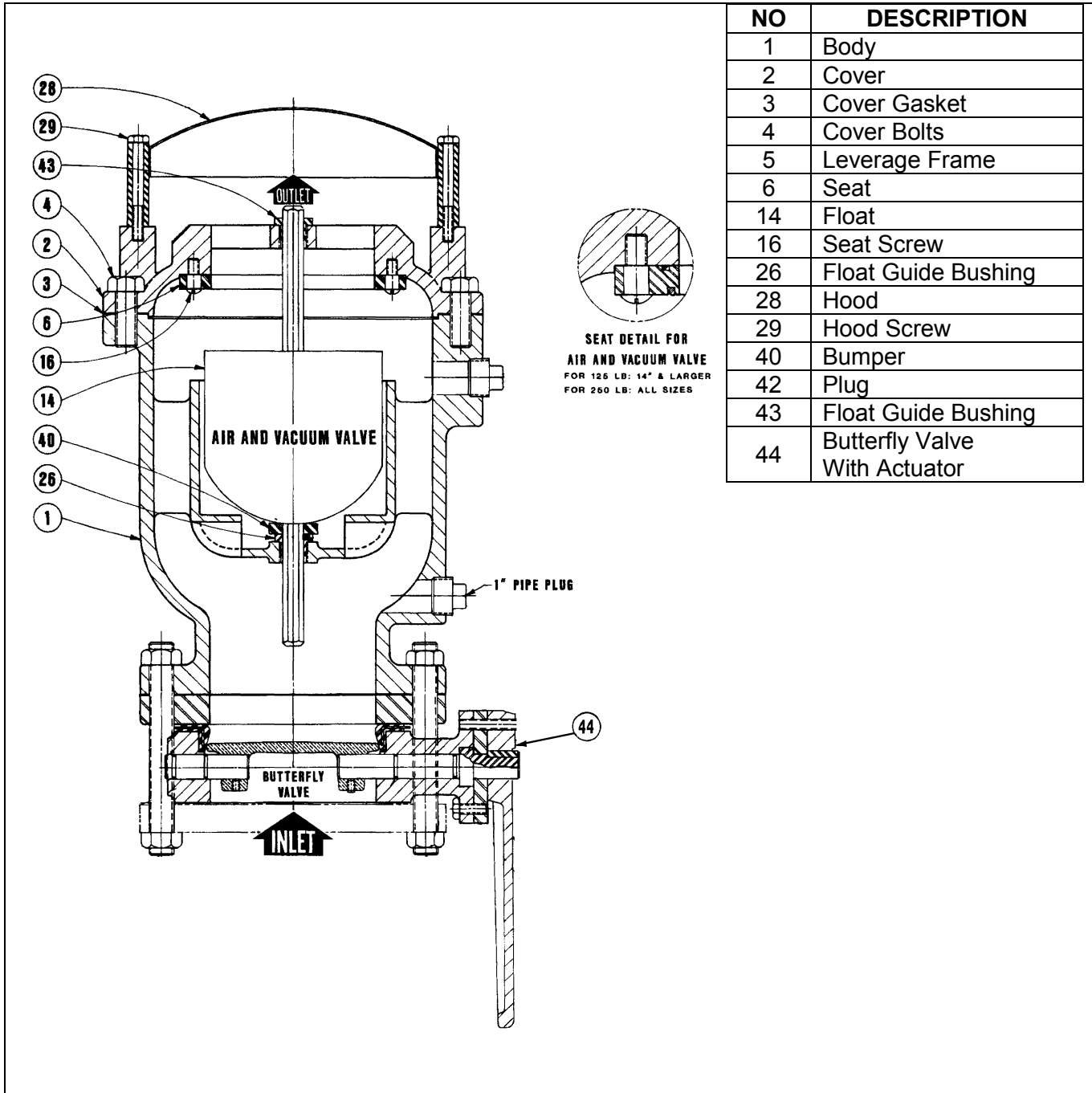

Figure 4: AVV-1100 Air/Vacuum Valve with Isolation Butterfly Valve

Troubleshooting

Condition	Possible Cause	Corrective Action
Valve leaks at flange joint.	Loose flange bolting.	Tighten flange bolting.
	Blown flange gasket.	Replace flange gasket.
	Miss-alignment or damage to field piping and supports.	Adjust miss-alignment or repair piping or supports.
	Damaged flange face/s or improper flange connections.	Repair flange, replace valve body or adjust flange connections.
Valve leaks out of Outlet port.	Dirty seat and/or float (seat plug in 140H).	Clean seat and/or float (seat plug in 140H).
	Worn seat and/or float (seat plug in 140H).	Replace seat and/or float (seat plug in 140H).
	Line pressure is under 10 psi.	Replace seat with softer seat.
	Float linkage is dirty.	Clean float linkage.
	Float has liquid in it.	Replace float.

Guarantee

Products, auxiliaries and parts thereof of DeZURIK, Inc. manufacture are warranted to the original purchaser for a period of twenty-four (24) months from date of shipment from factory, against defective workmanship and material, but only if properly installed, operated and serviced in accordance with DeZURIK, Inc. recommendations. Repair or replacement, at our option, for items of DeZURIK, Inc. manufacture will be made free of charge, (FOB) our facility with removal, transportation and installation at your cost, if proved to be defective within such time, and this is your sole remedy with respect to such products. Equipment or parts manufactured by others but furnished by DeZURIK, Inc. will be repaired or replaced, but only to the extent provided in and honored by the original manufacturers warranty to DeZURIK, Inc., in each case subject to the limitations contained therein. No claim for transportation, labor or special or consequential damages or any other loss, cost or damage shall be allowed. You shall be solely responsible for determining suitability for use and in no event shall DeZURIK, Inc. be liable in this respect. DeZURIK, Inc. does not guarantee resistance to corrosion, erosion, abrasion or other sources of failure, nor does DeZURIK, Inc. guarantee a minimum length of service. Your failure to give written notice to us of any alleged defect under this warranty within twenty (20) days of its discovery, or attempts by someone other than DeZURIK, Inc. or its authorized representatives to remedy the alleged defects therein, or failure to return product or parts for repair or replacement as herein provided, or failure to install and operate said products and parts according to instructions furnished by DeZURIK, Inc., or misuse, modification, abuse or alteration of such product, accident, fire, flood or other Act of God, or failure to pay entire contract price when due shall be a waiver by you of all rights under this warranty.

The foregoing guarantee shall be null and void if, after shipment from our factory, the item is modified in any way or a component of another manufacturer, such as but not limited to, an actuator is attached to the item by anyone other than DeZURIK, Inc. Factory Service personnel. All orders accepted shall be deemed accepted subject to this limited warranty, which shall be exclusive of any other or previous Warranty, and this shall be the only effective guarantee or warranty binding on DeZURIK, Inc., despite anything to the contrary contained in the purchase order or represented by any agent or employee of DeZURIK, Inc., in writing or otherwise, notwithstanding, including but not limited to implied warranties.

Metric fasteners should not be used with ASME Class 150/300 bolt holes and flange bolt patterns. If you use metric fasteners with ASME Class 150/300 bolt holes and flange bolt patterns, it may lead to product failure, injury, and loss of life. DeZURIK Inc. disclaims all liability associated with the use of metric fasteners with ASME Class 150/300 bolt holes and flange patterns, including but not limited to personal injury, loss of life, loss of product, production time, equipment, property damage, lost profits, consequential damages of any kind and environment damage and/or cleanup. Use of metric fasteners with ASME Class 150/300 bolt holes and flange bolt patterns is a misuse that voids all warranties and contractual assurances. If you use metric fasteners with ASME Class 150/300 bolt holes and flange bolt patterns, you do so at your sole risk and any liability associated with such use shall not be the responsibility of DeZURIK, Inc. In addition to the foregoing, DeZURIK's Manufacturer's Conditions apply.

THE FOREGOING REPAIR AND REPLACEMENT OBLIGATIONS ARE IN LIEU OF ALL OTHER WARRANTIES, OBLIGATIONS AND LIABILITIES, INCLUDING ALL WARRANTIES OF FITNESS FOR A PARTICULAR PURPOSE OR OF MERCHANTABILITY OR OTHERWISE, EXPRESSED OR IMPLIED IN FACT OR BY LAW, AND STATE DEZURIK, INC.'S ENTIRE AND EXCLUSIVE LIABILITY AND YOUR EXCLUSIVE REMEDY FOR ANY CLAIM IN CONNECTION WITH THE SALE AND FURNISHING OF SERVICES, GOODS OR PARTS, THEIR DESIGN, SUITABILITY FOR USE, INSTALLATION OR OPERATIONS.

Limitation of liability

LIMITATION OF LIABILITY: IN NO EVENT SHALL DEZURIK, INC. BE LIABLE FOR ANY DIRECT, INDIRECT, SPECIAL OR CONSEQUENTIAL DAMAGES WHATSOEVER, AND DEZURIK, INC.'S LIABILITY, UNDER NO CIRCUMSTANCES, WILL EXCEED THE CONTRACT PRICE FOR THE GOODS AND/OR SERVICES FOR WHICH LIABILITY IS CLAIMED. ANY ACTION BY YOU FOR BREACH OF CONTRACT MUST BE COMMENCED WITHIN 12 MONTHS AFTER THE DATE OF SALE.

Sales and Service

For information about our worldwide locations, approvals, certifications and local representative:

Web site: www.dezurik.com E-Mail: info@dezurik.com



250 Riverside Ave. N., Sartell, MN 56377 • Phone: 320-259-2000 • Fax: 320-259-2227

DeZURIK, Inc. reserves the right to incorporate our latest design and material changes without notice or obligation. Design features, materials of construction and dimensional data, as described in this manual, are provided for your information only and should not be relied upon unless confirmed in writing by DeZURIK, Inc. Certified drawings are available upon request.