

Helios PD2-7000 Temperature Meter

Instruction Manual



HELIOS



MeterView Pro

USB Install

- Large Display NEMA 4X, IP65 Wall Mounted Temperature Meter
- J, K, T, E, R, S, B, N, C Thermocouples
- 100 or 1000 Ω Platinum, 10 Ω Copper, 120 Ω Nickel RTDs
- 1° or 0.1° Resolution
- Optional Isolated 4-20 mA Output Turns the Meter into a Temperature Transmitter
- Averages up to 10 RTD Sensors
- Automatic Cold Junction Compensation
- Large Dual-Line 6-Digit Display, 1.8" (46 mm) Digits Readable up to 100 Feet (30 Meters) Away
- 4 Relays with Interlocking Capability + Isolated 4-20 mA Output Option
- Free PC-Based, On-Board, MeterView Pro USB Programming Software
- SunBright Display Standard Feature; Great for Outdoor Applications
- Operating Temperature Range: -20 to 65°C (-4 to 149°F)
- Conformal Coated PCBs for Dust and Humidity Protection
- UL & C-UL Listed. E160849; 508 Industrial Control Equipment
- Input Power Options: 85-265 VAC / 90-265 VDC or 12-24 VDC / 12-24 VAC
- Programmable Display, Function Keys & Digital Inputs
- On-Board RS-485 Serial Communications
- Modbus RTU Communication Protocol Standard
- 5 Digital Inputs & 4 Digital Outputs Standard
- Password Protection
- Light / Horn & Button Accessory
- Control Station Accessory For Remote Operation
- 3-Year Warranty

PRECISION DIGITAL CORPORATION

233 South Street • Hopkinton MA 01748 USA
Tel (800) 343-1001 • Fax (508) 655-8990

www.predig.com

**PRECISION
DIGITAL**

Disclaimer

The information contained in this document is subject to change without notice. Precision Digital makes no representations or warranties with respect to the contents hereof and specifically disclaims any implied warranties of merchantability or fitness for a particular purpose. See Warranty Information and Terms & Conditions on www.prediq.com for complete details.

CAUTION

- Read complete instructions prior to installation and operation of the meter.

WARNINGS

- Risk of electric shock or personal injury.
- This product is not recommended for life support applications or applications where malfunctioning could result in personal injury or property loss. Anyone using this product for such applications does so at his/her own risk. Precision Digital Corporation shall not be held liable for damages resulting from such improper use.

WARNING

Cancer and Reproductive Harm - www.P65Warnings.ca.gov

Limited Warranty

Precision Digital Corporation warrants this product against defects in material or workmanship for the specified period under "Specifications" from the date of shipment from the factory. Precision Digital's liability under this limited warranty shall not exceed the purchase value, repair, or replacement of the defective unit. See Warranty Information and Terms & Conditions on www.prediq.com for complete details.

Registered Trademarks

All trademarks mentioned in this document are the property of their respective owners.

© 2021 Precision Digital Corporation. All rights reserved.

FREE MeterView Pro Programming Software



The meter can be powered from the USB connection. When using the USB connection, **DO NOT** apply AC or DC power to the meter.

The easiest and quickest way to program your Helios meter is to use the FREE MeterView Pro programming software. This software is loaded into the meter and connects and installs directly to your PC with a USB cable. We recommend that the first thing you do after taking the meter out of the box is connect the Helios to your PC with the provided USB cable – do not use a different cable. **DO NOT** apply AC or DC power to the meter while your PC is connected to the meter as it will disrupt the USB connection. You don't even have to apply an input signal.

MeterView Pro programming software is intuitive, and most customers can get their meter programmed as they like without even looking in the manual.

Watch MeterView Pro Software Video at www.prediq.com/meterviewpro

In addition to programming, the software may be used for:

- Monitoring
- Datalogging using your PC
- Generating and saving programming files for later use

Once your meter is programmed the way you want it, you can wire it up for your application per the instructions in this manual and install it. If you find that you need to make adjustments to the programming after the meter is installed, you can use the programming buttons and the instructions in this manual to do so.

Table of Contents

Introduction	6
Ordering Information	6
Specifications.....	8
General	8
Temperature Input	9
Relays	9
USB Connection	9
Isolated 4-20 mA Output	10
RS-485 Serial Communications	10
Modbus® RTU Serial Communications	10
Digital Input (F4)	10
Digital Inputs & Outputs	10
MeterView Pro Software	10
Compliance Information	11
Safety	11
Safety Information	11
Installation	11
Unpacking	11
Wall Mounting Instructions	12
Mounting Dimensions.....	12
Conduit Holes Location	12
Pipe Mounting Instructions	13
Installation Overview	14
MeterView Pro Software	14
MeterView Pro Installation.....	14
Connections	15
Connectors Labeling	15
Power Connections	16
Signal Connections	16
Connections for Averaging RTD Sensors	17
Relay Connections	17
Switching Inductive Loads.....	17
RS-485 Connections	18
RS-485 Multi-Drop Connection	18
RS-485 Serial Converters	18
Digital I/O Connections.....	19
F4 Digital Input Connections	19
4-20 mA Output Connections	19
Analog Output Power Supply	19
Remote Operation of Meter.....	20
Interlock Relay Feature	20
Setup and Programming	21
Overview	21
LED Status Indicators	21
Programming Buttons	22
Display Functions & Messages	23
Main Menu	24
Setting Numeric Values	25
Setting Up the Meter (SETUP)	25
Setting the Input Signal (INPUT).....	25
Selecting the Temperature Scale (F or C).....	25
Setting the Decimal Point (DEC PT).....	25
Setting the Display Parameter & Intensity (DISPLAY)	26
Display Intensity (DISPLAY).....	26
Setting the Display Units or Custom Tags (UNITS)	26

Setting the Relay Operation (rELRY)	27
Setting the Relay Action	27
Programming Set and Reset Points	28
Setting Fail-Safe Operation	28
Programming Time Delay.....	28
Relay Action for Loss of Input (Input Break).....	28
Relay and Alarm Operation Diagrams	28
High Alarm Operation (Set > Reset)	28
Low Alarm Operation (Set < Reset)	28
High Alarm with Fail-Safe Operation (Set > Reset).....	29
Low Alarm with Fail-Safe Operation (Set < Reset)	29
Relay Sampling Operation	29
Signal Loss or Input Break Relay Operation	29
Time Delay Operation	30
Relay Operation Details	30
Overview	30
Relays Auto Initialization	30
Fail-Safe Operation	30
Front Panel LEDs.....	31
Latching and Non-Latching Relay Operation	31
Non-Latching Relay (RULo)	31
Non-Latching Relay with Manual Reset (R-nRn).....	31
Latching Relay (LRcH)	31
Latching Relay with Clear (Lc-Lr)	32
Acknowledging Relays	32
Setting Up the Interlock Relay (Force On) Feature	33
Scaling the 4-20 mA Analog Output (Rout)	34
Reset Menu (rESEt)	34
Manual Control Menu (Control)	34
Setting Up the Password (PR55)	35
Protecting or Locking the Meter	35
Making Changes to a Password Protected Meter	35
Disabling Password Protection.....	35
Advanced Features Menu	36
Advanced Features Menu & Display Messages.....	36
Offset Adjust (RdJusE)	37
Recalibration of the Meter (t CLR).....	37
Noise Filter (F iLEr).....	37
Noise Filter Bypass (bYPR55).....	38
Rounding Feature (round)	38
Modbus RTU Serial Communications (5Er RL).....	38
Select Menu (SELEct).....	38
Analog Output Programming (RoutPr)	39
Programmable Function Keys User Menu (u5Er)	40
Internal Temperature Calibration (iLR)	41
Meter Operation	42
Button Operation	42
Function Keys Operation.....	42
Digital Inputs Operation	42
Maximum/Minimum Readings	42
Troubleshooting	43
Diagnostics Menu (d rG)	43
Testing the Display LEDs.....	43
Determining Software Version.....	43
Reset Meter to Factory Defaults	43
Factory Defaults & User Settings	44
Troubleshooting Tips	45

Table of Figures

Figure 1. Meter Mounting Holes Location	12
Figure 2. Meter Mounting Holes Dimensions	12
Figure 3. Meter Dimensions – Side View	12
Figure 4. Meter Dimensions - Front View	12
Figure 5. Conduit Holes Location – Bottom View.....	12
Figure 6. Vertical Pipe Mount Assembly.....	13
Figure 7. Horizontal Pipe Mount Assembly	13
Figure 8. PD2-7000-6H0 / 7H0 Connectors Label	15
Figure 9. PD2-7000-6H7 / 7H7 Connectors Label	15
Figure 10. Power Connections	16
Figure 11. Thermocouple Input Connections.....	16
Figure 12. Three-Wire RTD Input Connections	16
Figure 13. Two-Wire RTD Input Connections.....	16
Figure 14. Four-Wire RTD Input Connections.....	16
Figure 15. Average Temperature RTD Input Connections	17
Figure 16. Relay Connections.....	17
Figure 17. AC and DC Loads Protection.....	17
Figure 18. Low Voltage DC Loads Protection	17
Figure 19. RS-485 Connection	18
Figure 20. Five-Wire RS-485 Connections.....	18
Figure 21. Three-Wire RS-485 Multi-Drop Connections	18
Figure 22. Connections for RS-485 Connector to Serial Converter	19
Figure 23. Three-Wire RS-485 Connection	19
Figure 24. Digital Input and Output Connections	19
Figure 25. F4 Digital Input Connections	19
Figure 26. 4-20 mA Output Connections	19
Figure 27. Analog Output Supply Powering Other Devices.....	19
Figure 28. Meter to PDA2364-MRUE Control Station Connection.....	20
Figure 29. Interlock Connections	20

Introduction

The Helios PD2-7000 is a multi-purpose, easy to use, large-display digital temperature meter. It features large 1.8 inch superluminous LED digits, which can be read in direct sunlight from up to 100 feet (30 meters) away. It is housed in a water-resistant, field mountable NEMA 4X/IP65 rated enclosure for convenient indoor and outdoor installation.

The programming buttons are located behind the lower panel door and are not generally accessible during operation. For that reason, we recommend the use of the PDA2364-MRUE remote control station which has four buttons to mimic the buttons behind the panel.

The meter accepts type J, K, T, E, R, S, B, N, and C thermocouples as well as 100 or 1000 Ω platinum, 10 Ω copper, and 120 Ω nickel RTDs. Three of the programming buttons can be set for custom operation. The meter features automatic cold junction compensation for thermo-couples and can average up to 10 RTD sensors for precision temperature measurement.

The PD2-7000 can be equipped with an optional 4-20 mA output that turns a temperature meter into an isolated temperature transmitter with a big, bright display!

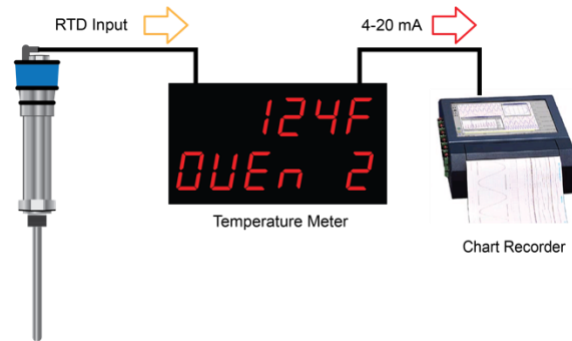

The PD2-7000 includes automatic cold junction compensation for thermocouples and the ability to average up to ten RTD sensors.

A fully loaded Helios PD2-7000 temperature meter comes with four SPDT relays, a 4 20 mA output, two 24 VDC power supplies, five digital inputs and four digital outputs, and RS-485 serial communications.

The four relays can be used for alarm indication or temperature control applications. The large display size, ease of readability, Modbus RTU serial communications, and digital I/O features make the Helios an excellent addition to any system.

Ordering Information

85-265 VAC Models

Model	Standard Features	Options Installed
PD2-7000-6H0	5 Digital Inputs, 4 Digital Outputs, RS-485 Communications	No options
PD2-7000-6H7		4 relays 4-20 mA output

12-24 VDC Models

Model	Standard Features	Options Installed
PD2-7000-7H0	5 Digital Inputs, 4 Digital Outputs, RS-485 Communications	No options
PD2-7000-7H7		4 relays 4-20 mA output

Accessories

Model	Description
PDA0004	Cable Gland
PDA7485-I	RS-232 to RS-485 isolated converter
PDA8485-I	USB to RS-485 isolated converter
PDAPLUG2	Plastic Conduit Plug
PDX6901	Snubber: 0.01 μF/470 Ω, 250 VAC

PDA2360 Control Stations



Model	Description
PDA2360-E	Emergency button
PDA2361-A	Ack button
PDA2361-B	Blank button
PDA2361-R	Reset button
PDA2361-T	Tare button
PDA2361-S	Stop button
PDA2361-Q	Silence button
PDA2362-AR	Ack and Reset buttons
PDA2362-BB	Two blank buttons
PDA2364-MRUE	Menu, right, up, enter buttons

Note: Control stations can be connected directly to the Helios meter's on-board digital inputs. See *Remote Operation of Meter* on page 20 for details.

Light / Horn & Button Accessories



Helios Meter Shown with MOD-PD2LHRB1 Red Light / Horn and Button. Meter Sold Separately.

Model	Description
MOD-PD2LHRB1	Red Light / Horn and Button Mounted and Wired to Helios ⁽¹⁾
MOD-PD2LHGB1	Green Light / Horn and Button Mounted and Wired to Helios ⁽¹⁾
MOD-PD2LHYB1	Yellow Light / Horn and Button Mounted and Wired to Helios ⁽¹⁾
MOD-PD2LHBB1	Blue Light / Horn and Button Mounted and Wired to Helios ⁽¹⁾
MOD-PD2LHWB1	White Light / Horn and Button Mounted and Wired to Helios ⁽¹⁾
MOD-PD2LH5CB1	Light / Horn with User Choice of Red, Green, Yellow, Blue or White Light, Button, Mounted and Wired to Helios ⁽¹⁾
MOD-PD2LH3CB1-RYG	Light / Horn with Red, Yellow, Green Light Layers, Button, Mounted and Wired to Helios ⁽¹⁾

Note:

1. Specify MOD-PD2LH model as a separate item on the order for the Helios to order the Light / Horn & Button accessory installed and wired. Meter is sold separately.
2. An external 24 VDC power supply ([PDA1024-01](#)) is required to power the Light / Horn.



9 labels are provided for the button.

Pipe Mounting Kit



Helios Meter Shown mounted to pipe using PDA6260 pipe mounting kit. See *Pipe Mounting Instructions* on page 13 for details.

Model	Description
PDA6260	2" Pipe Mounting Kit for PD2

Signal Splitter & Conditioner Accessories



Model	Description
PD659-1MA-1MA	Signal Isolator with One 4-20 mA Input and One 4-20 mA Output
PD659-1MA-2MA	Signal Splitter with One 4-20 mA Input and Two 4-20 mA Outputs

Specifications

Except where noted all specifications apply to operation at +25°C.

General

Display	Dual-line: 1.8" (46 mm) high, red LEDs 6 digits per line (-99999 to 999999), with lead zero blanking. Temperature displayed on line 1 with four or five-digits and F/C indication, based on configuration. Example 234.12F with 0.1° resolution and 234.1°F with 1° resolution.
Resolution	1° or 0.1° for all thermocouple and RTD inputs
Display Intensity	Eight user selectable intensity levels
Display Update Rate	5/second (200 ms)
Overrange	Display flashes 99999
Underrange	Display flashes -9999
LED Status Indicators	See <i>LED Status Indicators</i> on page 21 for details.
Programming Methods	Four programming buttons, digital inputs, PC and MeterView Pro software, or Modbus registers.
Noise Filter	Programmable from 2 to 199 (0 will disable filter)
Filter Bypass	Programmable from 0.1 to 99.9% of calibrated span
Recalibration	All ranges are calibrated at the factory. Recalibration is recommended at least every 12 months.
Max/Min Display	Max/min readings reached by the process are stored until reset by the user or until power to the meter is cycled.
Rounding	Select 1, 2, 5, or 10 (e.g. rounding = 10, value = 123.45, display = 123.50).
Password	Three programmable passwords restrict modification of programmed settings. Pass 1: Allows use of function keys and digital inputs Pass 2: Allows use of function keys, digital inputs and editing set/reset points Pass 3: Restricts all programming, function keys, and digital inputs.
Non-Volatile Memory	All programmed settings are stored in non-volatile memory for a minimum of ten years if power is lost.
Power Options	85-265 VAC 50/60 Hz; 90-265 VDC, 20 W max; 12-24 VDC, 12-24 VAC, 15 W max. Powered over USB for configuration only.
Fuse	Required external fuse: UL Recognized, 5 A max, slow blow; up to 6 meters may share one 5 A fuse
Normal Mode Rejection	Greater than 60 dB at 50/60 Hz
Isolation	4 kV input/output-to-power line 500 V input-to-output

Overvoltage Category	Installation Overvoltage Category II: Local level with smaller transient overvoltages than Installation Overvoltage Category III.
Connections	Power, signal, relays, mA out: Removable screw terminal blocks accept 12 to 22 AWG wire. RS-485: Removable screw terminal block accepts 16 to 30 AWG wire. Digital I/O: Non-removable screw terminal blocks accept 16 to 30 AWG wire.
Enclosure	UL Type 4X, IP65 rated. Polycarbonate & glass blended plastic case, color: gray. Includes four PG11 through-hole conduit openings, with two factory installed PG11, IP68, black nylon threaded hole plugs with backing nuts.
Mounting	Wall Mounting: Four (4) mounting holes provided for mounting meter to wall. See <i>Wall Mounting Instructions</i> on page 12 for additional details. Pipe Mounting: Optional pipe mounting kit (PDA6260) allows for pipe mounting. Sold separately. See <i>Pipe Mounting Instructions</i> on page 13 for additional details.
Tightening Torque	Power, signal, relays, mA out terminals: 5 lb-in (0.56 Nm) Digital I/O and RS-485: 2.2 lb-in (0.25 Nm)
Overall Dimensions	10.63" x 12.59" x 4.77" (270 mm x 319.7 mm x 121.2 mm) (W x H x D)
Weight	6.10 lbs (2.76 kg)
Warranty	3 years parts & labor. See Warranty Information and Terms & Conditions on www.predig.com for complete details.

Temperature Input

Inputs	Thermocouple: J, K, T, E, R, S, B, N, C RTD: 100 Ω platinum (0.00385 & 0.00392 coefficients), 10 Ω copper, 120 Ω nickel, 1000 Ω platinum (0.00385 & 0.00392 coefficients)
Cold Junction Reference	Automatic, fixed, no user calibration needed
Temperature Drift	±2°C maximum from 0 to 65°C ambient temperature ±4°C maximum from -20 to 0°C ambient temperature
Offset Adjustment	User programmable offset adjust ±50.0 degrees. This parameter allows the user to apply an offset value to the temperature being displayed.
Input Impedance	Greater than 100 kΩ
Sensor Break Detection	Open TC or RTD sensor indicated by display flashing $\sigma P E n$, relays can be programmed to go "On", "Off", or to "Ignore" (Note: Ignore is detected as an upscale condition). Analog output goes to the programmed sensor break value.
RTD Averaging	Up to 10 RTDs connected in parallel can be averaged.

Accuracy & Ranges

Type	Range (°F)	Accuracy	Range (°C)	Accuracy
J	-200 to 2000	±1.8°F	-129 to 1093	±1°C
K	-200 to 2400	±1.8°F	-129 to 1316	±1°C
T	-200 to 752	±1.8°F	-129 to 400	±1°C
E	-200 to 1800	±1.8°F	-129 to 982	±1°C
R	-50 to 3000	±3.6°F	-46 to 1649	±2°C
S	-50 to 3000	±3.6°F	-46 to 1649	±2°C
B	752 to 3300	±3.6°F	400 to 1816	±2°C
N	-100 to 2300	±3.6°F	-73 to 1260	±2°C
C	32 to 4100	±3.6°F	0 to 2260	±2°C
10Ω	-328 to 500	±0.2°F	-200 to 260	±0.1°C
100Ω	-328 to 1562	±0.7°F	-200 to 850	±0.4°C
120Ω	-110 to 500	±0.2°F	-79 to 260	±0.1°C
1000Ω	-328 to 900	±0.7°F	-200 to 482	±0.4°C

All ranges capable of 1° or 0.1° resolution.

Relays

Rating	4 SPDT (Form C) internal and rated 3 A @ 30 VDC and 125/250 VAC resistive load; 1/14 HP (≈ 50 W) @ 125/250 VAC for inductive loads
Noise Suppression	Noise suppression is recommended for each relay contact switching inductive loads. See <i>Switching Inductive Loads</i> on page 17 for details.
Deadband	0-100% of span, user programmable
High or Low Alarm	User may program any alarm for high or low trip point. Unused alarm LEDs and relays may be disabled (turn off).
Relay Operation	<ul style="list-style-type: none"> Automatic (non-latching) and/or manual reset Latching (requires manual acknowledge) with or without clear Pump alternation control (2-4 relays) Sampling (based on set point and time) Off (disable unused relays and enable Interlock feature) Manual on/off control mode
Relay Reset (Acknowledge)	User selectable via front panel button, F4 digital input, external contact closure on digital inputs, or through serial communications.
Time Delay	0 to 999.9 seconds, on & off relay time delays. Programmable and independent for each relay
Fail-Safe Operation	Programmable and independent for each relay. <i>Note: Relay coil is energized in non-alarm condition. In case of power failure, relay will go to alarm state.</i>
Auto Initialization	When power is applied to the meter, relays will reflect the state of the input to the meter.

USB Connection

Function	Programming only
Compatibility	USB 2.0 Standard, Compliant
Connector Type	Type B receptacle
Cable	USB Type A-B cable
Driver	Microsoft® Windows® XP/Vista/7/8/10
Power	USB port provides power to the meter. DO NOT apply AC or DC power to the meter while the USB port is in use.

Isolated 4-20 mA Output

Output Source	PV (temperature), max, min, set points 1-4, Modbus PV input, or manual control mode		
Scaling Range	1.000 to 23.000 mA for any display range		
Calibration	Factory calibrated: 0.0 to 2000.0 = 4-20 mA output		
Analog Output Programming	23.000 mA maximum for all parameters: Overrange, underrange, max, min, and break		
Accuracy	± 0.1% of span ± 0.004 mA		
Temperature Drift	0.4 µA/°C max from 0 to 65°C ambient, 0.8 µA/°C max from -20 to 0°C ambient <i>Note: Analog output drift is separate from input drift.</i>		
Power Supply for Analog Output Loop Or Other Uses	Terminals I+ & R: 24 VDC ± 10%. May be used to power the 4-20 mA output or other devices. All models rated @ 40 mA max.		
External Loop Power Supply	35 VDC maximum		
Output Loop Resistance	Power supply	Minimum	Maximum
	24 VDC	10 Ω	700 Ω
	35 VDC (external)	100 Ω	1200 Ω
Additional 4-20 mA Outputs	The PD659-1MA-2MA can split the optional 4-20 mA output into two isolated 4-20 mA outputs		
0-10 VDC Output	The PD659-1MA-1V can convert the optional 4-20 mA output to a 0-10 VDC output		

RS-485 Serial Communications

Compatibility	EIA-485
Connectors	Removable screw terminal connector
Max Distance	3,937' (1,200 m) max
Status Indication	Separate LEDs for Power (P), Transmit (TX), and Receive (RX)

Modbus® RTU Serial Communications

Slave Id	1 – 247 (Meter address)
Baud Rate	300 – 19,200 bps
Transmit Time Delay	Programmable between 0 and 199 ms
Data	8 bit (1 start bit, 1 or 2 stop bits)
Parity	Even, Odd, or None with 1 or 2 stop bits
Byte-To-Byte Timeout	0.01 to 2.54 sec
Turn Around Delay	Less than 2 ms (fixed)

Note: Refer to the Helios Modbus Register Tables located at www.prediq.com for details.

Digital Input (F4)

Function	Remote operation of front-panel buttons, acknowledge/reset relays, reset max/min values. See <i>Function Keys & Digital I/O Available Settings</i> on page 40 for a complete list of capabilities.
Contacts	3.3 VDC on contact. Connect normally open contacts across F4 to COM
Logic Levels	Logic High: 3 to 5 VDC Logic Low: 0 to 1.25 VDC

Digital Inputs & Outputs

Function	Terminals provided for remote operation of all four programming / operation buttons (use PDA2364-MRUE control station). Other uses include acknowledge/reset relays and reset max/min values. See <i>Function Keys & Digital I/O Available Settings</i> on page 40 for a complete list of capabilities.
Channels	4 digital inputs & 4 digital outputs
Digital Input Logic High	3 to 5 VDC
Digital Input Logic Low	0 to 1.25 VDC
Digital Output Logic High	3.1 to 3.3 VDC
Digital Output Logic Low	0 to 0.4 VDC
Source Current	10 mA maximum output current
Sink Current	1.5 mA minimum input current
+5 V Terminal	To be used as pull-up for digital inputs only. Connect normally open push buttons across +5 V & DI 1-4.

WARNING

- **DO NOT** use +5 V terminal to power external devices.

MeterView Pro Software

Availability	Download directly from meter or from www.prediq.com/download_software
System Requirements	Microsoft® Windows® XP/Vista/7/8/10
Communications	USB 2.0 (for programming only) (Standard USB A to USB Type B) RS-485 to USB converter (programming, monitoring, and data logging)
Configuration	Configure meters one at a time
Power	USB port provides power to the meter. DO NOT apply AC or DC power to the meter while the USB port is in use.

Compliance Information

Safety

UL & C-UL Listed	USA & Canada UL 508 Industrial Control Equipment (USA) C22.2 No. 142 (Canadian National Standard)
UL File Number	E160849
Enclosure	UL Type 4X, NEMA 4X, IP65
Low Voltage Directive	EN 61010-1 Safety requirements for measurement, control, and laboratory use

Safety Information

⚠ CAUTION

- Read complete instructions prior to installation and operation of the meter.

⚠ WARNINGS

- Risk of electric shock or personal injury.
- Hazardous voltages exist within enclosure. Installation and service should be performed only by trained service personnel.

Installation

There is no need to open the clear plastic front cover in order to complete the installation, wiring, and setup of the meter. All programming is done using [MeterView Pro](#) software or through the buttons and switches located under the lower door panel and are accessible by removing the single securing screw. Wires should be run through the knockout holes located on the bottom of the meter, see *Figure 5. Conduit Holes Location – Bottom View* on page 12 for details.

There are a total of four pre-drilled conduit entry holes located at the bottom of the meter. If the need to drill additional holes arises, make sure you will have the clearance necessary for conduit mounting hardware.

Do not disconnect the RJ45 connector found on the right side of the meter wiring board. Doing so will disable the on-board digital I/O, RS-485 serial communications, and M-Link functionality.

Unpacking

Remove the meter from box. Inspect the packaging and contents for damage. Report damages, if any, to the carrier. If any part is missing or the meter malfunctions, please contact your supplier or the factory for assistance.

Wall Mounting Instructions

The meter can be mounted to any wall using the four provided mounting holes. Note that the bottom mounting holes are located underneath the lower door panel. To mount the meter to a wall, follow these instructions

- Prepare a section of wall approximately 11" x 13" (280 mm x 330 mm) for meter mounting by marking with a pencil the mounting holes (shown in *Figure 1*) on the wall.
- Select the appropriate mounting screws for the mounting surface to be used. The mounting holes diameter is shown on *Figure 2*.
Note: Mounting screws are not included.
- Using a drill bit slightly smaller than the girth of the mounting screws, pre-drill holes at the mounting locations previously marked.
- Insert mounting screws into the four mounting holes and screw them into the pre-drilled holes. **DO NOT** overtighten the mounting screws as it is possible that the enclosure could crack and become damaged.

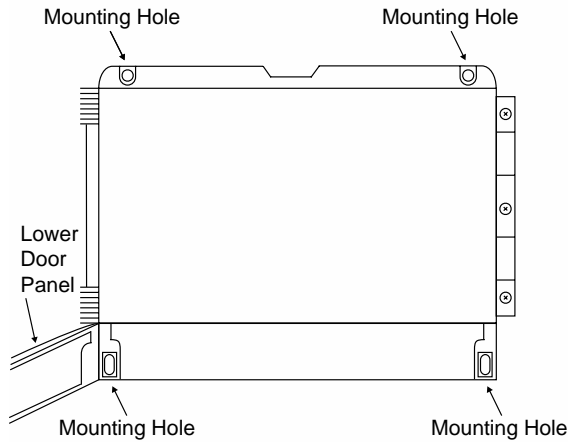

Figure 1. Meter Mounting Holes Location

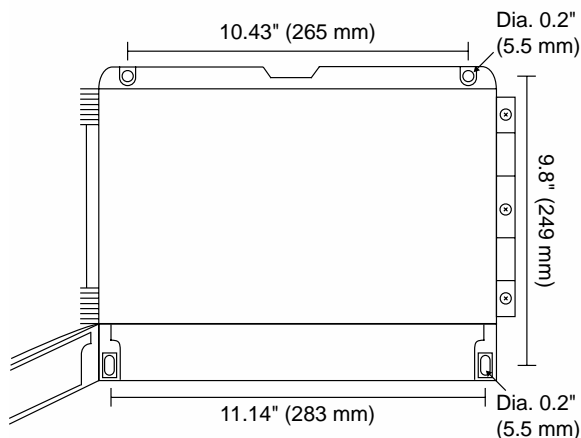

Figure 2. Meter Mounting Holes Dimensions

Mounting Dimensions

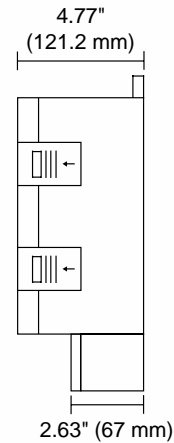

Figure 3. Meter Dimensions – Side View

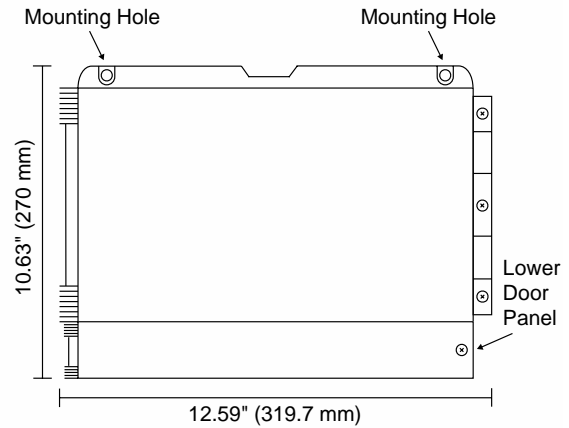

Figure 4. Meter Dimensions - Front View

Conduit Holes Location

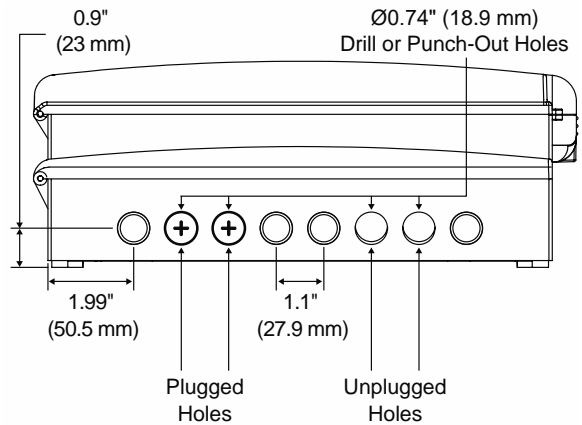

Figure 5. Conduit Holes Location – Bottom View

Pipe Mounting Instructions

The meter can also be mounted to a pipe using the optional pipe mounting kit ([PDA6260](#)). This kit includes two mounting plates, two U-bolts, and the necessary nuts and bolts. To mount the meter to a pipe using the pipe mounting kit accessory, follow these instructions.

- Secure the mounting plates to the top and bottom (for vertical pipes) or left and right (for horizontal pipes) of the reverse side of the meter enclosure using the provided fasteners. **DO NOT** overtighten the fasteners as it could cause damage to the enclosure.
- Using the provided nuts and U-bolts, secure the mounting plates to the pipe applying enough torque such that the meter cannot be moved up or down (or side to side).

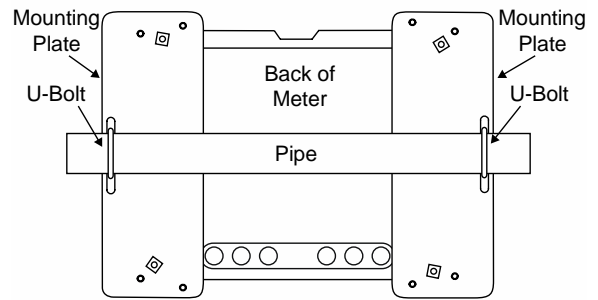
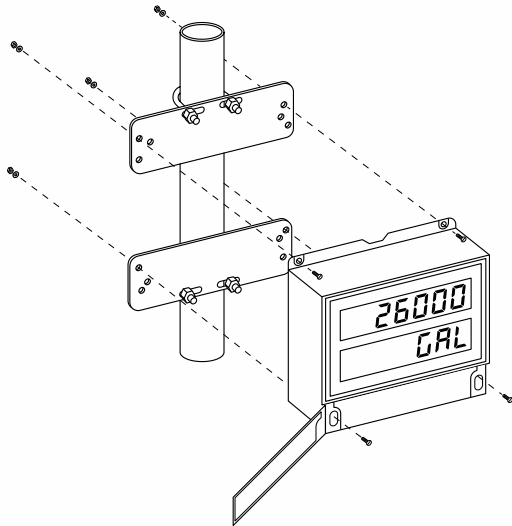
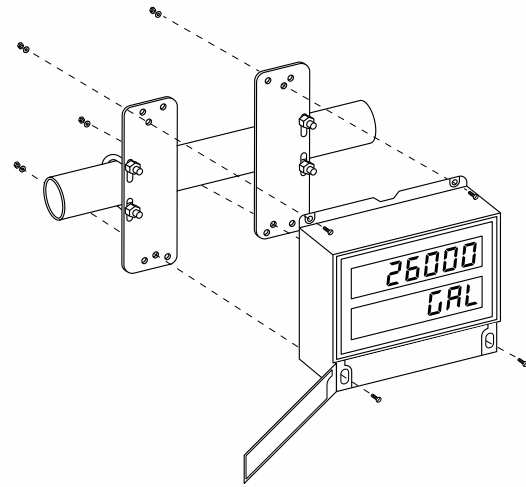

Figure 7. Horizontal Pipe Mount Assembly

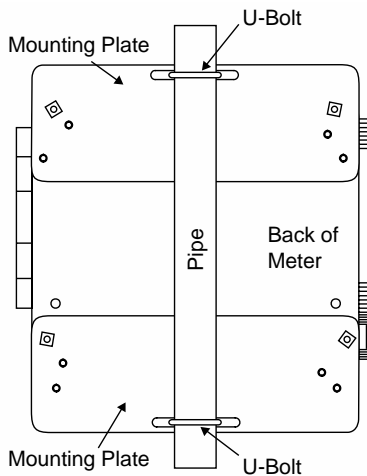

Figure 6. Vertical Pipe Mount Assembly

Installation Overview

We recommend the following sequence for getting the meter into service:

1. **DO NOT** apply AC or DC power to the meter.
2. Connect the meter to the PC with the USB cable provided. **DO NOT** use a different USB cable.
3. If MeterView Pro (MVPro) is already installed in your computer, then the program will launch automatically in most systems. If the program does not start automatically, double-click on the MVPro icon.
4. If MVPro is not installed, follow the instructions provided below.
5. Use MVPro to configure the meter for your application.
6. Disconnect the USB cable from the meter.
7. Apply power and signal and check operation of the meter.
8. Install the meter and put into service.
9. Make any programming adjustments using the programming buttons.

MeterView Pro Software

The easiest and quickest way to program your Helios meter is to use the FREE MeterView Pro programming software. This software is loaded into the meter and connects and installs directly to your PC with the USB cable provided. **DO NOT** use a different USB cable. We recommend that the first thing you do after taking the meter out of the box is connect the Helios to your PC with the provided USB cable. **DO NOT** apply AC or DC power to the meter while your PC is connected to the meter as it will disrupt the USB connection. It is not necessary to apply an input signal.

MeterView Pro programming software is intuitive, and most customers can get their meter programmed as they like without even looking in the manual.

Watch Meterview Pro Software Video at www.prediq.com/meterviewpro

MeterView Pro Installation

1. Connect one end of the provided USB cable to the meter and the other end to the computer. The computer will automatically install the driver software it needs to talk to the meter. Follow the on-screen instructions and allow sufficient time for the process to complete. This can take a few minutes. If the process is interrupted, then it could leave the system in an unstable condition.

⚠ WARNINGS

- Only one meter may be connected at a time. Attaching multiple meters will cause a conflict with the meter software.
- **DO NOT** apply AC or DC power to the meter when using the USB connection.

2. Once the driver is installed, an AutoPlay dialog should appear for the drive "MAINSTAL." Click "Open folder to view files."

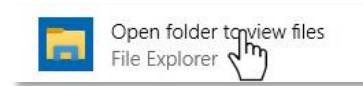

If the computer does not display an AutoPlay dialog for the drive "MAINSTAL," you should open My Computer and double-click on the drive labeled "MAINSTAL."

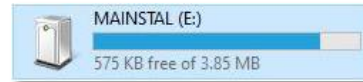

3. Double-click on the file named "MAStart." The program will open a few windows and install two programs on your computer. Simply follow the on-screen instructions until you see one of the dialogs below. If you receive a "User Account Control" warning, click "Yes."

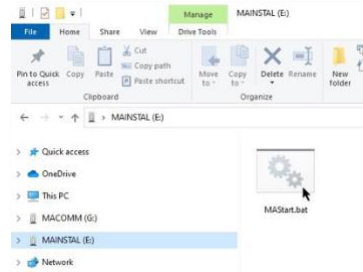

4. If there is an update available, click the "Update" button to install the new version. Otherwise, click "Configure" to begin programming your meter.

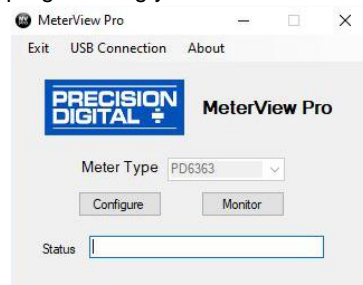

Note: If you decide to update your MeterView Pro software, once the installation has completed, you will be asked if you want to update the setup files located on the meter itself. This way, you will always have the most current version on the meter for future installs.

⚠ WARNING

- **DO NOT** unplug the meter while the new installation files are being written to it. The meter will display **⚠ E** during the process and you will receive an on-screen notification once the process is complete.

Connections

All connections are made to screw terminal connectors located under the lower door panel. Remove the single securing screw in order to access the wiring terminals.

CAUTION

- Use copper wire with 60°C or 60/75°C insulation for all line voltage connections. Observe all safety regulations. Electrical wiring should be performed in accordance with all applicable national, state, and local codes to prevent damage to the meter and ensure personnel safety.

Connectors Labeling

The connectors' label, affixed to the inside of the lower door panel, shows the location of all connectors available with the ordered configuration.

WARNINGS

- **DO NOT** connect any equipment to the RJ45 M-LINK connector. Otherwise damage will occur to the equipment and the meter.
- **DO NOT** disconnect the RJ45 connector located to the left of the power terminal block. Doing so will disable the on-board digital I/O, and the RS-485 serial communications.

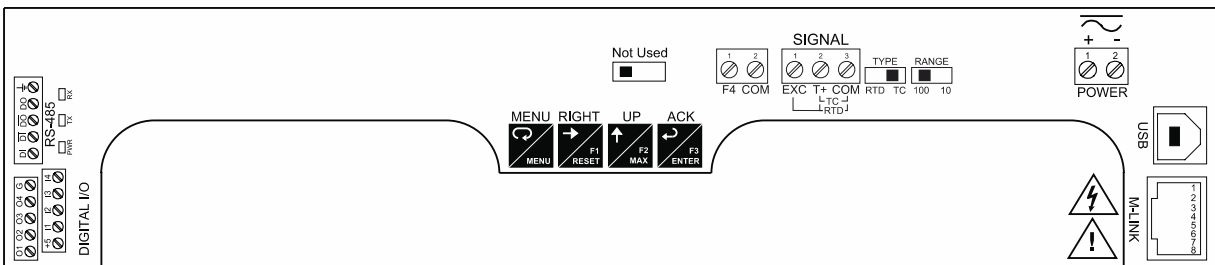

Figure 8. PD2-7000-6H0 / 7H0 Connectors Label

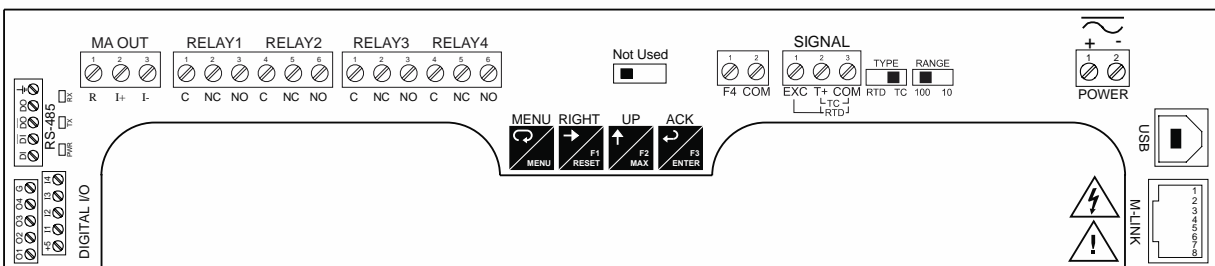

Figure 9. PD2-7000-6H7 / 7H7 Connectors Label

Power Connections

Power connections are made to a two-terminal connector labeled POWER. The meter will operate regardless of DC polarity connection. The + and - symbols are only a suggested wiring convention. There are separate models for low voltage and high voltage power. See *Ordering Information* on page 6 for details.

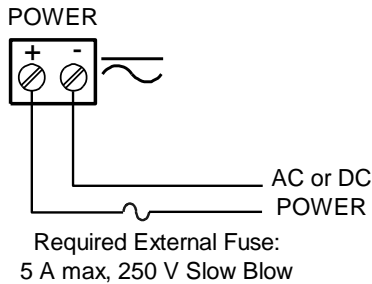

Figure 10. Power Connections

Signal Connections

Signal connections are made to a three-terminal connector labeled SIGNAL.

Thermocouple and RTD Connections

The following figures show examples for thermocouple and RTD connections.

The TYPE selector switch must be set to the proper position for the meter to accept the selected RTD or TC input.

The RANGE selector switch is used to select 100-ohm platinum or 10-ohm copper RTD. The 1000-ohm platinum RTD input uses the same setting as the 100-ohm RTD.

The input type is selected using the *Setup* menu.

The selected thermocouple input must correspond to the thermocouple sensor and wire type used.

The meter accepts two, three, or four-wire RTDs. The three-wire RTD connection has built-in lead wire compensation.

Lead wire compensation for two-wire RTDs can be applied using the *Adjust* menu. See the *Advanced Features Menu* on page 36.

The four-wire RTD connection is similar to the three-wire. One of the leads of a four-wire RTD is not connected, and may be clipped off.

The three-wire connection provides sufficient lead wire compensation to obtain accurate readings even with long leads.

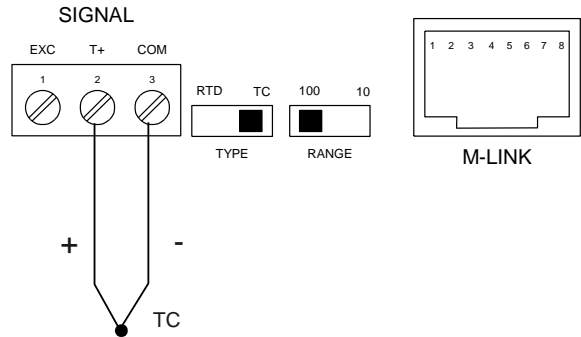

Figure 11. Thermocouple Input Connections

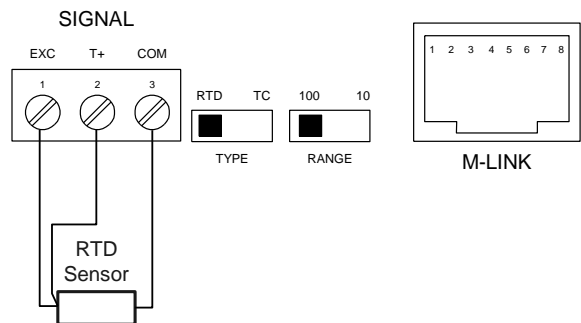

Figure 12. Three-Wire RTD Input Connections

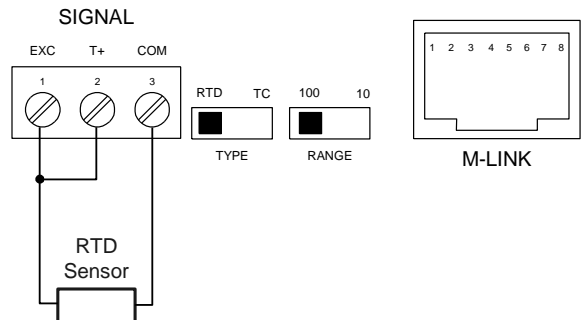

Figure 13. Two-Wire RTD Input Connections

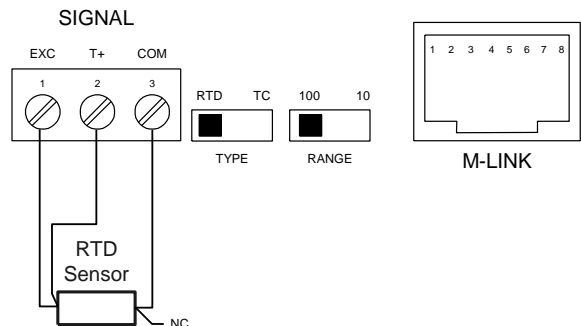

Figure 14. Four-Wire RTD Input Connections

Connections for Averaging RTD Sensors

To obtain the average temperature from 2 to 10 RTD sensors, connect all the sensors in parallel and select the number of sensors in the *RTD Total* (r t d t o t) menu. See the *Advanced Features Menu* on page 36.

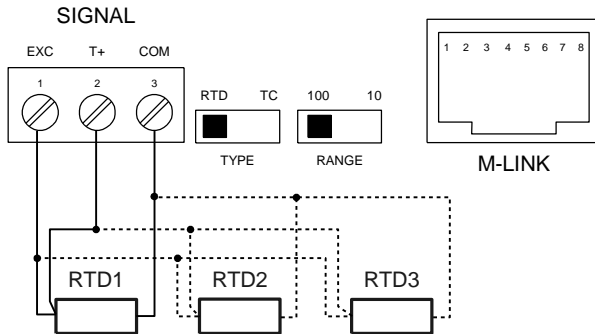

Figure 15. Average Temperature RTD Input Connections

Relay Connections

Relay connections are made to two six-terminal connectors labeled RELAY1 – RELAY4. Each relay's C terminal is common only to the normally open (NO) and normally closed (NC) contacts of the corresponding relay. The relays' C terminals should not be confused with the COM (common) terminal of the INPUT SIGNAL connector.

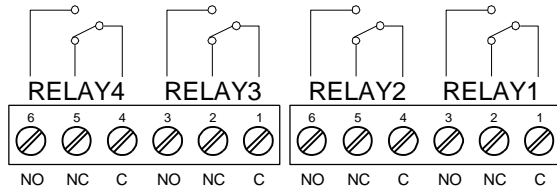

Figure 16. Relay Connections

Switching Inductive Loads

The use of snubbers to suppress electrical noise is strongly recommended when switching inductive loads to prevent disrupting the microprocessor's operation. The snubbers also prolong the life of the relay contacts. Suppression can be obtained with resistor-capacitor (RC) networks assembled by the user or purchased as complete assemblies. Refer to the following circuits for RC network assembly and installation:

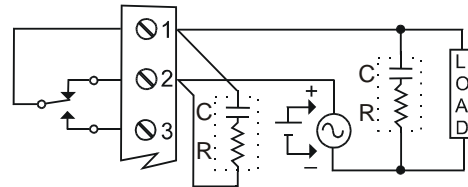

Figure 17. AC and DC Loads Protection

Choose R and C as follows:

R: 0.5 to 1 Ω for each volt across the contacts

C: 0.5 to 1 μF for each amp through closed contacts

Notes:

1. Use capacitors rated for 250 VAC.
2. RC networks may affect load release time of solenoid loads. Check to confirm proper operation.
3. Install the RC network at the meter's relay screw terminals. An RC network may also be installed across the load. Experiment for best results.

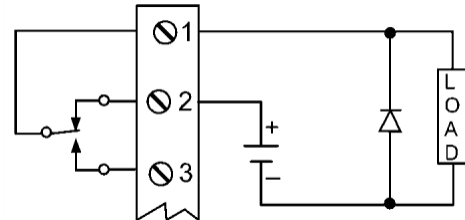

Use a diode with a reverse breakdown voltage two to three times the circuit voltage and forward current at least as large as the load current.

Figure 18. Low Voltage DC Loads Protection

RC Networks (Snubbers) Available from Precision Digital

RC networks are available from Precision Digital and should be applied to each relay contact switching an inductive load. Part number: [PDX6901](#).

Note: Relays are de-rated to 1/14th HP (50 watts) with an inductive load.

RS-485 Connections

The RS-485 connections are made to a five terminal connector used for Modbus® RTU serial communications. The RS-485 terminals include Transmit Data (DO) and (/DO), Receive Data (DI) and (/DI), and Signal Ground. See *Modbus RTU Serial Communications (SERIAL)* on page 38 for more information.

There are three diagnostic LEDs: Power (PWR) Transmit Data (TX), and Receive Data (RX) to show when the meter is transmitting and receiving data from other devices.

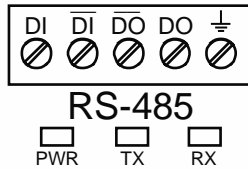

Figure 19. RS-485 Connection

RS-485 Multi-Drop Connection

When using more than one meter in a multi-drop mode, each meter must be provided with its own unique address. The meter address (Slave ID) can be programmed between 1 and 247. The transmit delay can be set between 0 and 199 ms. The parity can be set to even, odd, or none with 1 or 2 stop bits.

To change the meter address:

1. Press and hold the Menu button for three seconds to access Advanced Features menu of the meter.
2. Press Up arrow until Serial (SERIAL) menu is displayed and press Enter, ADDR-ES is displayed.
3. Press Enter to change meter address using Right and Up arrow buttons. Press Enter to accept.
4. Press Menu button to exit and return to Run Mode.

RS-485 Serial Converters

To convert the RS-485 to RS-232, use the PDA7485-I converter. To convert the RS-485 to USB, use the PDA8485-I converter. See *Ordering Information* on page 6 for additional information.

RS-485 Connection Examples

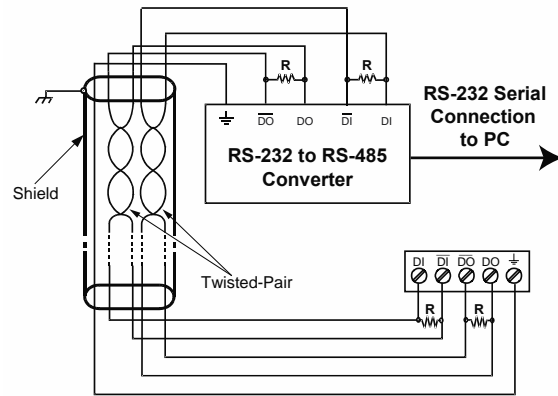

Figure 20. Five-Wire RS-485 Connections

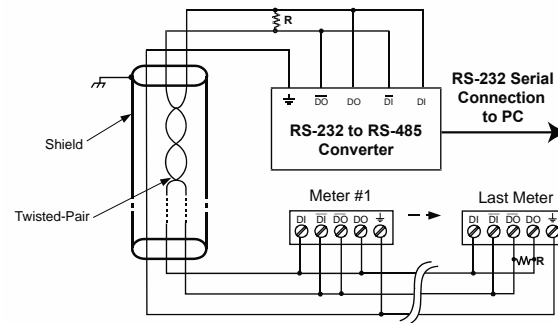

Figure 21. Three-Wire RS-485 Multi-Drop Connections

Notes:

1. Termination resistors are optional, and values depend on the cable length and characteristic impedance. Consult the cable manufacturer for recommendations.
2. Refer to RS-232 to RS-485 Converter documentation for further details.
3. Use shielded cable, twisted-pair plus ground. Connect ground shield only at one location

RS-485 Converter Connections

Figure 22 below details the wiring connections from the RS-485 connector to an RS-485 serial converter (such as the PDA7485-I or PDA8485-I) for a five-wire network.

RS-485 Connector to RS-485 Serial Converter Connections	
RS-485 Connector	RS-485 to USB or RS-232 Converter
DO	DI
DI	DO
DI	DO
DO	DI

Figure 22. Connections for RS-485 Connector to Serial Converter

Three-Wire Connection

In order to wire the five pins for use as a three-wire half-duplex RS-485 connection, it is necessary to create a jumper connection between DI to DO and /DI to /DO- as shown below.

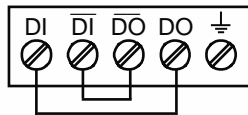

Figure 23. Three-Wire RS-485 Connection

Digital I/O Connections

Digital inputs and outputs are provided in order to expand the functionality of the meter. Digital input connections are made via a push button or switch to the appropriate digital input terminal and the +5 VDC terminal. Digital output connections are made by wiring from the appropriate digital output terminal to the ground terminal.

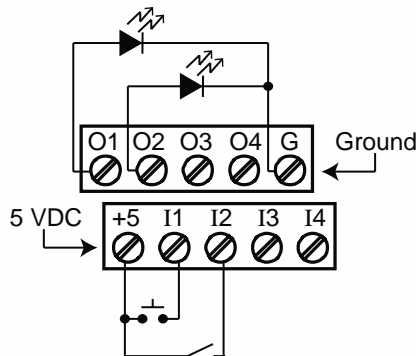

Figure 24. Digital Input and Output Connections

F4 Digital Input Connections

A digital input, F4, is standard on the meter. This digital input should be connected with a normally open closure across F4 and COM, or with an active low signal applied to F4. It can be used for remote operation of front-panel buttons, to acknowledge/reset relays, or to reset max/min values. See *Function Keys & Digital I/O Available Settings* on page 40 for a complete list of capabilities.

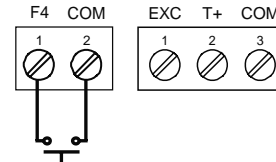

Figure 25. F4 Digital Input Connections

4-20 mA Output Connections

Connections for the 4-20 mA output are made to the connector terminals labeled mA OUT. The 4-20 mA output may be powered internally or from an external power supply.

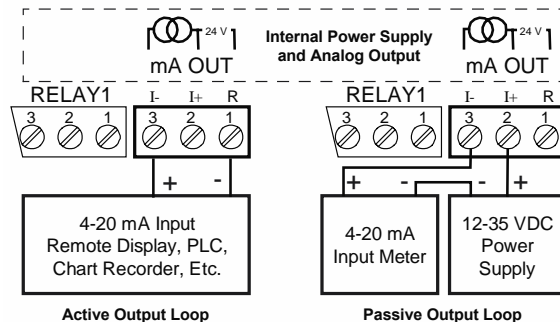

Figure 26. 4-20 mA Output Connections

Analog Output Power Supply

The internal 24 VDC power supply powering the analog output may be used to power other devices, if the analog output is not used. The I+ terminal is the +24 V and the R terminal is the return.

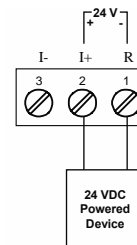

Figure 27. Analog Output Supply Powering Other Devices

Remote Operation of Meter

The meter can be operated via the programming buttons or a PDA2364-MRUE remote control station using the digital inputs and outputs connections as illustrated in *Figure 28. Meter to PDA2364-MRUE Control Station Connection*.

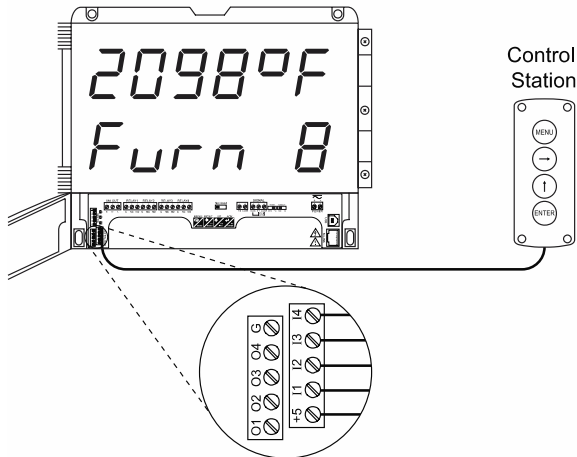

Figure 28. Meter to PDA2364-MRUE Control Station Connection

Interlock Relay Feature

As the name implies, the interlock relay feature reassigns one, or more, alarm/control relays for use as interlock relay(s). Interlock contact(s) are wired to digital input(s) and activate the interlock relay. This feature is enabled by configuring the relay, and the corresponding digital input(s), see *Setting Up the Interlock Relay (Force On) Feature* on page 32.

In the example below, an Interlock Contact switch is connected to a digital input, which will be used to force on (energize) the Interlock Relay. The Interlock Relay and the Control Relay are connected in series with the load.

- When the Interlock Contact is closed (safe), the Interlock Relay energizes, allowing power to flow to the Control Relay; the corresponding front panel LED is on.
- When the Interlock Contact is open, the corresponding front panel LED flashes (locked out), the Interlock Relay is de-energized, preventing power from flowing to the Control Relay and the load.

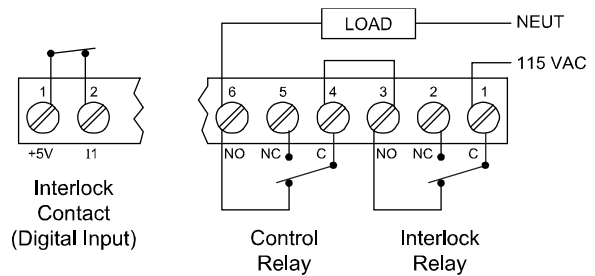

Figure 29. Interlock Connections

Setup and Programming

There is **no need to recalibrate** the meter when first received from the factory. Simply select the input type, °F or °C, and decimal point. The meter is **factory calibrated** prior to shipment to read temperature in degrees Fahrenheit with calibration equipment that is certified to NIST standards..

Overview

There are two switches, located at the back of the meter, to set the input selection for TC or RTD and for 100-ohm platinum or 10-ohm copper. The 1000-ohm RTD input uses the same setting as the 100-ohm.

Setup and programming is done using MeterView Pro or through the programming buttons.

After power and input signal connections have been completed and verified, apply power to the meter.

LED Status Indicators



LED	State	Indication
1-4	Steady	Alarm condition based on set and reset points, independent of relay status in certain configurations. (Available on all meter configurations, including those without relays installed)
1-4	Flashing	Relay interlock switch open
1-4 & M	Flashing	Relay in manual control mode
T	Flashing	Meter in Tare mode
M	Flashing	Analog output in manual control mode

Programming Buttons

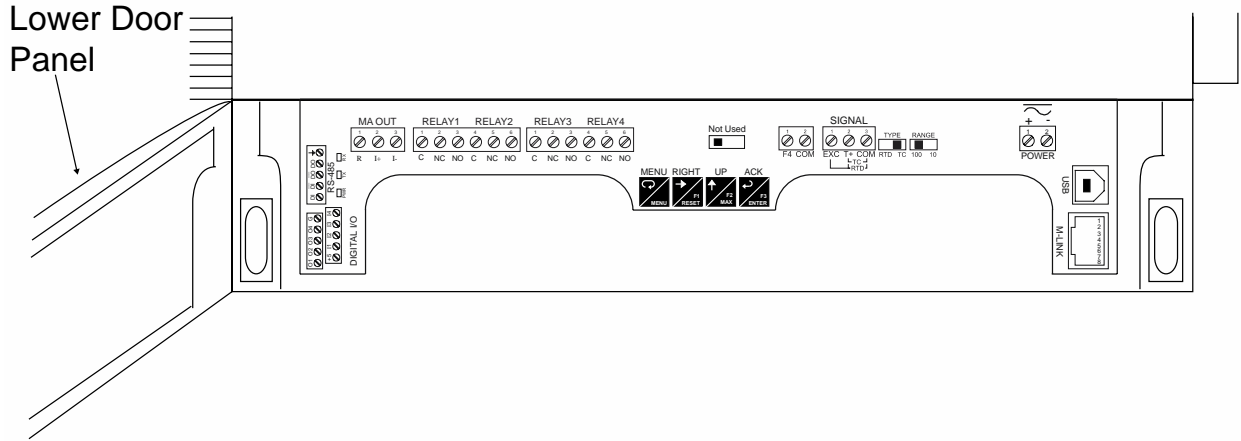

Button	Description
	Menu
	Right Arrow/F1

Button	Description
	Up Arrow/F2
	Acknowledge (Enter)/F3

- Press the Menu button to enter or exit the Programming Mode at any time.
- Press the Right arrow button to move to the next digit during digit or decimal point programming.
- Press or hold the Up arrow button to scroll through the menus, decimal point, or to increment the value of a digit.
- Press the Enter button to access a menu or to accept a setting.
- Press and hold the Menu button for three seconds to access the advanced features of the meter.



Remote Buttons

The meter can be operated via a remote control station (PDA2364-MRUE) using the digital input connections. The PDA2364-MRUE mimics the Helios’s four programming buttons: Menu, Right Arrow, Up Arrow, and Enter.

See *Remote Operation of Meter* on page 20 for details.

Display Functions & Messages

The meter displays various functions and messages during setup, programming, and operation. The following table shows the main menu functions and messages in the order they appear in the menu.

Display Functions & Messages		
Display	Parameter	Action/Setting Description
SEtUP	Setup	Enter Setup menu
InPut	Input	Enter Input selection menu
tC	TC	Set meter for thermocouple input J, K, T, E, R, S, B, N, C
rtd	RTD	Set meter for RTD input 100Pt, 1000Pt, 10Cu, 120Ni
R385	A385	Set meter for 0.00385 curve
R392	A392	Set meter for 0.00392 curve
F or C	F or C	Press Enter to select degrees F or C
units	Units	Select the display units/tags
dEc Pt	Decimal point	Set decimal point dddd, dddddd, dddd ^{oF} , dddd ^{oF}
dSPLY	Display	Enter the Display menu
Line 1	Line 1	Press Enter to assign the upper display parameter (default: PV - temperature)
Line 2	Line 2	Press Enter to assign the lower display parameter (default: engineering units)
d-IntY	Display intensity	Set display intensity level from 1 to 8
RELRY	Relay	Enter the Relay menu
rLY 1	Relay 1	Relay 1 setup
Rct 1	Action 1	Set relay 1 action
Ruto	Automatic	Set relay for automatic reset
R-nRn	Auto-manual	Set relay for automatic & manual reset any time
LRtch	Latching	Set relay for latching operation
Lt-Clr	Latching-cleared	Set relay for latching operation with manual reset only after alarm condition has cleared
RLtErn	Alternate	Set relay for alternation control
SRnPL	Sampling	Set relay for sampling operation

Display Functions & Messages		
Display	Parameter	Action/Setting Description
OFF	Off	Disable relay and front panel status LED (Select Off to enable Interlock feature)
SEt 1	Set 1	Program set point 1
rSEt 1	Reset 1	Program reset point 1
rLY 2	Relay 2	Relays 2-4 setup
FRILSF	Fail-safe	Enter Fail-safe menu
FLS 1	Fail-safe 1	Set relay 1 fail-safe operation
on	On	Enable fail-safe operation
oFF	Off	Disable fail-safe operation
FLS 2	Fail-safe 2	Set relays 2-4 fail-safe operation
dELRY	Delay	Enter relay Time Delay menu
dLY 1	Delay 1	Enter relay 1 time delay setup
On 1	On 1	Set relay 1 On time delay
OFF 1	Off 1	Set relay 1 Off time delay
dLY 2	Delay 2	Enter relays 2-4 time delay setup
brERK	Break	Set relay condition if input break detected
IgnorE	Ignore	Ignore input break condition (Processed as an upscale condition)
On	On	Relay goes to alarm condition when input break is detected
OFF	Off	Relay goes to non-alarm condition when input break is detected
Rout	Analog output	Enter the Analog output scaling menu
dS 1	Display 1	Program display 1 value
Out 1	Output 1	Program output 1 value (e.g. 4.000 mA)
dS 2	Display 2	Program display 2 value
Out 2	Output 2	Program output 2 value (e.g. 20.000 mA)
rESEt	Reset	Press Enter to access the Reset menu
rSEt Hi	Reset high	Press Enter to reset max display
rSEt Lo	Reset low	Press Enter to reset min display
rSEt HL	Reset hi/low	Press Enter to reset max & min displays

Display Functions & Messages		
Display	Parameter	Action/Setting Description
Control	Control	Enter Control menu
Auto	Automatic	Press Enter to set meter for auto operation
MAN	Manual	Press Enter to manually control relays or analog output operation
PASS		
PASS 1	Password 1	Set or enter Password 1
PASS 2	Password 2	Set or enter Password 2
PASS 3	Password 3	Set or enter Password 3
unLoc	Unlocked	Program password to lock meter
Locd	Locked	Enter password to unlock meter
99999 -99999	Flashing display	Ovrange condition Underrange condition
OPEN	Open	Open sensor indication

Main Menu

The main menu consists of the most commonly used functions: *Setup*, *Reset*, *Control*, and *Password*.

- Press Menu button to enter Programming Mode then press the Up arrow button to scroll main menu.
- Press Menu, at any time, to exit and return to Run Mode. Changes made to settings prior to pressing Enter are not saved.
- Changes to the settings are saved to memory only after pressing Enter/F3.
- The display moves to the next menu every time a setting is accepted by pressing Enter/F3.

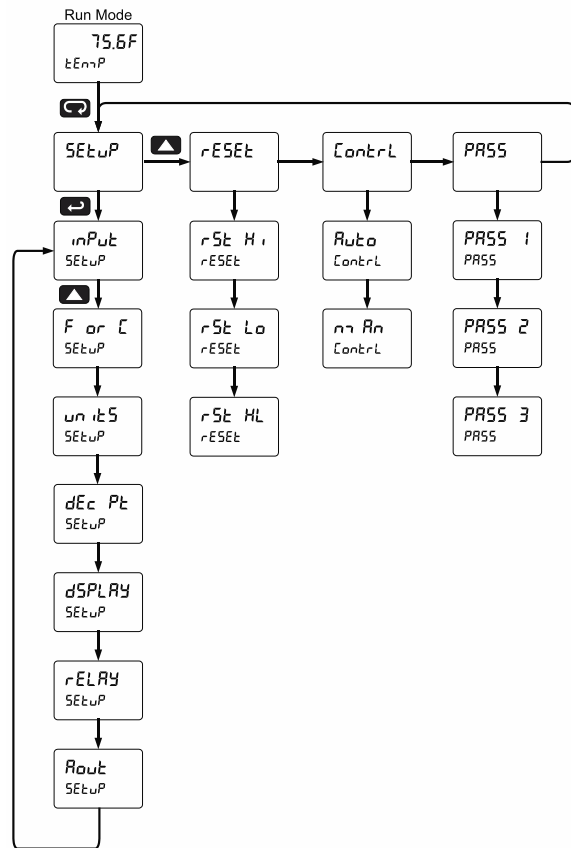

Setting Numeric Values

The numeric values are set using the Right and Up arrow buttons. Press Right arrow to select next digit and Up arrow to increment digit value. The digit being changed is displayed brighter than the rest. Press and hold up arrow to auto-increment the display value. Press the Enter button, at any time, to accept a setting or Menu button to exit without saving changes.

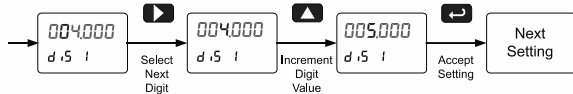

Setting Up the Meter (SEtUP)

The Setup menu is used to select:

1. Input type the meter will accept
2. Degrees F or C
3. Select the display units/tags
4. Decimal point position and F or C indication
5. Display parameter and intensity
6. Relay operation
7. 4-20 mA analog output scaling

Press the Enter button to access any menu or press Up arrow button to scroll through choices. Press the Menu button to exit at any time.

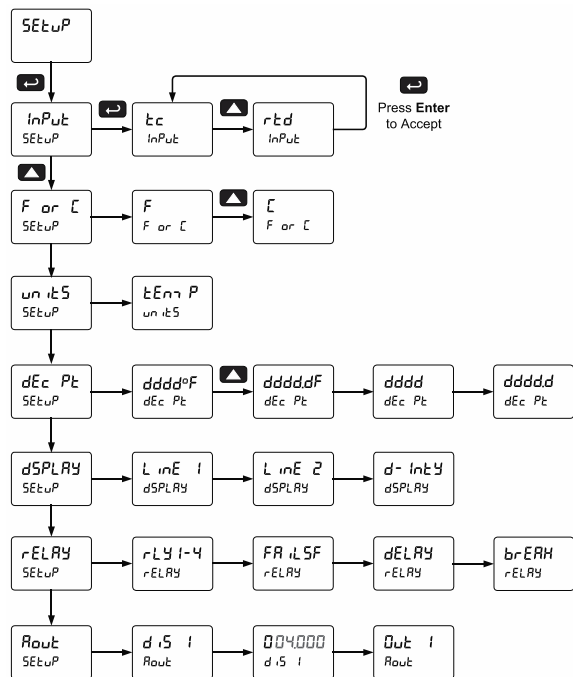

Setting the Input Signal (InPUt)

Enter the Input menu to set up the meter to accept thermocouple (tc) or RTD (rtd) inputs. The Type selector switch, located at the rear of the meter, must be set accordingly. The thermocouple input is capable of accepting various types of thermocouples. The RTD input is capable of accepting various types of RTD sensors. After selecting 100 Pt or 1000Pt, it is necessary to select either A385 (0.00385) or A392 (0.00392) coefficient.

Selecting the Temperature Scale (F or C)

The meter can display the temperature in degrees Fahrenheit or Celsius.

Setting the Decimal Point (dEc Pt)

The temperature may be displayed with one decimal or with no decimal point. The temperature scale can also be displayed with the reading. The degree symbol is available only with no decimal point selected. Pressing the Up arrow scrolls the decimal point and temperature format selections.

Setting the Display Parameter & Intensity (dSPLY)

Display line 1 (LINE 1) can be programmed to display:

1. Process value
2. Relay set points
3. Max & min values
4. Modbus input
5. Display reading and units

Display line 2 (LINE 2) can be programmed to display:

1. Process value
2. Relay set points
3. Max & min values
4. Engineering units or custom legends
5. Modbus input
6. Off (no display)
7. Display reading and units

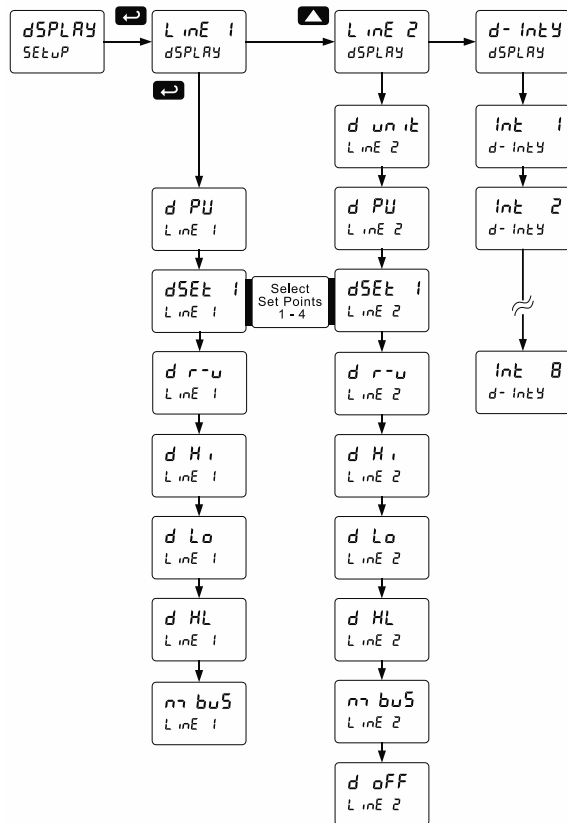

Press the Up arrow to change selection, press Enter to accept setting, and press Menu to exit programming

After setting up the input and display, press the Menu button to exit programming and skip the rest of the setup menu. Press the Menu button again and the Up arrow to reach the Setup menu again and complete the setup of the meter.

Display Intensity (d-INTY)

The meter has eight display intensity levels to give the best performance under various lighting conditions. Select intensity 8 for outdoor applications. The default intensity is 6.

Setting the Display Units or Custom Tags (uNtS)

Enter the display unit or custom tag that will be displayed if units is selected in the uNtS menu, or d u n i t is selected as the Lower display parameter. See the Setting the Display Parameter & Intensity (dSPLY) flow chart on page 26 to access the display menu to show the unit or tag on the Lower display. The engineering units or custom legends can be set using the following 7-segment character set:

Display	Character	Display	Character
	0		K
	1		L
	2		m
	3		n
	4		O
	5		o
	6		P
	7		q
	8		r
	9		S
	A		t
	b		u
	C		V
	c		w
	d		X
	E		Y
	F		Z
	G		-
	g		/
	H]
	h		[
	I		=
	i		Degree(<)
	J		Space

Notes:

1. Degree symbol represented by (<) if programming with MeterView Pro.
2. The letters "m" and "w" use two 7-segment LEDs each; when selected the characters to the right are shifted one position.
3. Press and hold up arrow to auto-scroll the characters in the display.

Setting the Relay Operation (rELAY)

This menu is used to set up the operation of the relays.

CAUTION

- During setup, the relays do not follow the input and they will remain in the state found prior to entering the Relay menu.

- Relay action
 - Automatic reset only (non-latching)
 - Automatic + manual reset at any time (non-latching)
 - Latching (manual reset only)
 - Latching with Clear (manual reset only after alarm condition has cleared)
 - Relay alternation control (automatic reset only)
 - Sampling (the relay is activated for a user-specified time)
 - Off (relay disabled and Interlock feature enabled)
- Set point
- Reset point
- Fail-safe operation
 - On (enabled)
 - Off (disabled)
- Time delay
 - On delay (0-999.9 seconds)
 - Off delay (0-999.9 seconds)
- Relay action for loss (break) of input (ignore, on, off)

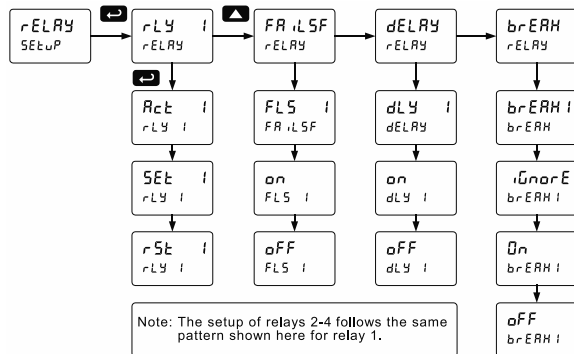

Setting the Relay Action

Operation of the relays is programmed in the *Action* menu. The relays may be set up for any of the following modes of operation:

- Automatic reset (non-latching)
- Automatic + manual reset at any time (non-latching)
- Latching (manual reset only, at any time)
- Latching with Clear (manual reset only after alarm condition has cleared)
- Relay alternation control (automatic reset only)
- Sampling (the relay is activated for a user-specified time)
- Off (relay disabled and Interlock feature enabled)

The following graphic shows relay 1 action setup; relay 2-4 are set up in a similar fashion.

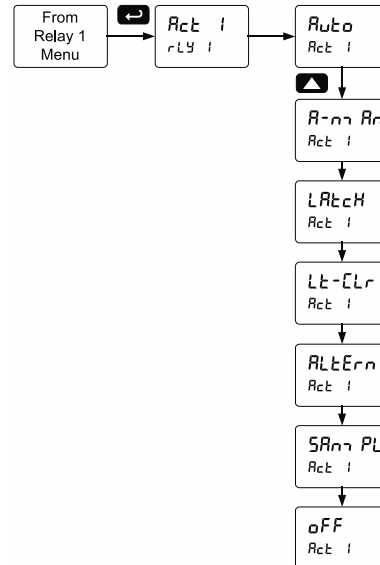

Programming Set and Reset Points

High alarm indication: program set point above reset point.

Low alarm indication: program set point below reset point.

The deadband is determined by the difference between set and reset points. Minimum deadband is one display count. If the set and reset points are programmed with the same value, the relay will reset one count below the set point.

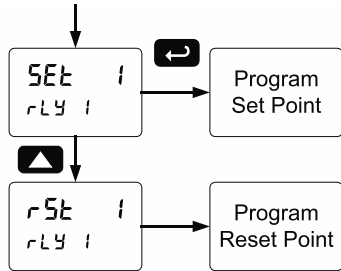

Note: Changes are not saved until the reset point has been accepted.

Setting Fail-Safe Operation

In fail-safe mode of operation, the relay coil is energized when the process variable is within safe limits and the relay coil is de-energized when the alarm condition exists. The fail-safe operation is set independently for each relay. Select **on** to enable or select **oFF** to disable fail-safe operation.

Programming Time Delay

The *On* and *Off* time delays may be programmed for each relay between 0 and 999.9 seconds. The relays will transfer only after the condition has been maintained for the corresponding time delay.

The *On* time delay is associated with the set point.

The *Off* time delay is associated with the reset point.

Relay Action for Loss of Input (Input Break)

Each relay may be programmed to go to one of the following conditions when the meter detects the loss of the input signal:

1. Turn *On* (Go to alarm condition)
2. Turn *Off* (Go to non-alarm condition)
3. Ignore (Processed as an upscale condition)

Relay and Alarm Operation Diagrams

The following graphs illustrate the operation of the relays, status LEDs, and ACK button.

High Alarm Operation (Set > Reset)

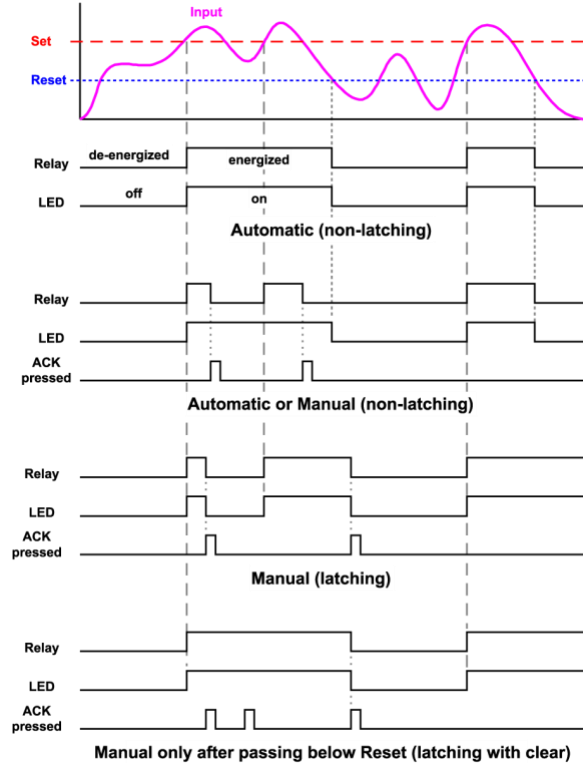

Manual only after passing below Reset (latching with clear)

For Manual reset mode, ACK can be pressed anytime to turn "off" relay. To detect a new alarm condition, the signal must go below the set point, and then go above it.

Low Alarm Operation (Set < Reset)

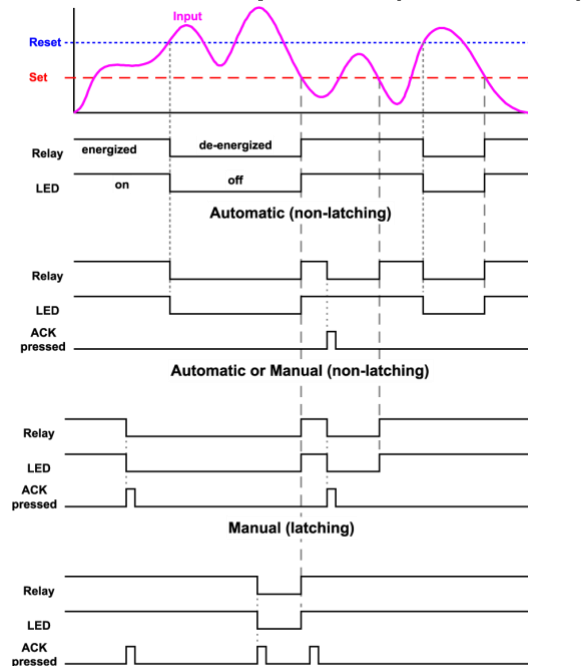

Manual only after passing above Reset (latching with clear)

For Manual reset mode, ACK can be pressed anytime to turn "off" relay. For relay to turn back "on", signal must go above set point and then go below it.

High Alarm with Fail-Safe Operation (Set > Reset)

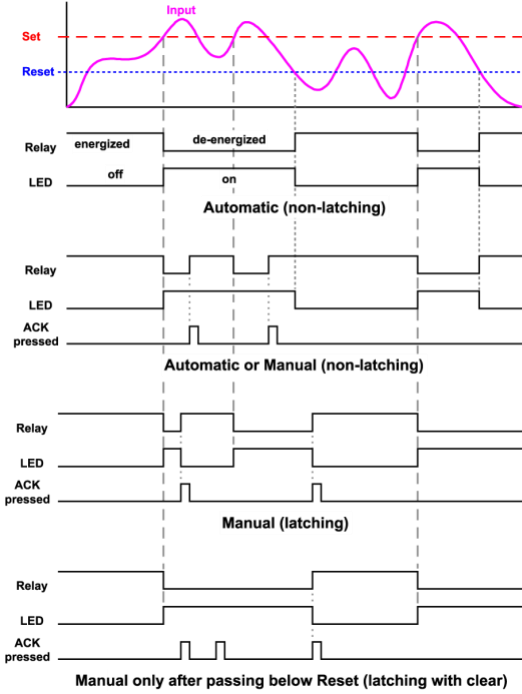

Note: Relay coil is energized in non-alarm condition. In case of power failure, relay will go to alarm state.

Low Alarm with Fail-Safe Operation (Set < Reset)

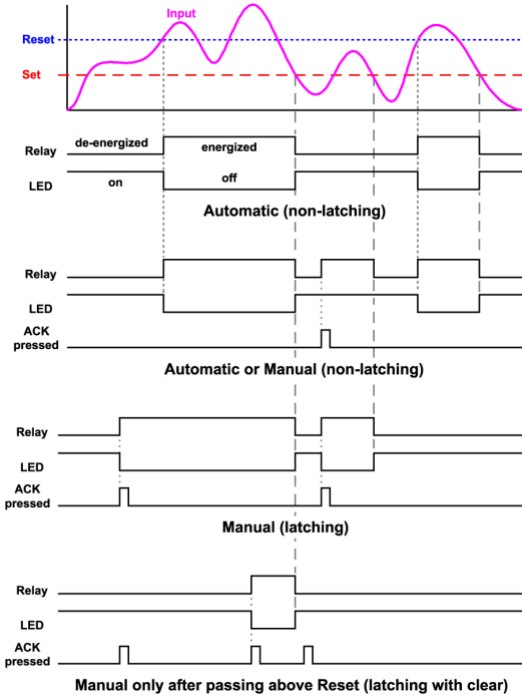

Note: Relay coil is energized in non-alarm condition. In case of power failure, relay will go to alarm state.

Relay Sampling Operation

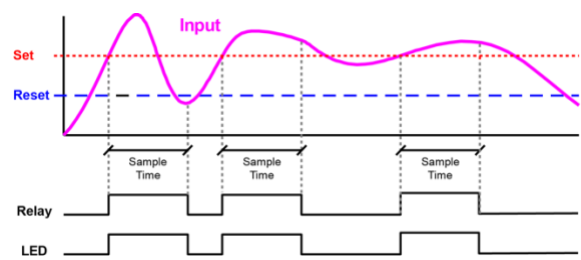

When the signal crosses the set point, the relay trips and the sample time starts. After the sample time has elapsed, the relay resets. The cycle repeats every time the set point is crossed, going up for high alarms and going down for low alarms.

The sample time can be programmed between 0.1 and 5999.9 seconds.

Signal Loss or Input Break Relay Operation

The following graph shows the input break relay operation for a high alarm relay.

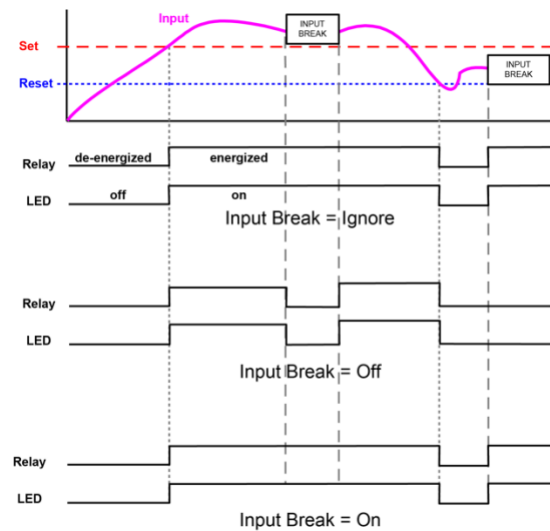

When the meter detects a break in the input, the relay will go to one of the following selected actions:

1. Turn On (Go to alarm condition)
2. Turn Off (Go to non-alarm condition)
3. Ignore (Processed as an upscale condition)

Time Delay Operation

The following graphs show the operation of the time delay function.

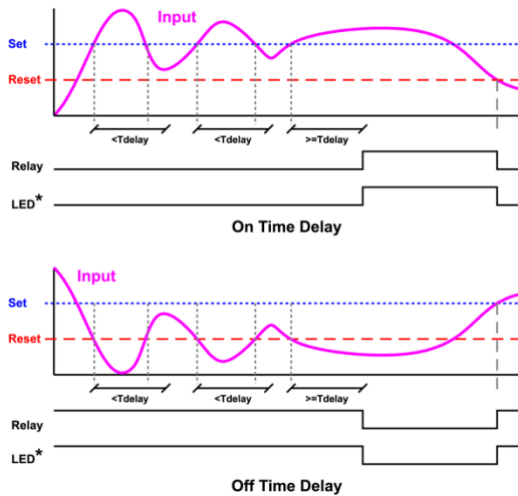

When the signal crosses the set point, the *On* time delay timer starts and the relay trips when the time delay has elapsed. If the signal drops below the set point (high alarm) before the time delay has elapsed, the *On* time delay timer resets and the relay does not change state. The same principle applies to the *Off* time delay.

Note: If “Automatic or Manual (R-n-rn)” reset mode is selected, the LED follows the reset point and not the relay state when the relay is acknowledged.

Relay Operation Details

Overview

The four-relays option for the meter expands its usefulness beyond simple indication to provide users with alarm and control functions. Typical applications include high or low temperature alarms, control applications such as simple on/off temperature control. There are four basic ways the relays can be used:

1. High and Low Alarms with Latching or Non-Latching Relays
2. Simple On/Off Control with 100% Adjustable Deadband
3. Sampling (Based on Time)
4. Relay Alternation Control

Relays Auto Initialization

When power is applied to the meter, the front panel LEDs and alarm relays will reflect the state of the input to the meter. The following table indicates how the alarm LEDs and relays will react on power-up based on the set and reset points:

Alarm #	HI or LO Alarm	Set Point	Reset Point	Power-Up Reading	Relay & LED
1	HI	1000	500	499	Off
2	LO	700	900	499	On
3	LO	250	400	499	Off
4	HI	450	200	499	On

Fail-Safe Operation

The following table indicates how the relays behave based on the fail-safe selection for each relay:

Fail-Safe Selection	Non-Alarm State		Alarm State		Power Failure
	NO	NC	NO	NC	
Off	Open	Closed	Closed	Open	Relays go to non-alarm state
On	Closed	Open	Open	Closed	Relays go to alarm state

Note: NO = Normally Open, NC = Normally Closed. This refers to the condition of the relay contacts when the power to the meter is off.

Front Panel LEDs

The alarm status LEDs on the front panel are available on all meters, even those without relays installed, and provide status indication for the following:

LED	Status
1	Alarm 1
2	Alarm 2
3	Alarm 3
4	Alarm 4

The meter is supplied with four alarm points that include front panel LEDs to indicate alarm conditions. This standard feature is particularly useful for alarm applications that require visual-only indication. The LEDs are controlled by the set and reset points programmed by the user. When the display reaches a set point for a high or low alarm, the corresponding alarm LED will turn on. When the display returns to the reset point the LED will go off. The front panel LEDs respond differently for latching and non-latching relays.

For non-latching relays, the LED is always off during normal condition and always on during alarm condition, regardless of the state of the relay (e.g. Relay acknowledged after alarm condition).

For latching relays, the alarm LEDs reflect the status of the relays, regardless of the alarm condition. The following tables illustrate how the alarm LEDs function in relation to the relays and the acknowledge button (Default: F3 key assigned to ACK).

Latching and Non-Latching Relay Operation

The relays can be set up for latching (manual reset) or non-latching (automatic reset) operation.

Relay terminology for following tables	
Terminology	Relay Condition
On	Alarm (Tripped)
Off	Normal (Reset)
Ack	Acknowledged

The On and Off terminology does not refer to the status of the relay's coil, which depends on the fail-safe mode selected.

WARNING

- In latching relay mode, if Fail-Safe is off, latched relays will reset (unlatch) when power is cycled.

Non-Latching Relay (Αυτόμα)

In this application, the meter is set up for automatic reset (non-latching relay). Acknowledging the alarm while it is still present has no effect on either the LED or the relay. When the alarm finally goes away, the relay automatically resets and the LED also goes off.

Automatic reset only		
Condition	LED	Relay
Normal	Off	Off
Alarm	On	On
Ack (No effect)	On	On
Normal	Off	Off

Non-Latching Relay with Manual Reset (Α-ηχη)

In this application, the meter is set up for automatic and manual reset at any time (non-latching relay). The LED and the relay automatically reset when the meter returns to the normal condition.

In addition, the relay can be manually reset while the alarm condition still exists, but the LED will stay on until the meter returns to the normal condition.

Automatic + manual reset at any time		
Condition	LED	Relay
Normal	Off	Off
Alarm	On	On
Normal	Off	Off
Next Alarm	On	On
Ack	On	Off
Normal	Off	Off

Latching Relay (Λήψη)

In this application, the meter is set up for manual reset at any time. Acknowledging the alarm even if the alarm condition is still present resets the relay and turns off the LED.

Manual reset any time		
Condition	LED	Relay
Normal	Off	Off
Alarm	On	On
Ack	Off	Off

Latching Relay with Clear (Lr - CLR)

In this application, the meter is set up for manual reset only after the signal passes the reset point (alarm condition has cleared). Acknowledging the alarm while it is still present has no effect on either the LED or the relay. When the alarm is acknowledged after it returns to the normal state, the LED and the relay go off. Notice that the LED remains on, even after the meter returns to the normal condition. This is because, for latching relays, the alarm LED reflects the status of the relay, regardless of the alarm condition.

Manual reset only after alarm condition has cleared		
Condition	LED	Relay
Normal	Off	Off
Alarm	On	On
Ack (No effect)	On	On
Normal	On	On
Ack	Off	Off

Light / Horn / Button Accessories



Add visible and audible ways to indicate alarm conditions on any Helios meter with the [MOD-PD2LH](#) Light / Horn / Button accessories. The light with built-in 85 dB horn, and button come mounted and wired to the Helios. An external 24 VDC power supply ([PDA1024-01](#)) is required to power the Light / Horn. Meter and accessories are ordered as separate items. See *Ordering Information* on page 6.

Acknowledging Relays

There are three ways to acknowledge relays programmed for manual reset:

1. Via the programmable front panel function keys F1-F3 (Example: F3 assigned to ACK).

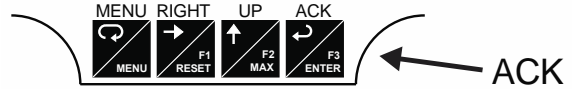

2. Remotely via a normally open pushbutton wired to the F4 terminal.

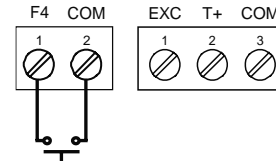

3. Remotely via a normally open push button wired to one of the digital inputs and the +5 V terminal on the digital I/O connections.

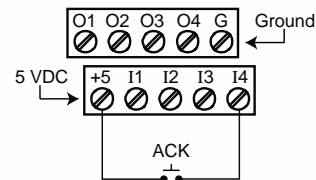

When the ACK button or the assigned digital input is closed, all relays programmed for manual reset are acknowledged.

Acknowledging Relays with Remote Control Station

Relays may be remotely acknowledged by connecting the [PDA2361-A](#) to either the F4 terminal or a digital input as described above.



Setting Up the Interlock Relay (Force On) Feature

Relays 1-4 can be set up as interlock relays. To set up the relays for the interlock feature:

1. Access the *Setup – Relay – Action* menu and set the action to off.

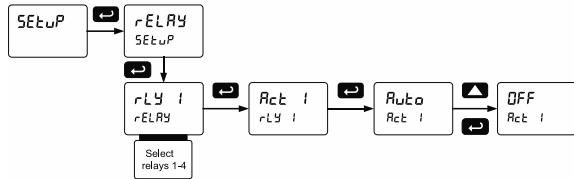

2. In the *Advanced features – User* menu program any of the digital inputs to *Force On* any of the internal relays (1-4).

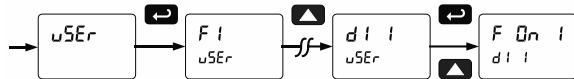

3. Connect a switch or dry contact between the +5V terminal and the corresponding digital input (dl-1 to dl-4) terminal.

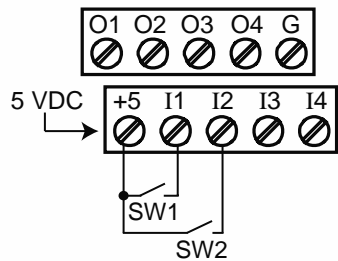

Interlock Relay Operation Example

Relays 1 & 2 are configured to energize (their front panel LEDs are steady on) when SW1 & SW2 switches (above) are closed. If the contacts to these digital inputs are opened, the corresponding front panel LEDs flash indicating this condition. The processes being controlled by the interlock relay will stop, and will re-start only after the interlock relay is re-activated by the digital inputs (switches).

Note: If multiple digital inputs are assigned to the same relay, then the corresponding logic is (AND) – i.e. both switches must be closed to activate the relay.

IMPORTANT

- If the digital inputs are assigned to the *Interlock Function*, then they cannot be used to program the meter remotely.

Scaling the 4-20 mA Analog Output (Rout)

The 4-20 mA analog output can be scaled to provide a 4-20 mA signal for any display range selected.

No equipment is needed to scale the analog output; simply program the display values to the corresponding mA output signal.

The *Analog Output* menu is used to program the 4-20 mA output based on display values.

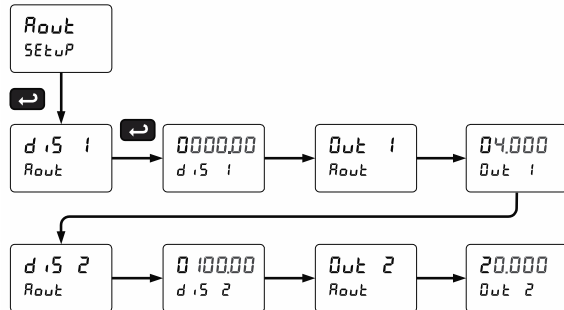

Note: During the analog output scaling, the display value is always indicated with a decimal point regardless of the decimal point selection for the temperature display.

For instructions on how to program numeric values see *Setting Numeric Values*, page 24.

Reset Menu (rESEt)

The *Reset* menu is used to reset the maximum or minimum reading (peak or valley) reached by the process; both may be reset at the same time by selecting “reset high & low” (rSEt HL).

Manual Control Menu (Control)

The *Manual Control* menu is used to control the 4-20 mA analog output and the relays manually, ignoring the input. Each relay and analog output can be programmed independently for manual control. Selecting automatic control sets all relays and analog output for automatic operation.

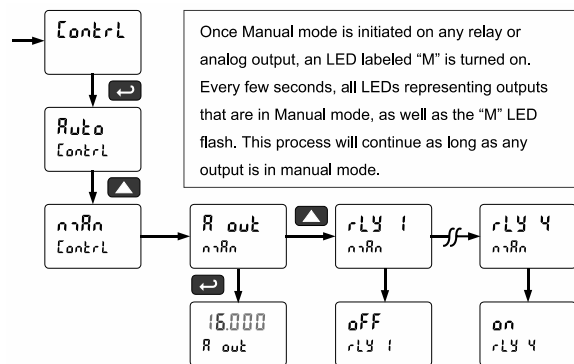

Setting Up the Password (PR55)

The *Password* menu is used for programming three levels of security to prevent unauthorized changes to the programmed parameter settings.

Pass 1: Allows use of function keys and digital inputs
 Pass 2: Allows use of function keys, digital inputs and editing set/reset points
 Pass 3: Restricts all programming, function keys, and digital inputs.

Protecting or Locking the Meter

Enter the *Password* menu and program a six-digit password.

For instructions on how to program numeric values see *Setting Numeric Values*, page 24.

Making Changes to a Password Protected Meter

If the meter is password protected, the meter will display the message *L o c k* (*Locked*) when the Menu button is pressed. Press the Enter button while the message is being displayed and enter the correct password to gain access to the menu.

Note: After exiting the programming mode, the meter returns to its password protected condition

Disabling Password Protection

To disable the password protection, access the *Password* menu and enter the correct password twice, as shown below. The meter is now unprotected until a new password is entered.

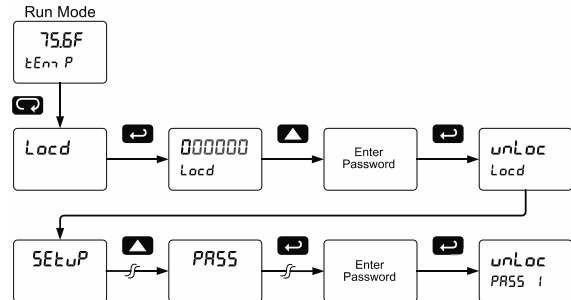

If the correct six-digit password is entered, the meter displays the message *unL o c k* (*unlocked*) and the protection is disabled until a new password is programmed.

If the password entered is incorrect, the meter displays the message *L o c k* (*Locked*) for about two seconds, and then it returns to Run Mode. To try again, press Enter while the *Locked* message is displayed.

Did you forget the password?

The password may be disabled by entering a master password once. If you are authorized to make changes, enter the master password 508655 to unlock the meter.

Advanced Features Menu

To simplify the setup process, functions not needed for most applications are located in the *Advanced Features* menu.

Press and hold the Menu button for three seconds to access the advanced features of the meter.

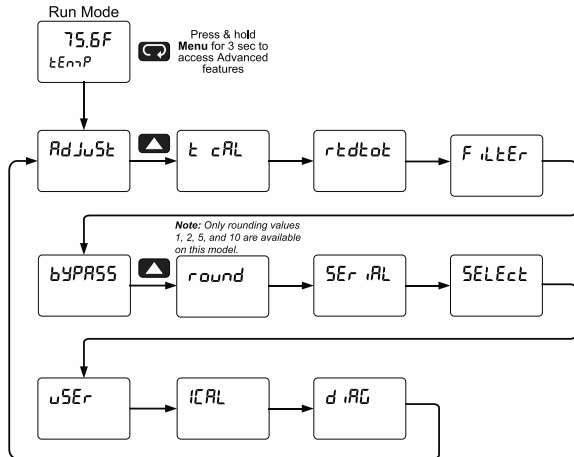

Advanced Features Menu & Display Messages

The following table shows the functions and messages of the *Advanced Features* menu in the order they appear in the menu.

Display	Parameter	Action/Setting
RdJusE	Adjust	Set adjust value to offset temperature reading
t cRL	T Cal	Enter temperature calibration menu
t Lo	T Low	Apply the low temperature input (e.g. 32°F)
t Hi	T High	Apply the high temperature input (e.g. 1000°F)
rtdtot	RTD Total	Set the number of RTDs connected in parallel to obtain average temperature
F ilLEr	Filter	Set noise filter value
bYPR55	Bypass	Set filter bypass value
round	Round	Set the rounding value for display variables
SEr iRL	Serial	Set serial communication parameters
SlRi id	Slave ID	Set slave ID or meter address
bRud	Baud rate	Select baud rate
tr dLY	Transmit delay	Set transmit delay for serial communication
PRr iLY	Parity	Select parity Even, Odd, or None with 1 or 2 stop bits
t -bLY	Time byte	Set byte-to-byte timeout

Display	Parameter	Action/Setting
SELEcE	Select	Enter the Select menu
RoutPr	Analog output programming	Program analog output parameters
Source	Source	Select source for the 4-20 mA output
o-rrng	Overrange	Program mA output for display overrange
u-rrng	Underrange	Program mA output for display underrange
brERH	Input break	Set analog output value if input break is detected
max	Maximum	Program maximum mA output allowed
min	Minimum	Program minimum mA output allowed
iCRL	Calibrate	Calibrate 4-20 mA output (internal reference source used for scaling the output)
4 mA	4 mA output	Enter mA output value read by milliamp meter with at least 0.001 mA resolution
20 mA	20 mA output	Enter mA output value read by milliamp meter with at least 0.001 mA resolution
uSEr	User I/O	Assign function keys and digital I/O
F 1	F1 function key	Assign F1 function key
F2	F2 function key	Assign F2 function key
F3	F3 function key	Assign F3 function key
F4	F4 function	Assign F4 function (digital input)
d i 1	Digital input 1	Assign digital input 1 – 4
d o 1	Digital output 1	Assign digital output 1 – 4
iCRL	Internal temp calibration	Enter internal temperature calibration (used for factory calibration only)
measEF	Measured temp reference	Enter the measured reference temperature in degrees Celsius (e.g. 25.0)
0 mV	0 mV	Apply 0.000 mV input Internal Calibration
100 mV	100 mV	Apply 100.000 mV input
d iRG	Diagnostics	Display parameter settings
LEd t	LED test	Test all LEDs (press menu to exit test)
info	Information	Display software number and version
ER5E	Erase	Erase MeterView Pro software stored in meter's memory

Offset Adjust (Rd Ju5t)

This parameter allows the user to select an offset adjustment to the temperature being displayed. Offset adjustment values can be either positive or negative and can be any number within $\pm 50.0^{\circ}\text{F}$ ($\pm 27.8^{\circ}\text{C}$). The offset adjustment value is programmed through the *Adjust* menu.

The offset adjustment feature can be useful to compensate for errors due to thermocouple junctions or excessive lead wire resistance in RTDs.

Note: The offset adjustment value is reset to zero when the type of temperature sensor is changed (i.e. TC type or RTD curve). Celsius/Fahrenheit conversion is automatic.

Recalibration of the Meter (t RL)

The *Calibration* (t RL) menu is used to **recalibrate** the thermocouple and RTD inputs.

- There is **no need to recalibrate** the meter when first received from the factory. Simply select the input type, $^{\circ}\text{F}$ or $^{\circ}\text{C}$, and decimal point.
- The meter is **factory calibrated** prior to shipment to read temperature in degrees Fahrenheit with calibration equipment that is certified to NIST standards.
- Check calibration of the meter at least every 12 months.

Allow at least 30 minutes warm-up time before performing recalibration procedure to ensure specified accuracy.

Recommended Calibration Points

To recalibrate the meter, it is recommended to use the Fahrenheit scale; this will give a greater degree of accuracy to the calibration. The scale can be changed to the Celsius scale after calibration is completed. The meter will display temperature accurately in any scale. The following table shows the recommended low and high calibration points for all types.

Type of input	Input 1 (Low)	Input 2 (High)	Check (Middle)
Type J	32°F	1184°F	600°F
Type K	32°F	1895°F	960°F
Type T	32°F	698°F	360°F
Type E	32°F	1652°F	800°F
Type R	32°F	3110°F	1500°F
Type S	32°F	3110°F	1500°F
Type B	32°F	3110°F	1500°F
Type N	32°F	1472°F	700°F
Type C	500°F	3650°F	1800°F
10 Ω Cu RTD	32°F 9.035 Ω	450°F 18.032 Ω	200°F 12.639 Ω
100 Ω Pt RTD (0.00385)	32°F 100 Ω	1148°F 320.12 Ω	590°F 215.61 Ω
100 Ω Pt RTD (0.00392)	32°F 100 Ω	1148°F 324.49 Ω	590°F 217.89 Ω
120 Ω Ni RTD	32°F 120 Ω	410°F 315.31 Ω	221°F 205.22 Ω
1000 Ω Pt RTD (0.00385)	32°F 1000 Ω	900°F 2750.4 Ω	450°F 1876.5 Ω
1000 Ω Pt RTD (0.00392)	32°F 1000 Ω	900°F 2785.1 Ω	450°F 1893.7 Ω

Recalibration Procedure

1. Connect signal to the meter using the appropriate wire (e.g. type J thermocouple wire to recalibrate type J input). See
2. *Signal Connections* on page 16.
3. Set up the meter to accept the selected input (e.g. type J T/C). See *Setting Up the Meter* (5EturP) on page 25.
4. Set up the meter to display temperature in degrees Fahrenheit.
5. Apply signal corresponding to input 1 (32°F) and program the display to read 32.0.
6. Apply signal corresponding to input 2 (1184°F for type J) and program the display accordingly.
7. After the meter accepts input 2, the display returns to reading mode. This completes the recalibration procedure for the selected input.

Noise Filter (F RLtEr)

The noise filter is available for unusually noisy signals that cause an unstable process variable display. The noise filter averages the input signal over a certain period. The filter level determines the length of time over which the signal is averaged. The filter level can be set between 2 and 199. The higher the filter level, the longer the averaging time and so the longer it takes the display to settle to its final value. Setting the filter level to zero disables the filter function.

Noise Filter Bypass (bYPASS)

The noise filter bypass changes the behavior of the meter so that small variations in the signal are filtered out but large abrupt changes in the input signal are displayed immediately. The bypass value determines the minimum amount of signal change to be displayed immediately. All signal changes smaller than the bypass value are filtered or averaged by the meter. The noise filter bypass may be set between 0.1 and 99.9% of full scale.

Rounding Feature (rOund)

The rounding feature is used to give the user a steadier display with fluctuating signals. Rounding is used in addition to the filter function. Rounding causes the display to round to the nearest value according to the rounding selected. Valid settings for this meter are 1, 2, 5, and 10 (only).

Modbus RTU Serial Communications (SEr iRL)

The meter is equipped with serial communications capability as a standard feature using the Modbus RTU Serial Communication Protocol.

The meter may be connected to a PC for initial configuration via the onboard USB connection. For ongoing digital communications with a computer or other data terminal equipment, use the RS-485 connection with the appropriate serial converter; see *Ordering Information* on page 6 for details.

CAUTION

- **DO NOT** connect any equipment to the RJ45 M-LINK connector. Otherwise damage will occur to the equipment and the meter.
- **DO NOT** disconnect the RJ45 connector located to the left of the power terminal block. Doing so will disable the on-board digital I/O, and the RS-485 serial communications.

Notes:

1. More detailed instructions are provided with each optional serial communications adapter.
2. Refer to the Helios Modbus Register Tables located at www.predig.com for details.

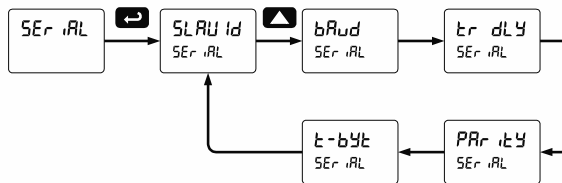

When using more than one meter in a multi-drop mode, each meter must have its own unique Slave ID or meter address. The ID or address may be programmed between 1 and 247. The transmit delay may be set between 0 and 199 ms. The parity can be set to even, odd, or none with 1 or 2 stop bits.

Select Menu (SELEct)

The *Select* menu is used to program the analog output parameters. There are no other selections for this model.

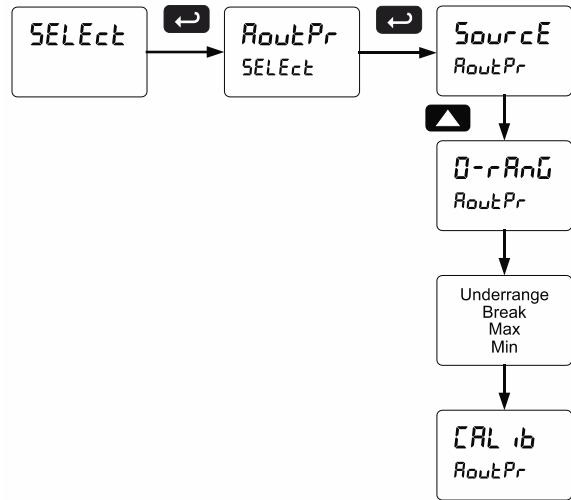

Analog Output Programming (RoutPr)

The *Analog Output Programming* menu is used to program the behavior of the 4-20 mA output. The following parameters and functions are programmed in this menu:

1. Source: Source for generating the 4-20 mA output (e.g. PV - temperature)
2. Overrange: Analog output value with display in overrange condition
3. Underrange: Analog output value with display in underrange condition
4. Break: Analog output value when input break is detected
5. Max: Maximum analog output value allowed regardless of input
6. Min: Minimum analog output value allowed regardless of input
7. Calibrate: Calibrate the internal 4-20 mA source reference used to scale the 4-20 mA output

Analog Output Source

The source for generating the 4-20 mA output may be assigned to the process variable, maximum or minimum value reached by the process, one of the set points, or the Modbus PV input.

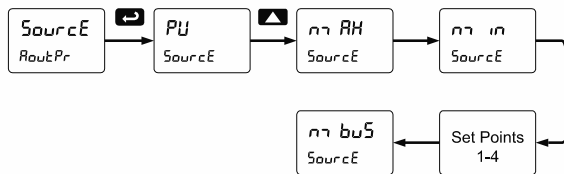

Analog Output Calibration

To perform the analog output calibration, it is recommended to use a milliamp meter with a resolution of at least 0.1 μ A to measure the output current. The values saved internally during this procedure are used for scaling the 4-20 mA output in the *Setup* menu.

Analog Output Calibration Procedure

1. Wire the PD2-7000 4-20 mA output to a current loop that includes a power supply (internal or external 12 to 24 VDC), and the mA input on the digital meter. See *Figure 26. 4-20 mA Output Connections* on page 19 for details.
2. Turn on all devices. Allow for a 15 to 30 minute warm-up.
3. Go to the Advanced Features menu, and navigate to the Analog Output Programming (RoutPr)/Calibration (LR, b) menu and press **Enter**.
4. The display will show 4 mA. The PD2-7000 mA output should now be close to 4 mA. Press **Enter** and the display will show 04.000. Enter the actual value read by the digital mA meter and press **Enter**.
5. The display will show 20 mA. The PD2-7000 mA output should now be close to 20 mA. Press **Enter** and the display will show 20.000. Enter the actual value read by the digital mA meter and press **Enter**.
6. The meter will now calculate the calibration factors and store them.
7. Press **Menu** to exit and return to Run mode.

Programmable Function Keys User Menu (uSEr)

The *User* menu allows the user to assign the front programming buttons function keys F1, F2, and F3, the digital input F4 (located on the input signal connector), and four digital inputs (located on the digital I/O connector) to access most of the menus or to activate certain functions immediately (e.g. reset max & min, hold relay states, etc.). This allows the meter to be greatly customized for use in specialized applications.

The four digital outputs can be assigned to a number of actions and functions executed by the meter (i.e. alarms, relay acknowledgement, reset max, min, or max & min, tare, and reset tare). The digital outputs can be used to trigger external alarms or lights to indicate these specific events.

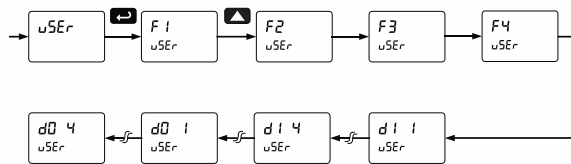

Function Keys & Digital I/O Available Settings

Refer to the following table for descriptions of each available function key or digital I/O setting.

Display	Description
rSt Hi	Reset the stored maximum display value
rSt Lo	Reset the stored minimum display value
rSt HL	Reset the stored maximum & minimum display values
tRrE	Capture tare and zero the display
rSt tr	Reset captured tare and resume normal operation
rELRY	Directly access the relay menu
SEt i*	Directly access the set point menu for relay 1 (*through 4)
rLY d	Disable all relays until a button assigned to <i>enable relays (rLY E)</i> is pressed
rLY E	Enable all relays to function as they have been programmed
HoLd	Hold current relay states as they are until a button assigned to <i>enable relays (rLY E)</i> is pressed
d HoLd	Hold the current display value momentarily while the function key or digital input is active. The process value will continue to be calculated in the background.
Ln1 Hi	Display maximum display value on line 1
Ln1 Lo	Display minimum display value on line 1
Ln1 HL	Display maximum & minimum display values on line 1
Ln2 Hi	Display maximum display value on line 2
Ln2 Lo	Display minimum display value on line 2
Ln2 HL	Display maximum & minimum display values on line 2
F On i*	Force relay 1 (*through 4) into the on state. This function is used in conjunction with a digital input to achieve interlock functionality. See page 32 for details about interlock relays.
CoNtRl	Directly access the control menu
d ,SRbL	Disable the selected function key or digital I/O
RcH	Acknowledge all active relays that are in a manual operation mode such as auto-manual or latching
rESEt	Directly access the reset menu
nREnu	Mimic the menu button functionality (digital inputs only)
r uHt	Mimic the right arrow/F1 button functionality (digital inputs only)
uP	Mimic the up arrow/F2 button functionality (digital inputs only)
EnEr	Mimic the enter/F3 button functionality (digital inputs only)
RLn i*	Provide indication when alarm 1 (*through 4) has been triggered (digital outputs only)

Internal Temperature Calibration (ICAL)

The meter is **factory calibrated** prior to shipment to read temperature in degrees Fahrenheit with calibration equipment that is certified to NIST standards.

The Internal Calibration (ICAL) is a function used at the factory to calibrate all the thermocouple and RTD ranges. This procedure should only be used by qualified personnel.

To recalibrate the meter for a specific input and range, refer to *Recalibration of the Meter (ICAL)* on page 37.

Notes:

1. If meter is in operation and it is intended to accept only one input type (e.g. 100 Pt), recalibration of other inputs is not necessary.
2. Allow the meter to warm up for at least 30 minutes before performing the calibration procedure.
3. Use the *Recalibration of the Meter (ICAL)* procedure on page 37.

The *Internal calibration* menu is part of the *Advanced Features* menu and is described in the following pages. This procedure should only be used by qualified personnel.

Note: Most users should not require the use of the Internal Calibration procedure. The T CAL procedure should be used instead of the ICAL procedure.

Thermocouple Input Internal Calibration (ICAL)

1. Set the Type selector switch in the TC position and using copper wire connect a precision mV calibrator to the input.
2. In the *Setup* menu select the input: TC – Type J.
3. Press and hold the Menu button for three seconds to access the advanced features of the meter.
4. Press the Up arrow button to scroll to the *Internal calibration* menu (ICAL) and press Enter.
5. The meter displays either current calibration (REF). Press Enter to start the calibration process.
6. Measure the room temperature in degrees Celsius using a reliable reference, enter the room temperature (e.g. 25.0), and press Enter.
7. The meter displays 0.000, apply an input equal to 0.000 mV and press Enter. The display flashes while accepting the 0 mV input; press Enter again when the display stops flashing.
8. The meter displays 100.000, apply an input equal to 100.000 mV and press Enter. The display flashes while accepting the 100 mV input; press Enter again when the display stops flashing.
9. Apply 0 mV, the meter should read room temperature.

10. This completes the calibration of all the thermocouple ranges.

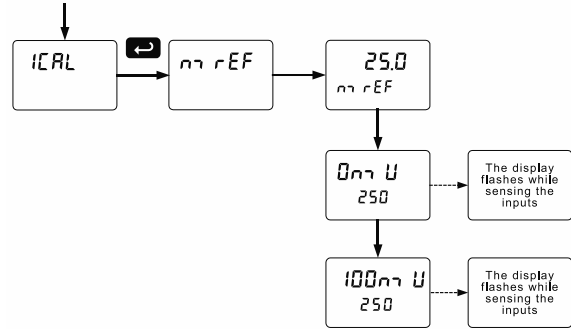

RTD Input Internal Calibration (ICAL)

1. Set the Type selector switch in the RTD position and the Range switch in the 10 position. Using 3 wires connect a precision calibrator resistance output to the meter.
2. In the *Setup* menu select the input: RTD – 100 Pt – A385.
3. Access the *Advanced Features* menu and scroll to the *ICAL* menu and press Enter.
4. The meter displays the message (10 Lo). Apply 9.035 ohm and press Enter. The display flashes for a moment while the meter is accepting the low input signal for the 10-ohm RTD. After the display stops flashing, press Enter again.
5. The meter displays the message (10 Hi). Apply 18.032 ohm and press Enter. The display flashes for a moment while the meter is accepting the high input signal for the 10-ohm RTD. After the display stops flashing, press Enter again.
6. The meter displays the message (100 Lo). **Do NOT press Enter.**
7. Move the Range selector switch to the 100 position. Apply 100 ohm and press Enter. The display flashes for a moment while the meter is accepting the low input signal for the 100-ohm RTD.
8. The meter displays the message (100 Hi). Apply 320.12 ohm and press Enter. The display flashes for a moment while the meter is accepting the high input signal for the 100-ohm RTD.
9. At the end of the calibration process the meter should read 1148.0F with the 320.12-ohm input applied.
10. This completes the calibration of all the RTD ranges.

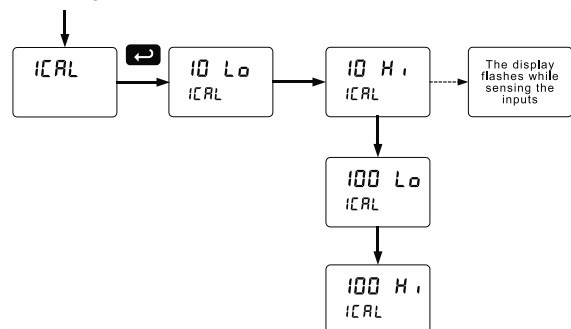

Meter Operation

The meter is capable of accepting a variety of thermocouples and RTDs.

The dual-line display can be customized by the user to operate in such a way as to satisfy a specific application. Typically, display line 1 is used for the process variable; while line 2 is used engineering units, custom legend, or set point indication.

Additionally, the meter can be set up to display the thermocouple or RTD input on line 1 and the Modbus input on line 2. The relays and analog output can be programmed to operate from the Modbus PV input.

Button Operation

Button Symbol	Description
	Press to enter or exit Programming Mode, view settings, or exit max/min readings
	Press to reset max/min readings or other parameter/function assigned through the User menu
	Press to display max/min readings or other parameter/function assigned through the User menu
	Press to acknowledge relays or other parameters/function assigned through the User menu

Function Keys Operation

During operation, the programmable function keys operate according to the way they have been programmed in the *Advanced Features – User menu*. See *Programmable Function Keys User Menu (u5Er)* on page 40 for details.

The table above shows the factory default settings for F1, F2, and F3.

Digital Inputs Operation

Five (5) digital inputs, F4, DI-1 to DI-4, come standard on the meter. These digital inputs are programmed identically to function keys F1, F2, and F3. The inputs are triggered with a contact closure to +5 in the case of digital inputs 1-4 or with an active high signal, see *Digital I/O Connections* on page 19 for details. The F4 is triggered with a contact closure to COM or with an active low signal. During operation, digital inputs operate according to the way they are programmed in the *Advanced Features – User menu*. See *Programmable Function Keys User Menu (u5Er)* on page 40 for details.

Maximum/Minimum Readings

The max & min readings (peak & valley) reached by the process can be displayed either continuously or momentary:

1. Display briefly by assigning to the F1-F3 function keys or to the digital inputs in the *User menu*.
2. Display continuously by assigning either display to max/min through the *Display menu*.

Any of the F1-F3 function keys (buttons) and the digital inputs can be programmed to reset the max & min readings. The meters are set at the factory to display the max reading by pressing the Up arrow/F2 button and to use the Right arrow/F1 button to access the *Reset menu*.

To display max reading using function key with factory defaults:

1. Press Up arrow/F2 button to display maximum reading since the last reset/power-up.
2. To reset max/min press Right arrow/F1 button to access the Reset menu. The max & min displays are reset to actual values.
3. Press Menu to exit max/min display reading.

To display max/min readings continuously:

Assign either display to Max (d H i), Min (d L o), or toggle between Max and Min (d H L) every 10 seconds.

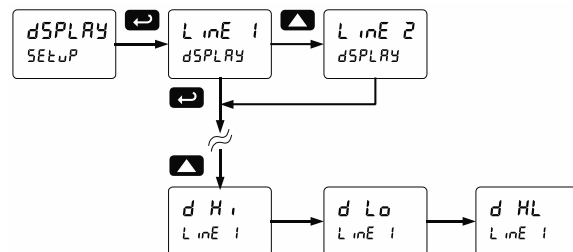

Troubleshooting

The rugged design and the user-friendly interface of the meter should make it unusual for the installer or operator to refer to this section of the manual. However, due to the many features and functions of the meter, it's possible that the setup of the meter does not agree with what an operator expects to see. If the meter is not working as expected, refer to the *Diagnostics* menu and recommendations below.

Diagnostics Menu (d iRÜ)

The *Diagnostics* menu is located in the *Advanced Features* menu, to access *Diagnostics* menu see *Advanced Features Menu* on page 36.

This menu allows the user to test the functionality of all the meter LEDs, check the meter's software and version information, and erase the MeterView Pro software installation files from the meter. Press the Enter button to view the settings and the Menu button to exit at any time.

For a description of the diagnostic messages, see *Advanced Features Menu & Display Messages* on page 36.

Testing the Display LEDs

To test all LEDs on the display:

1. Go to the *Diagnostics* menu (d iRÜ) and press Enter button.
2. Press Up arrow button and scroll to *LED Test* menu (LEd t)
3. Press the Enter button to activate the LED Test. The meter will cycle through all digits, decimal points, and relay indicators to enable the operator to check that all LEDs are functioning properly.
4. Press the Enter button again to access the *Information* menu (iNFo) or press the Menu button to return to Run Mode.

Determining Software Version

To determine the software version of a meter:

1. Go to the *Diagnostics* menu (d iRÜ) and press Enter button.
2. Press Up arrow button and scroll to *Information* menu (iNFo).
3. Press Enter to access the software number (SFt) and version (VER) information. Write down the information as it is displayed. Continue pressing Enter until all the information is displayed.
4. The meter returns to Run Mode after displaying all the settings.

Reset Meter to Factory Defaults

When the parameters have been changed in a way that is difficult to determine what's happening, it might be better to start the setup process from the factory defaults.

Instructions to load factory defaults:

1. Enter the *Advanced Features* menu. See *Advanced Features Menu*, page 36.
2. Press Up arrow to go to *Diagnostics* (d iRÜ) menu
3. Press and hold Right arrow for three seconds, press Enter when display flashes rESEt.
Note: If Enter is not pressed within three seconds, the display returns to the *Diagnostics* menu.
4. The meter goes through an initialization sequence (similar as on power-up) and loads the factory default settings.

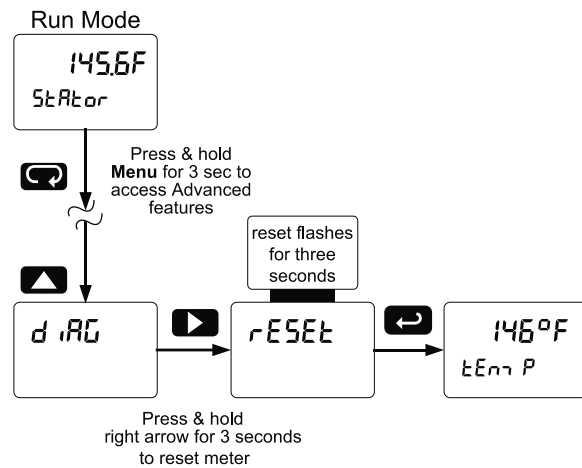

Factory Defaults & User Settings

The following table shows the factory setting for most of the programmable parameters on the meter.

Parameter	Display	Default Setting
Input type	Input	Type J TC
Temp scale	F or C	°F
Adjust	Adjust	0.0
RTD total	rtd tot	1
Filter	Filter	70
Bypass	bypass	0.2
Round	round	1
Decimal point	ddd°	No decimal
Display line 1	Line 1	PV: Temperature
Display line 2	Line 2	Eng units: Temp
Display intensity	d-int	6
Relay 1 action	Rel 1	Automatic
Relay 1 set point	SE 1	100
Relay 1 reset point	RE 1	50
Relay 2 action	Rel 2	Automatic
Relay 2 set point	SE 2	200
Relay 2 reset point	RE 2	150
Relay 3 action	Rel 3	Automatic
Relay 3 set point	SE 3	300
Relay 3 reset point	RE 3	250
Relay 4 action	Rel 4	Automatic
Relay 4 set point	SE 4	400
Relay 4 reset point	RE 4	350
Fail-safe relay 1	FLS 1	Off
Fail-safe relay 2	FLS 2	Off
Fail-safe relay 3	FLS 3	Off
Fail-safe relay 4	FLS 4	Off
On delay relay 1	On 1	0.0 sec
Off delay relay 1	OFF 1	0.0 sec
On delay relay 2	On 2	0.0 sec
Off delay relay 2	OFF 2	0.0 sec
On delay relay 3	On 3	0.0 sec
Off delay relay 3	OFF 3	0.0 sec
On delay relay 4	On 4	0.0 sec

Parameter	Display	Default Setting
Off delay relay 4	OFF 4	0.0 sec
Input break relay 1	Input E	Ignore
Input break relay 2	Input E	Ignore
Input break relay 3	Input E	Ignore
Input break relay 4	Input E	Ignore
Display 1 analog out	d 1	0.0
Output 1 value	Out 1	4.000 mA
Display 2 analog out	d 2	2000.0
Output 2 value	Out 2	20.000 mA
Source analog output	Source E	Process Variable
Overrange output	Over	21.000 mA
Underrange output	Under	3.000 mA
Input break output	br E	1.000 mA
Maximum output	max	23.000 mA
Minimum output	min	1.000 mA
Slave ID	Slave ID	247
Baud rate	baud	9600
Transmit delay	tr dly	10 ms
Parity	Parity	Even
Byte-to-byte timeout	b-byt	010 (0.1 sec)
F1 function key	F 1	Reset max & min
F2 function key	F 2	Line 1: Max (Hi)
F3 function key	F 3	Acknowledge relays
F4 function	F 4	Acknowledge relays
Digital input 1	d i 1	Menu
Digital input 2	d i 2	Right arrow
Digital input 3	d i 3	Up arrow
Digital input 4	d i 4	Enter
Digital output 1	d o 1	Alarm 1
Digital output 2	d o 2	Alarm 2
Digital output 3	d o 3	Alarm 3
Digital output 4	d o 4	Alarm 4
Password 1	PR55 1	000000 (unlocked)
Password 2	PR55 2	000000 (unlocked)
Password 3	PR55 3	000000 (unlocked)

Troubleshooting Tips

This meter is a highly sophisticated instrument with an extensive list of features and capabilities. If the programming buttons are used to program the meter, it may be a difficult task to keep everything straight. That is why we strongly recommend the use of the free [MeterView Pro](#) software for all programming activities. A cable is provided with the meter for programming with MeterView Pro software.

If you have programmed the meter with the programming buttons and it is not working as intended, try re-programming the meter using MeterView Pro software.

Symptom	Check/Action
No display at all	Check power at power connector
Not able to change setup or programming, LoCd is displayed	Meter is password-protected, enter correct six-digit password to unlock or Master Password of 508655.
Meter displays error message during calibration (Error)	Check: 1. Signal connections 2. Type and range selector switches 3. Input selected in <i>Setup</i> menu
Meter displays 1. 99999 2. -9999	Check: 1. Input selected in <i>Setup</i> menu 2. Corresponding signal at Signal connector
Display is unstable	Check: 1. Input signal stability and value 2. Filter and bypass values (increase)
Display response is too slow	Check filter and bypass values
Display reading is not accurate	Check: 1. TC wire type 2. Input selection in <i>Setup</i> menu
Display does not respond to input changes, reading a fixed number	Check: 1. Display assignment, it might be displaying max, min, or set point.
Display alternates between 1. H i and a number 2. Lo and a number	Press Menu to exit max/min display readings.
Relay operation is reversed	Check: 1. Fail-safe in <i>Setup</i> menu 2. Wiring of relay contacts
Relay and status LED do not respond to signal	Check: 1. Relay action in <i>Setup</i> menu 2. Set and reset points
Flashing relay status LEDs	Relays in manual control mode or relay interlock switches opened.
Meter not communicating with application programs	Check: 1. Serial adapter and cable 2. Serial settings 3. Meter address and baud rate
If the display locks up or the meter does not respond at all	Cycle the power to reboot the microprocessor.
Other symptoms not described above	Call Technical Support for assistance.

Note: Certain sequences of events can cause unexpected results. To solve these issues, it is best to start fresh from factory defaults and use the manual as a step by step programming guide, rather than a random approach to programming. To reset the meter to factory defaults, see Reset Meter to Factory Defaults on page 43. In addition, for best results, we recommend using the free MeterView Pro software for all programming needs.

Contact Precision Digital

Technical Support

Call: (800) 610-5239 or (508) 655-7300

Fax: (508) 655-8990

Email: support@predig.com

Sales Support

Call: (800) 343-1001 or (508) 655-7300

Fax: (508) 655-8990

Email: sales@predig.com

Place Orders

Email: orders@predig.com

For the latest version of this manual please visit

www.predig.com

PRECISION DIGITAL CORPORATION

233 South Street • Hopkinton MA 01748 USA

Tel (800) 343-1001 • Fax (508) 655-8990

www.predig.com

