

PROGRAMMABLE RAMP & SOAK PROCESS & TEMPERATURE CONTROLLERS

NOVA PD550 Series

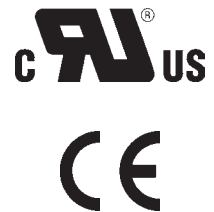

- Thermocouple, RTD, & Process Inputs
- High Accuracy Auto-Tuning PID
- Two Ramp & Soak Programs, 15 segments each
- Universal Power Supply 100-240 VAC
- Up to 3 Relays & 2 Analog Outputs
- Digital Input Program Operation
- RS-485 Serial Communications Option
- Modbus® RTU/ASCII Communications
- Free Operating & Data Logging Software
- IP55 & IP65 Fronts
- 1/16, 3/16, 1/8, 1/4 DIN Sizes
- 3 Year Warranty

PRECISION DIGITAL CORPORATION

**PRECISION
DIGITAL**
www.predig.com

DISPLAYS & PROGRAM OPERATION

Programmable Controllers have dual four-digit LEDs and run set point programs controlled from the main display.

Program Operation

Programs are controlled through the front panel buttons without the need to enter the setup menus to use simple commands.

Main Operation Display

- PV window displays process variable
- SP window displays current set point or **Stop** if no program is running
- Press the **P1** button to run program 1
- Press the **P2** button to run program 2
- Hold the **RST** button to stop a program
- LEDs to indicate the current program, relay status, auto tuning, and program hold
- Press **SET/ENT** button to switch to the next display window



% Output Display
SP window displays the operating level of the control output as % of full scale.

Segment Step
Turn on to immediately move to the next program segment.

Run Status
Displays the remaining running time for the active program segment.

Program Hold
Turn on to put the program on hold and to maintain the current set point.

EASY SETUP & PROGRAMMING

All programming of a Nova Programmable Ramp & Soak Controller is done through the front panel. No switches or jumpers are required.

Front Panel Buttons

- Press the **SET/ENT** button to confirm an entered value. Hold the button for 3 seconds to enter or exit the setup menus or to access the next parameter when in a group.
- Press the **Up** button to increase numerical values or scroll through parameter options and group menus.
- Press the **Down** button to decrease numerical values or scroll through parameter options and group menus.
- Press the **LEFT** button to move to the next digit during numerical value programming.
- Hold the **P1** button for one second to run program 1.
- Hold the **P2** button for one second to run program 2.
- Hold the **RST** button for one second to stop a program.

Note that on some models one button may have several functions, such as Up/P1..

Menus and Groups

Parameters are split into two menus, a program menu and a setup menu. The program menu contains all the parameters needed to construct two 15-segment set point programs. The setup menu contains the groups and parameters to configure the inputs, outputs, alarms, and all other settings for controller operation.

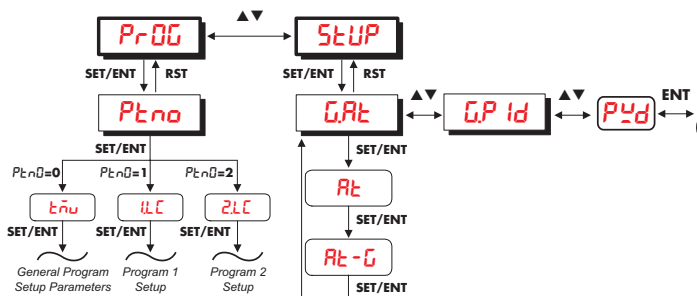

Program Menu

The program menu is arranged in three sections. Group 0 is for general program characteristics, such as time units and set point wait zones. Group 1 and 2 are used to build programs 1 and 2.

PV Display	SP	Group Definition
Pt no	0	General Program Characteristics
Pt no	1	Program Pattern 1 Build Parameters
Pt no	2	Program Pattern 2 Build Parameters

Setup Menu

All general setup parameters are grouped by category for easy parameter navigation.

Button	PV Display	Group Definition
▼	GRt	Auto-Tuning Group
▲▼	GRP id	PID Group
SET/ENT	Pwd	Password
▲▼	GCtL	Control Group
▲▼	G. IS	Inner Signal Group
▲▼	G.do*	Digital Output Group*
▲▼	G. In	Input Group
▲▼	G.out	Output Group
▲▼	GRtñ	Alarm Group
▲▼	G.rEt	Retransmission Group
▲▼	G.Coñ*	Communications Group*

*This group menu appears only on models with the appropriate options.

For a complete list of setup parameters, their functions, and setting options, refer to the PD550 Series Instruction Manual.

Menu Password

A user defined lockout password must be entered to access certain group menus. Enter the password at the prompt when navigating the group menus by pressing the **SET/ENT** button. The default password is 0.

PROCESS & TEMPERATURE INPUTS

Nova Controllers use a single universal input that accepts process and temperature inputs.

Thermocouple: J, K, T, E, R, B, S, L, N, U, W, Platinel II

RTD: Pt100 (0.00385), JPt100 (0.00392)

Process: -10 to 20 mV, 0 to 100 mV
0.4 to 2 V, 1 to 5 V, 0 to 10 V
4 to 20 mA input with a resistor shunt

VERSATILE OPERATION

Powerful standard and optional features such as universal inputs, up to three relays and two analog outputs, two digital inputs, and serial communications make the controller applicable for most process or temperature control applications.

Programmable Relays

All PD550 Series controllers have a standard 3 A Form C (SPDT) relay. Up to two additional 1 A Form A (SPST) relays may be added. All relays can be programmed for numerous control or alarm functions.

- Time-Proportional PID Control
- PV or SP Zone Alarms
- Program Segment or End Alarms
- High, Low, and Deviation Alarms
- Fail-Safe and Standby Alarms
- Alarm Delays and Deadbands

Analog Output Configurations

Up to two analog outputs are available on all PD550 Series controllers. Each analog output can be programmed independently, and numerous output types are selectable.

- 4-20 mA PID Control
- 4-20 mA Retransmitting
- Time-Proportional PID Voltage Pulse
- Transmitter Loop Power Supply

Auto-Tuning PID

A high accuracy auto-tuning function using Fuzzy Logic calculates the PID values for your system with the push of a button, eliminating the need for complex PID calculations and time consuming setup. After several on/off cycles, the PID values will be set automatically.

Gain Adjustment

Adjustments to system control characteristics can be done after auto-tuning with the programmable Gain function. Increasing the Gain will increase accuracy and reduce overshoot. Lowering the Gain will let the system reach the set point faster.

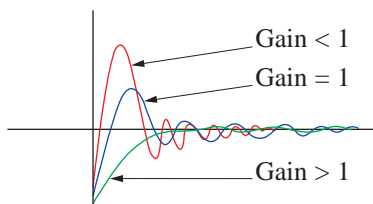

PV Reactions to SP Change Based on Gain

Ramp & Soak Programming

All PD550 Series controllers can store up to two programs of 15 ramp or soak segments each. These programs have a variety of features and are easy to build.

- 2 Programs of 15 Segments Each
- Specific Program Segment Alarms
- Stop, Hold, or Link to Another Program at Program End,
- Repeat Segment Chains
- SP Wait Zone and Time for System Accuracy

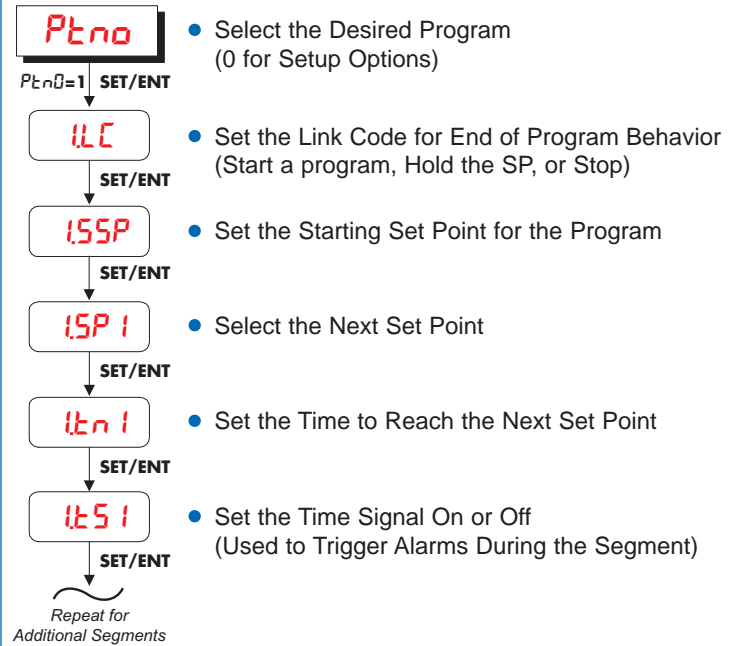

Input Bias Adjustment

Up to five bias points can be used to provide precise offset adjustments at specific input values. The controller will use the offset to create a smooth input value curve leading up to the bias points.

Digital Input Program Operation

Two digital inputs can be added as an optional feature. Digital inputs are activated by closing contacts or low logic levels. The configuration of the two inputs can be used to control or run programs.

DI Selection	Input 1	Input 2	Function
1	off	–	HOLD OFF
	on	–	HOLD ON
	–	off	STEP OFF
	–	on	STEP ON
2	off	off	RESET
	on	–	PROG RUN
	–	off	PROGRAM 1
	–	on	PROGRAM 2

Normally open switches (external excitation not required) or open collector transistor

Inner Signal Zones

Two inner signal zones can be configured to activate when the PV or SP values are within or outside user defined high and low value ranges. Relays and digital outputs can be configured to activate with these inner signal zones.

Digital Outputs

Up to four digital outputs are available as options. These outputs can be configured to activate based on alarms, PV or SP inner signal zones, or set point program behavior (ramp up or down, soak, specific segments, program run or end).

Serial Communications & Adapters

PD550 Series controllers with the serial communications option can be used for data acquisition, Sync master set point control, or Modbus communication (RTU and ASCII). Nova controllers transmit via RS-485. The PDA7485 RS-232 to RS-485 and PDA8485 USB to RS-485 converters are available for use with the Nova Multi-Monitoring software or other PC applications.

Sync Master Set Point Control

PD550 Series controllers with the serial communications option can use Sync set point control. By connecting controllers together using the RS-485 serial communication capability, one controller can control the set point of an entire string.

Sync Master
PD556



RS-485

Use one PD550 Series Ramp & Soak Controller to control the set points of PD540 Series controllers. All PD540 Series slave controllers will copy set point changes throughout the program.



Slave 1
PD548



Slave 2
PD548



Slave 3
PD548



Slave 4
PD548

NOVA PC SOFTWARE

Any Nova Controller with the serial communications option can be configured to interface with the Nova Multi-Monitoring PC software.

- Easy to Set Up and Use
- Connect up to 30 Nova Controllers
- View PV, SP, and Alarm Status Simultaneously
- Build and Run Ramp and Soak Programs
- Log, View, and Save Data in Spreadsheet Files
- Free Download from www.predig.com

Specifications

System Requirements: Windows® 95\98\ME\2000\XP

Communications: An RS-232 to RS-485 or USB to RS-485 converter may be used for communication with a PC and Nova Multi-Monitoring Software.

Number of Units: Up to 30 Nova Controllers

Baud Rate: 9,600 to 19,200 bps

Data Logging: Graph and save data as .hdr format. Each controller saves graphs independently. Data exportable in spreadsheet format.

Logging Interval: 1 second to 24 hours

Simultaneous Monitoring

Simultaneously monitor up to 30 Nova Controllers and view the PV, SP, and alarm status for all connected controllers. The main view screen also displays the basic model numbers of all connected units. Any series of Nova Controllers with the serial communications option may be monitored with this software.



Simultaneously View Up to 30 Nova Controllers

Remotely Operate Programs

Run the two set point programs through a detailed operation screen available for every connected controller. Allows for remote program run, stop, hold, skip, and auto-tuning features.

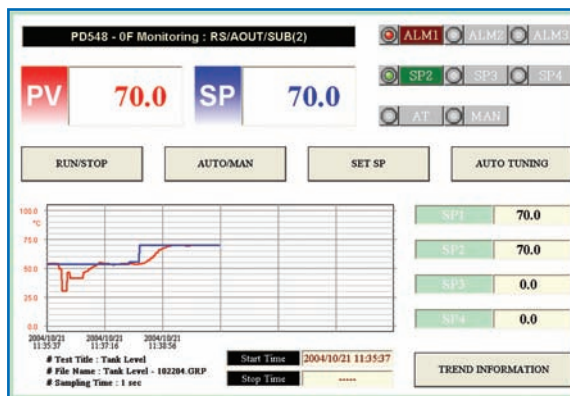

Monitor and Control Ramp & Soak Programs

Data Acquisition

PV and SP data can be logged independently for each unit. This data can be graphed using the Data Viewer for quick and clear analysis. Logged data can be exported into spreadsheet format.

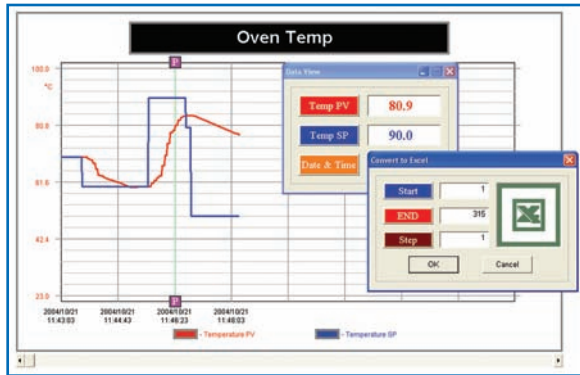

View Logged Data Graphs and Export Data

Program Editing

Set point programs can be quickly and easily built through the Program Editor. These programs can be saved as independent files, downloaded to a controller, and uploaded from a programmed PD550 Series controller.

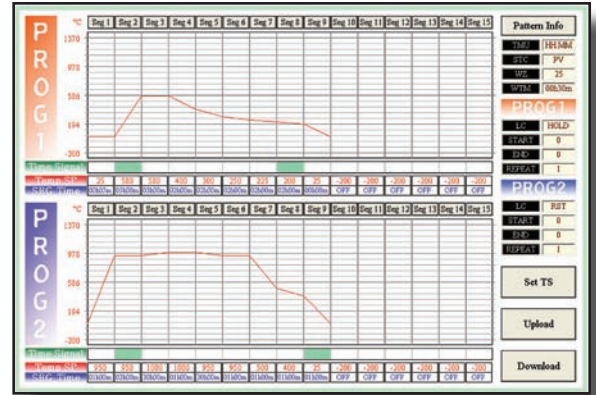

Build and Load Ramp & Soak Programs

Download the Nova Multi-Monitoring Software Free at www.predig.com

CONNECTIONS

: Options

PD550

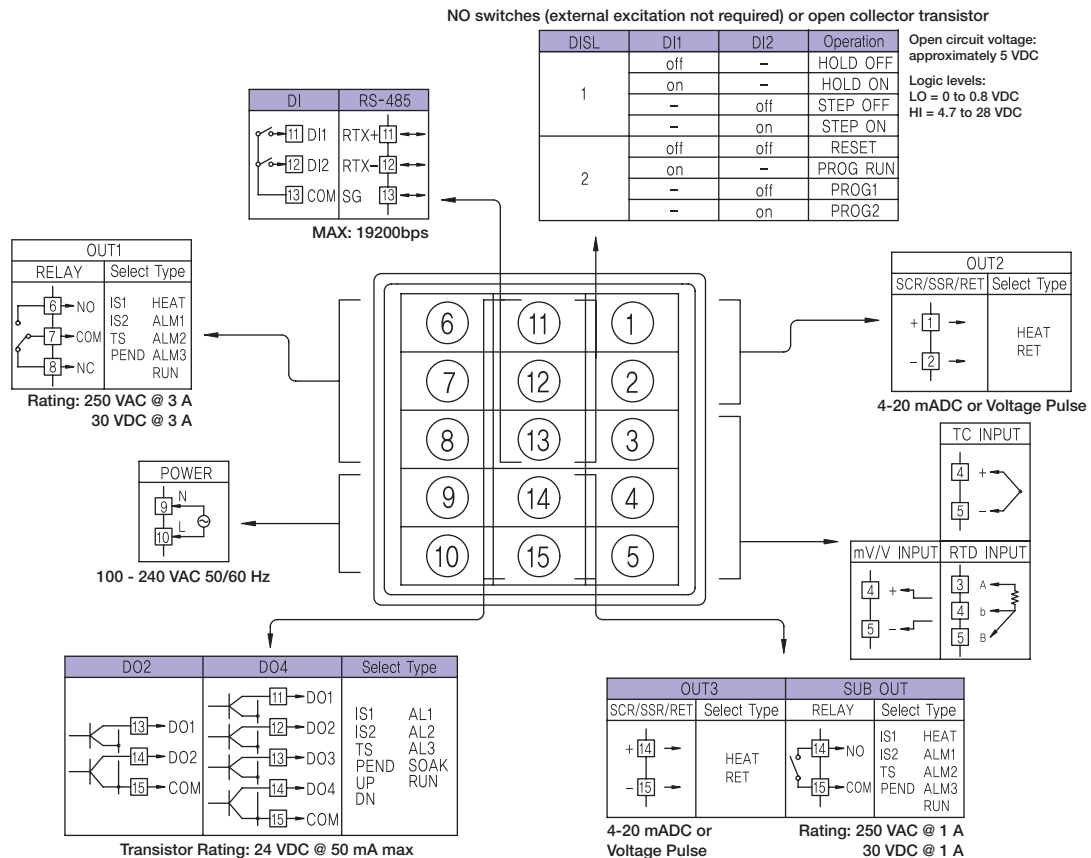

CONNECTIONS

PD554

Options

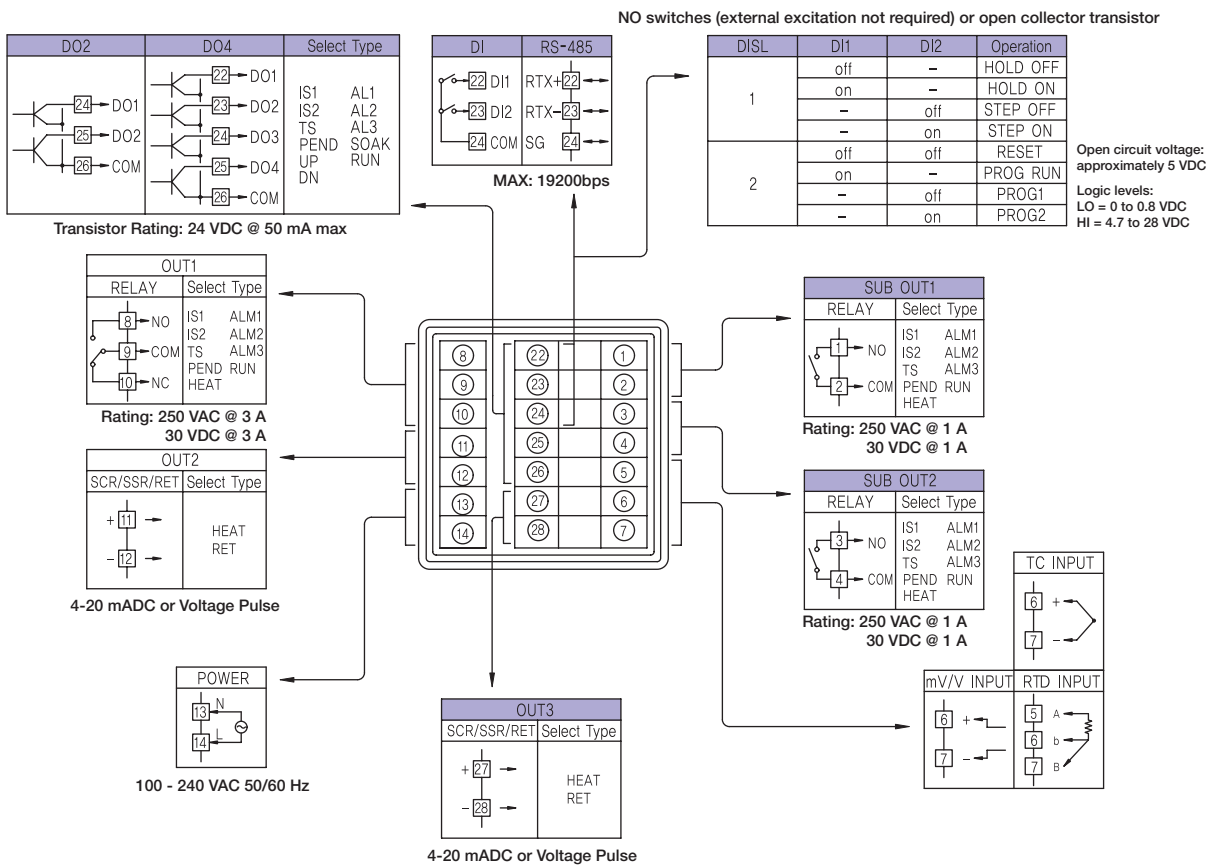

PD556

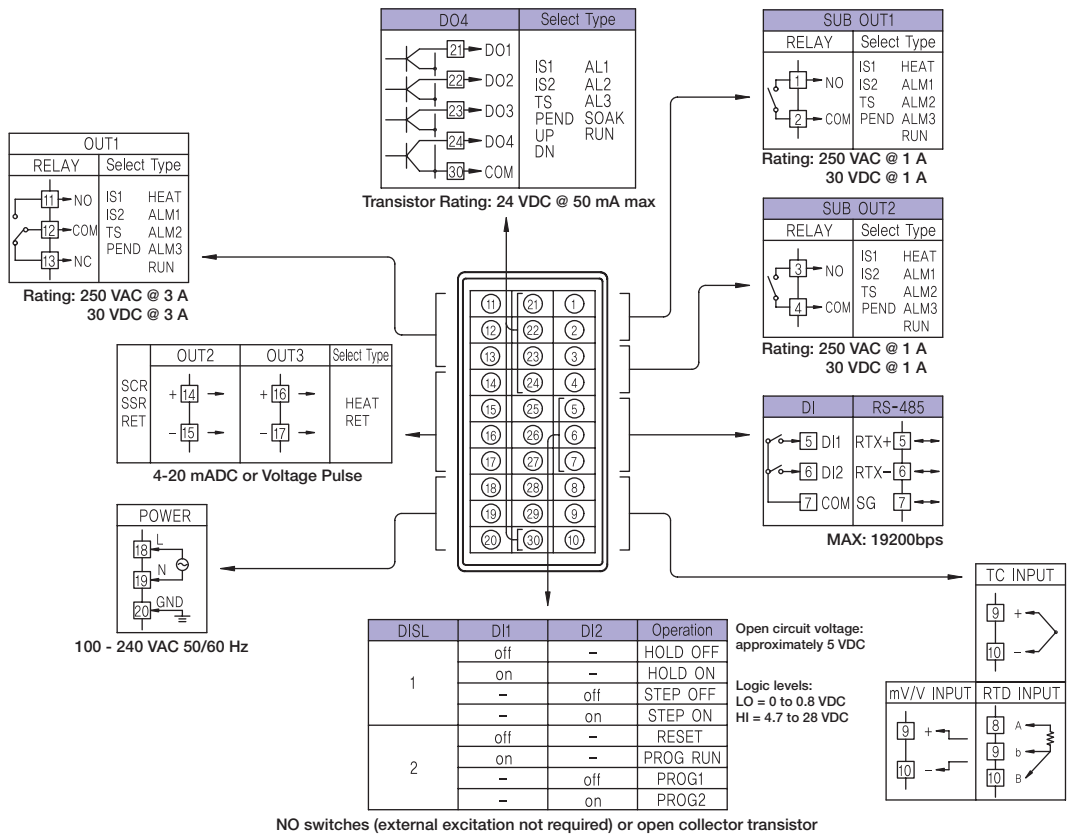

CONNECTIONS

PD558

: Options

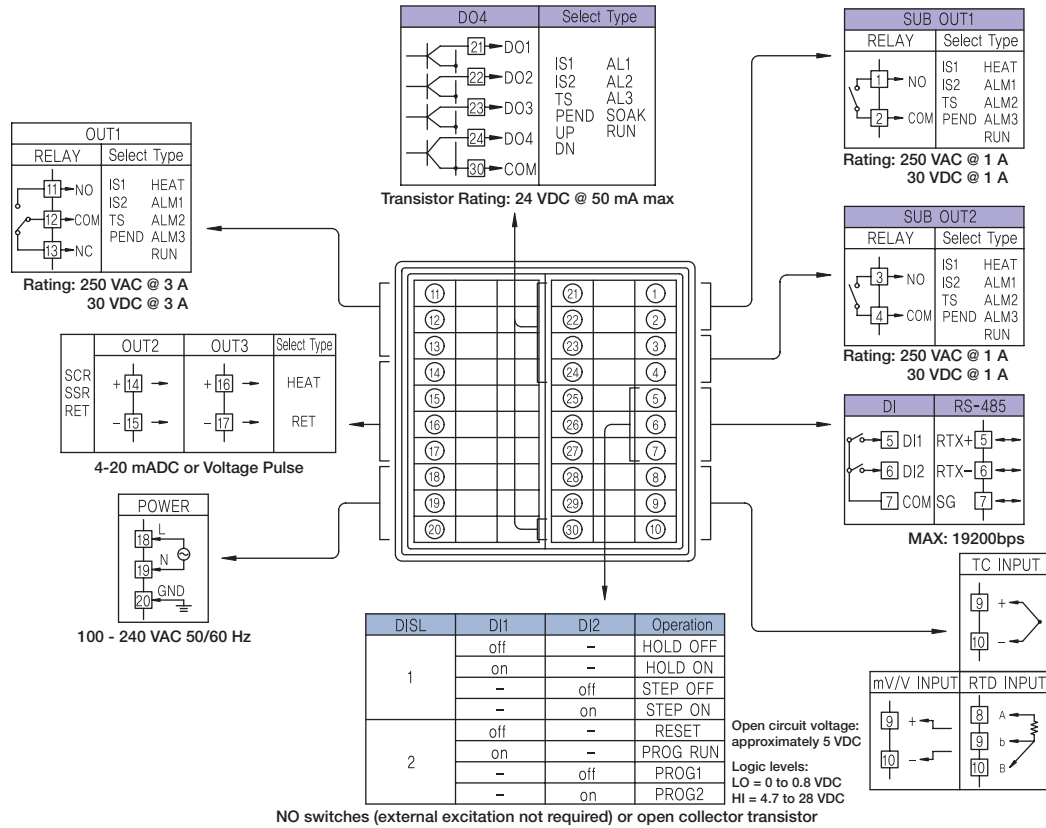

MODEL NUMBER GUIDE

The following guide describes the possible PD550 Series Nova Programmable Ramp & Soak Process & Temperature Controller model numbers. Refer to the price list for the complete list of models and accessories.

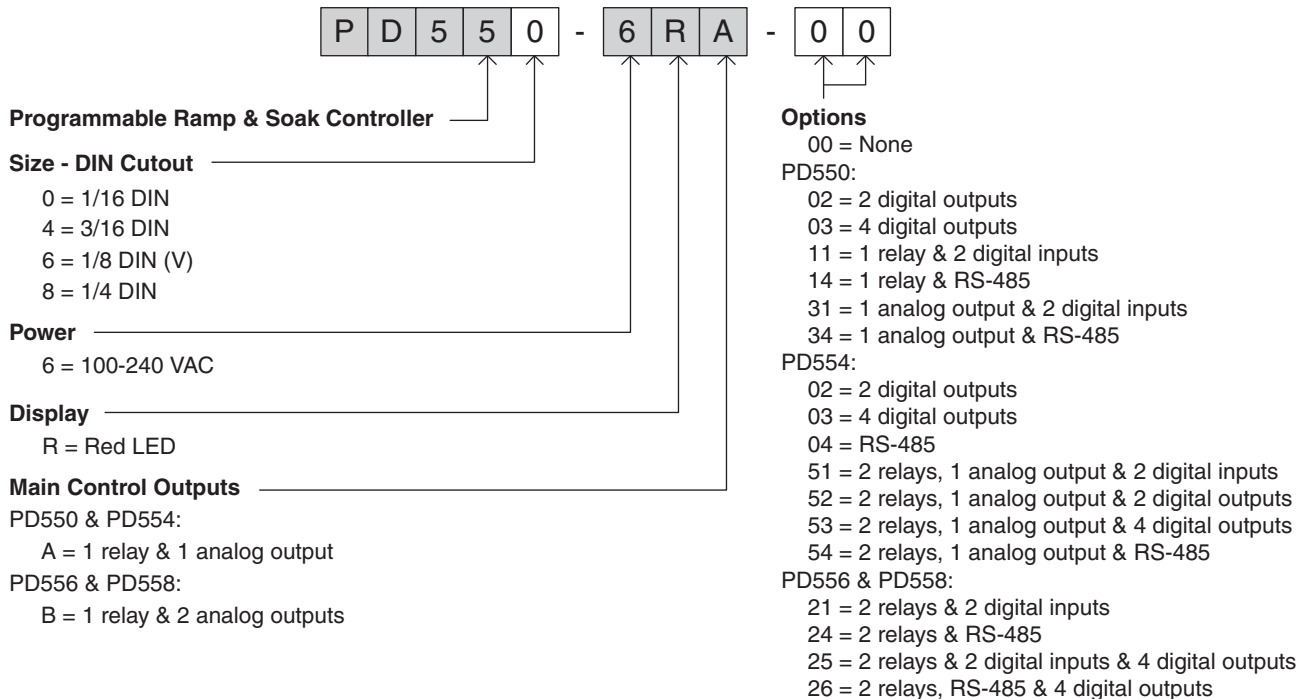

DIMENSIONS AND PANEL CUTOUTS

**Units: inches
(mm)**

PD550

1/16 DIN (48 x 48)

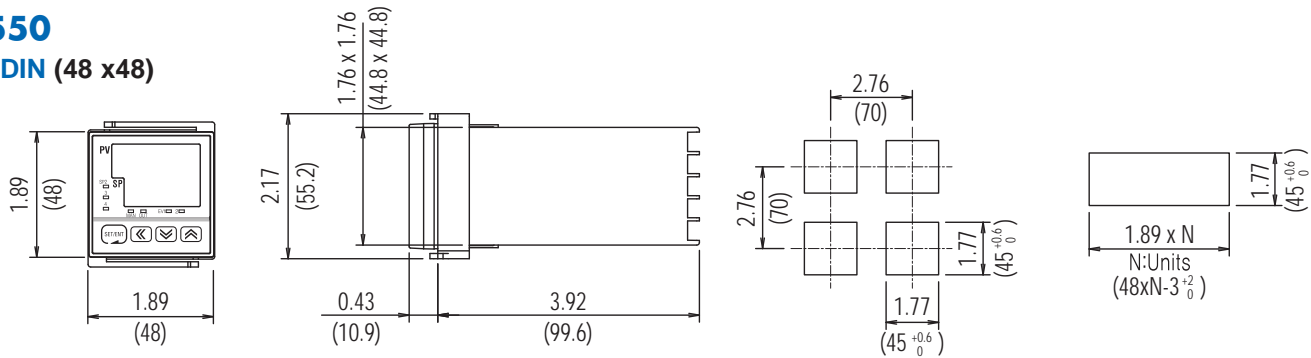

PD554

3/16 DIN (72 x 72)

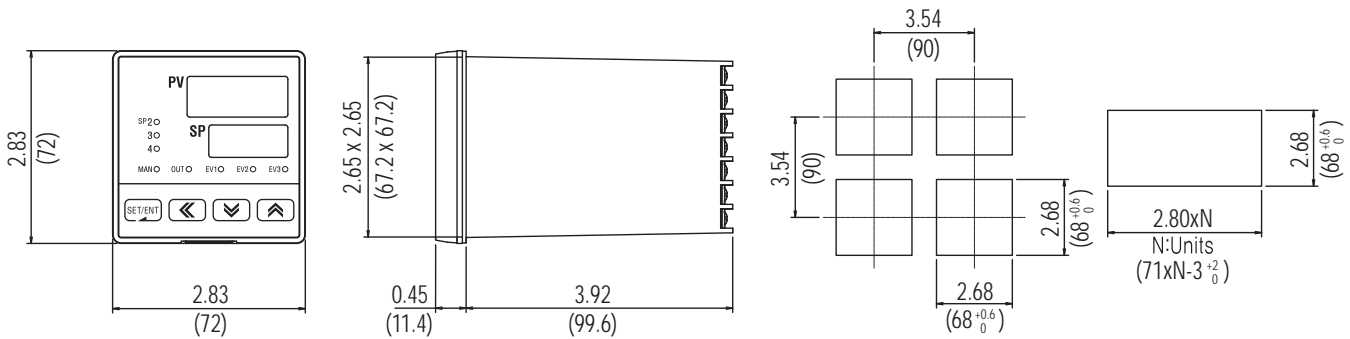

PD556

1/8 DIN (V) (48 x 96)

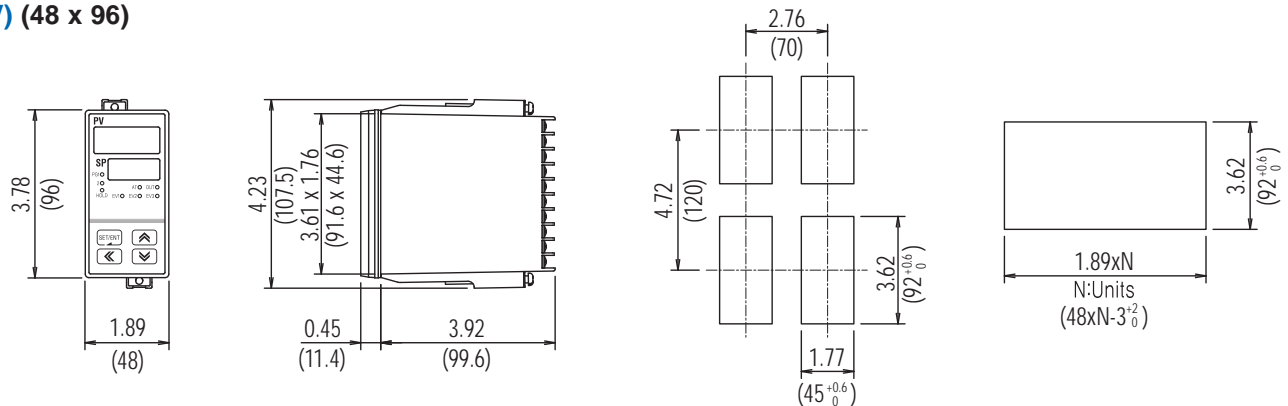

PD558

1/4 DIN (96 x 96)

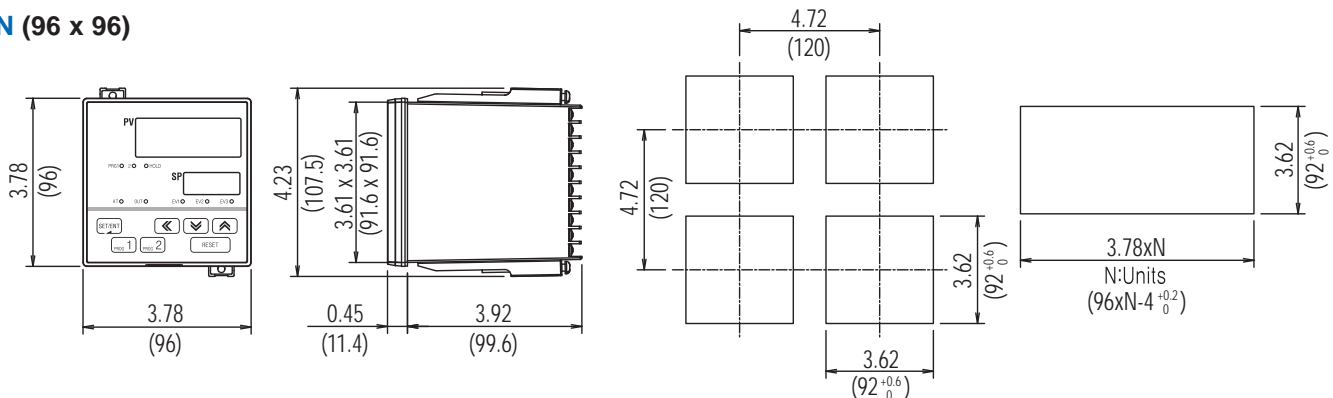

SPECIFICATIONS

Except where noted all specifications apply to operation at +25°C.

General

Display: Dual 4 digits, red LED, -1999 to 9999

DIN Sizes	PV Display Inch (mm)	SP Display Inch (mm)	Weight oz (g)
1/16	0.45 (11.3)	0.37 (9.5)	7.0 (198)
3/16	0.55 (14.0)	0.47 (12.0)	12.4 (352)
1/8 (V)	0.54 (13.6)	0.41 (10.5)	11.8 (333)
1/4	0.81 (20.5)	0.43 (11.0)	14.9 (421)

Front Panel: Panel gasket provided. 1/16 & 1/8 DIN: IP65, 3/16 & 1/4 DIN: IP55

Programming Methods: Four front panel buttons and Modbus

Ramp & Soak Programs: 2 with 15 segments each

Noise Filter: Programmable 1 to 120 seconds, or off

Display Update Rate: 4/second

Password: Restricts modification of programmed settings.

Non-Volatile Memory: Settings stored for a minimum of 10 years.

Power: 100-240 VAC, 50/60 Hz, 10 W

Required Fuse: UL Recognized, 1 A, 250 V, slow-blow

Isolation: 2300 V input/output-to-power line; 4 kV relay output-to-input/output/power line.

Operating Temperature: 10 to 50°C

Storage Temperature: -40 to 85°C

Relative Humidity: 20 to 90% non-condensing

Enclosure: 1/16, 3/16, 1/8, & 1/4 DIN available; impact-resistant plastic; color: black

UL File Number: E244207; Process Control Equipment

Approvals: UL & C-UL Recognized, CE Compliant

Warranty: 3 years parts & labor

Extended Warranty: 1 or 2 years, refer to Price List for details.

Process Inputs

Inputs: Field selectable: 0.4 to 2.0 V, 1 to 5 V, 0 to 10 V, -10 to 20 mV, 0 to 100 mV. 4-20 mA input requires 100 Ω resistor connected across input terminals (order P/N: PDX-RES1).

Accuracy: ±0.1% FS ±1 count

Decimal Point: Up to 3 decimals: 9.999, 99.99, 999.9, or 9999

Calibration: All inputs are calibrated at the factory

Scale Range: User programmable over entire range

Transmitter Supply: 14 to 18 VDC @ 20 mA; available at terminals OUT2 or OUT3, instead of retransmitting analog output; selection is made through the front panel.

Relays

Ratings: 1 Form C (SPDT) standard; rated 3 A @ 30 VDC or 3 A @ 250 VAC resistive load. 1 or 2 Form A (SPST) optional; rated 1 A @ 30 VDC or 1 A @ 250 VAC resistive load.

Relay Operation: Time proportional PID control, forward or reverse (fail-safe) alarms, inner signal PV or SP zones, program segment time signals, or program run or end alerts

Cycle Time: 1 to 300 seconds; time proportional PID control only.

High/Low Alarm: User may program any alarm for absolute high or low trigger values.

Deviation Alarm: User may program any relay for high, low, or high/low range set point deviation alarm.

Alarm Deadband: 0-100% FS, user selectable

Alarm Delay: 0 to 99 minutes and 59 seconds

Reverse Operation (Fail-Safe): Programmable, independent for each alarm.

Relay coils are energized in non-alarm condition. In case of power failure, relays will go to alarm state.

Forward Operation: Relay coils are energized in alarm condition. In case of power failure, relays will go to non-alarm state.

Inner Signal Zones (IS): Relay activates with inner signal 1 or 2 states, based on the value of the PV, SP, or target SP of the program segment. Two programmable trigger value ranges.

Time Signal (TS): Relay activates during program segments with time signals.

Program Run (RUN): Relay activates during program operation.

Program End Alert (PEND): Relay activates for 15 seconds following reset at program completion.

Auto Alarm Initialization: Normal and standby operation independent for each alarm. Normal alarms will reflect the state of the input to the controller at all times. Standby alarms will not trigger if the change to alarm state is a result of power up cycle, set point change, or alarm configuration change.

Temperature Inputs

Inputs: Factory calibrated, field selectable: J, K, T, E, B, R, S, L, U, N, W, and Platinel II thermocouples and 100 Ω platinum RTD (0.00385 or 0.00392 curve)

Cold Junction Reference: Automatic or off

Offset Adjustment: Four programmable input bias zones

Sensor Break: Up or down scale, user selectable; display reads S.OPN; alarm relays will follow the up or down scale selection.

Type	Range (°C)	Range (°F)	Accuracy*	
Thermocouple	K1	-200 to 1370	-300 to 2500	>0°C: ±0.1% FS ±1 count <0°C: ±0.2% FS ±1 count
	K2	-199.9 to 999.9	0 to 2300	
	J	-199.9 to 999.9	-300 to 2300	
	T	-199.9 to 400.0	-300 to 750	
	E	-199.9 to 999.9	-300 to 1800	
	B	0 to 1800	32 to 3300	>400°C: ±0.15% FS ±1 count <400°C: ±5% FS ±1 count
	R	0 to 1700	32 to 3100	±0.15% FS ±1 count
	S	0 to 1700	32 to 3100	±0.15% FS ±1 count
	L	-199.9 to 900.0	-300 to 1600	>0°C: ±0.1% FS ±1 count <0°C: ±0.2% FS ±1 count
	U	-199.9 to 400.0	-300 to 750	>0°C: ±0.1% FS ±1 count <0°C: ±0.25% FS ±1 count
RTD	N	-200 to 1300	-300 to 2400	±0.2% FS ±1 count
	W	0 to 2300	32 to 4200	±0.1% FS ±1 count
	Platinel II	0 to 1390	32 to 2500	±0.1% FS ±1 count
	PtA	-199.9 to 850.0	-300 to 1560	±0.1% FS ±1 count
	PtB	-199.9 to 500.0	-199.9 to 999.9	±0.2% FS ±1 count
	PtC	-19.99 to 99.99	-4.0 to 212.0	±0.1% FS ±1 count
JPtA	-199.9 to 500.0	-199.9 to 999.9	±0.1% FS ±1 count	
JPtB	-150.0 to 150.0	-199.9 to 300.0	±0.1% FS ±1 count	

*Performance within recommended operating conditions (10 to 50 °C, 20 to 90% RH)

Digital Outputs

Configuration: 2 or 4 open collector transistor

Operation Modes: Alarms, inner signal zones (IS), program segment time signals (TS), SP status (ramp up/down or soak), program running (RUN) or end alerts (PEND). See *Relays* above for operation mode details.

Transistor Rating: 24 VDC @ 50 mA

Analog Outputs

Scaling Range: Retransmitting 4-20 mA outputs can be scaled for any range.

Accuracy: ±0.1% FS

Availability: 1/16 & 3/16 DIN: 1 standard, 1 optional, 1/8 & 1/4 DIN: 2 standard

Output Operation: 4-20 mA PID control, time proportional voltage pulse PID control, or 4-20 mA retransmitting

Ratings: Continuous 4-20 mA PID or retransmitting: 600 Ω max

Time Proportional PID: 15 VDC pulse high, less than 0.1 VDC pulse low;

600 Ω minimum, current limited at 30 mA

Cycle Time: 1 to 300 seconds; time proportional PID control only

Power: Internally powered 4-20 mA output

Isolation: 500 V input-to-output

Output Loop Resistance: 600 Ω max

Digital Inputs

Configuration: Two contacts, two operating modes

Contacts: Normally open switches (external excitation not required) or open collector transistor

Open Circuit Voltage: Approximately 5 VDC

Logic Levels: LO = 0 to 0.8 VDC, HI = 4.7 to 28 VDC

Operation Modes: Mode 1: Program hold and step; Mode 2: Program run or reset.

Serial Communications

Compatibility: EIA-485

Protocols: PC, Modbus (ASCII, RTU), Sync (Master SP Control)

Address: 1 to 99 (Max 31 units connected)

Baud Rate: 600 to 19,200 bps

Data: 7 or 8 bit, automatic when using Modbus protocol

Transmit Time Delay: 0 to 100 ms

Stop Bit: 1 or 2

Parity: None, even, or odd

LDS550_D 12/15